

# SLOVENSKI STANDARD

## SIST EN 2997-003:2012

01-september-2012

Nadomešča:

SIST EN 2997-003:2009

---

**Aeronavtika - Konektorji, električni, okrogli, priključeni z navojnim obročkom, odporni ali neodporni proti ognju, s stalno delovno temperaturo med -65 °C in 175 °C, stalno 200 °C, najvišjo 260 °C - 003. del: Podlaga s kvadratno prirobnico - Standard za izdelek**

Aerospace series - Connectors, electrical, circular, coupled by threaded ring, fire-resistant or non fire-resistant, operating temperatures - 65 °C to 175 °C continuous, 200 °C continuous, 260 °C peak - Part 003: Square flange receptacle - Product standard

(standards.iteh.ai)

Luft- und Raumfahrt - Elektrische Rundsteckverbinder mit Schraubkupplung, feuerbeständig oder nicht feuerbeständig, Betriebstemperaturen - 65 °C bis 175 °C konstant, 200 °C konstant, 260 °C Spitze - Teil 003: Fester Steckverbinder mit quadratischem Montageflansch - Produktnorm

Série aérospatiale - Connecteurs électriques circulaires à accouplement par bague fileté, résistant au feu ou non, températures d'utilisation - 65 °C à 175 °C continu, 200 °C continu, 260 °C en pointe - Partie 003: Embase à fixation par collerette carrée - Norme de produit

**Ta slovenski standard je istoveten z: EN 2997-003:2012**

---

**ICS:**

49.060	Letalska in vesoljska električna oprema in sistemi	Aerospace electric equipment and systems
--------	--	--

**SIST EN 2997-003:2012**

**en**

**iTeh STANDARD PREVIEW**  
**(standards.iteh.ai)**

SIST EN 2997-003:2012

<https://standards.iteh.ai/catalog/standards/sist/7d4093c8-f67b-4a50-bb65-aa468eabc229/sist-en-2997-003-2012>

EUROPEAN STANDARD

EN 2997-003

NORME EUROPÉENNE

EUROPÄISCHE NORM

May 2012

ICS 49.060

Supersedes EN 2997-003:2006

English Version

Aerospace series - Connectors, electrical, circular, coupled by threaded ring, fire-resistant or non fire-resistant, operating temperatures - 65 °C to 175 °C continuous, 200 °C continuous, 260 °C peak - Part 003: Square flange receptacle - Product standard

Série aérospatiale - Connecteurs électriques circulaires à accouplement par bague fileté, résistant au feu ou non, températures d'utilisation - 65 °C à 175 °C continu, 200 °C continu, 260 °C en pointe - Partie 003: Embase à fixation par collerette carrée - Norme de produit

Luft- und Raumfahrt - Elektrische Rundsteckverbinder mit Schraubkupplung, feuerbeständig oder nicht feuerbeständig, Betriebstemperaturen - 65 °C bis 175 °C konstant, 200 °C konstant, 260 °C Spitze - Teil 003: Fester Steckverbinder mit quadratischem Montageflansch - Produktnorm

**iTeh STANDARD PREVIEW**

This European Standard was approved by CEN on 11 February 2012.

CEN members are bound to comply with the CEN/CENELEC Internal Regulations which stipulate the conditions for giving this European Standard the status of a national standard without any alteration. Up-to-date lists and bibliographical references concerning such national standards may be obtained on application to the CEN-CENELEC Management Centre or to any CEN member.

This European Standard exists in three official versions (English, French, German). A version in any other language made by translation under the responsibility of a CEN member into its own language and notified to the CEN-CENELEC Management Centre has the same status as the official versions.

CEN members are the national standards bodies of Austria, Belgium, Bulgaria, Croatia, Cyprus, Czech Republic, Denmark, Estonia, Finland, France, Germany, Greece, Hungary, Iceland, Ireland, Italy, Latvia, Lithuania, Luxembourg, Malta, Netherlands, Norway, Poland, Portugal, Romania, Slovakia, Slovenia, Spain, Sweden, Switzerland, Turkey and United Kingdom.



EUROPEAN COMMITTEE FOR STANDARDIZATION  
COMITÉ EUROPÉEN DE NORMALISATION  
EUROPÄISCHES KOMITEE FÜR NORMUNG

Management Centre: Avenue Marnix 17, B-1000 Brussels

**Contents**

Page

Foreword.....	3
1 <b>Scope</b> .....	4
2 <b>Normative references</b> .....	4
3 <b>Terms and definitions</b> .....	4
4 <b>Required characteristics</b> .....	5
5 <b>Designation</b> .....	8
6 <b>Marking</b> .....	9
7 <b>Technical specification</b> .....	9

**iTeh STANDARD PREVIEW**  
**(standards.iteh.ai)**

[SIST EN 2997-003:2012](https://standards.iteh.ai/catalog/standards/sist/7d4093c8-f67b-4a50-bb65-aa468eabc229/sist-en-2997-003-2012)

<https://standards.iteh.ai/catalog/standards/sist/7d4093c8-f67b-4a50-bb65-aa468eabc229/sist-en-2997-003-2012>

## Foreword

This document (EN 2997-003:2012) has been prepared by the Aerospace and Defence Industries Association of Europe - Standardization (ASD-STAN).

After enquiries and votes carried out in accordance with the rules of this Association, this Standard has received the approval of the National Associations and the Official Services of the member countries of ASD, prior to its presentation to CEN.

This European Standard shall be given the status of a national standard, either by publication of an identical text or by endorsement, at the latest by November 2012, and conflicting national standards shall be withdrawn at the latest by November 2012.

Attention is drawn to the possibility that some of the elements of this document may be the subject of patent rights. CEN [and/or CENELEC] shall not be held responsible for identifying any or all such patent rights.

This document supersedes EN 2997-003:2006.

According to the CEN/CENELEC Internal Regulations, the national standards organizations of the following countries are bound to implement this European Standard: Austria, Belgium, Bulgaria, Croatia, Cyprus, Czech Republic, Denmark, Estonia, Finland, France, Germany, Greece, Hungary, Iceland, Ireland, Italy, Latvia, Lithuania, Luxembourg, Malta, Netherlands, Norway, Poland, Portugal, Romania, Slovakia, Slovenia, Spain, Sweden, Switzerland, Turkey and the United Kingdom.

[SIST EN 2997-003:2012](https://standards.iteh.ai/catalog/standards/sist/7d4093c8-f67b-4a50-bb65-aa468eabc229/sist-en-2997-003-2012)

<https://standards.iteh.ai/catalog/standards/sist/7d4093c8-f67b-4a50-bb65-aa468eabc229/sist-en-2997-003-2012>

**EN 2997-003:2012 (E)****1 Scope**

This European Standard specifies the characteristics of square flange mounted receptacles in the family of circular electrical connectors coupled by threaded ring.

It applies to class defined in Table 3.

For contacts, sealing plugs and rear associated cable outlets with this receptacle, see EN 2997-002. For plugs and protective covers, see EN 2997-008 and EN 2997-009 respectively.

**2 Normative references**

The following documents, in whole or in part, are normatively referenced in this document and are indispensable for its application. For dated references, only the edition cited applies. For undated references, the latest edition of the referenced document (including any amendments) applies.

EN 2997-001, *Aerospace series — Connectors, electrical, circular, coupled by threaded ring, fire-resistant or non fire-resistant, operating temperatures – 65 °C to 175 °C continuous, 200 °C continuous, 260 °C peak — Part 001: Technical specification*

EN 2997-002, *Aerospace series — Connectors, electrical, circular, coupled by threaded ring, fire-resistant or non fire-resistant, operating temperatures – 65 °C to 175 °C continuous, 200 °C continuous, 260 °C peak — Part 002: Specification of performance and contact arrangements*

EN 2997-008, *Aerospace series — Connectors, electrical, circular, coupled by threaded ring, fire-resistant or non fire-resistant, operating temperatures – 65 °C to 175 °C continuous, 200 °C continuous, 260 °C peak — Part 008: Plug — Product standard*

EN 2997-009, *Aerospace series — Connectors, electrical, circular, coupled by threaded ring, fire-resistant or non fire-resistant, operating temperatures – 65 °C to 175 °C continuous, 200 °C continuous, 260 °C peak — Part 009: Protective cover for receptacle — Product standard*

EN 3155-002, *Aerospace series — Electrical contacts used in elements of connection — Part 002: List and utilization of contacts*

**3 Terms and definitions**

For the purposes of this standard, the terms and definitions given in EN 2997-001 apply.

## 4 Required characteristics

### 4.1 Dimensions and mass

See Figure 1 and Table 1.

Dimensions and tolerances are in millimetres; they apply after surface treatment.

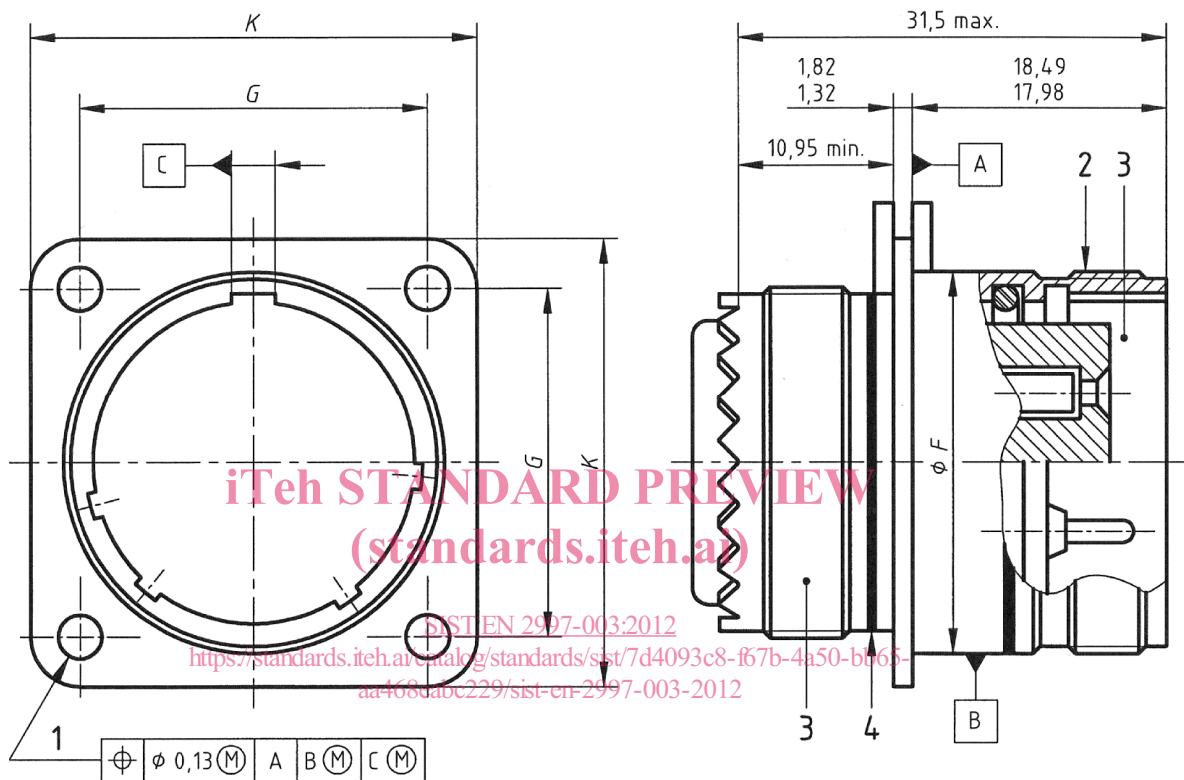

Figure 1

Table 1

Housing size	<i>F</i> max.	<i>G</i>	<i>K</i>		Mass <sup>a</sup> g max.	
			max.	min.	Stainless steel	Aluminium alloy
08	14,27	15,09	20,75	20,49	19	11
10	17,67	18,26	23,93	23,67	28	16
12	22,22	20,62	26,32	26,06	39	27
14	23,77	23,01	28,71	28,45	51	30
16	26,97	24,61	31,88	31,62	62	34
18	30,15	26,97	34,24	33,98	73	36
20	33,32	29,36	36,63	36,37	82	40
22	36,49	31,75	39,80	39,54	90	51
24	39,67	34,92	43,39	43,13	105	58
28	46,02	39,67	50,93	50,67	126	88

<sup>a</sup> Mass without accessory and without contacts.

**ITeH STANDARD PREVIEW**  
(standards.iteh.ai)

SIST EN 2997-003:2012

<https://standards.iteh.ai/catalog/standards/sist/7d4093c8-f67b-4a50-bb65-aa468eabc229/sist-en-2997-003-2012>



## 4.2 Panel cut-out and mounting of connectors

See Figure 2 and Table 2 for panel cut-out and Figure 3 for mounting of connectors.

Dimensions and tolerances are in millimetres.

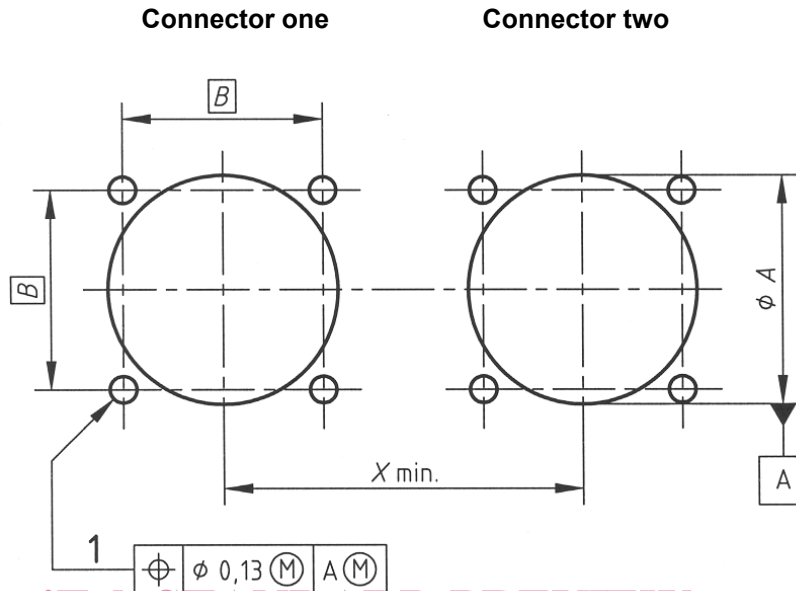

iTeh STANDARD PREVIEW  
(standards.iteh.ai)

### Key

1 four holes  $\phi C$

SIST EN 2997-003:2012

$X \text{ min.}$  value is calculated as follows:  $D/2$  connector one +  $D/2$  connector two (See Table 2 for value  $D$ )

aa468eabc229/sist-en-2997-003-2012

**Figure 2**

**Table 2**

Housing size	$A$ min.	$B$	$C$	$D$ min.
08	15,80	15,09	3,30 3,10	31,70
10	18,70	18,26		34,90
12	23,40	20,62		39,60
14	24,90	23,01		41,25
16	28,30	24,61		44,45
18	31,10	26,97		47,35
20	34,50	29,36		51,90
22	37,50	31,75		54,10
24	40,60	34,92	3,91 3,68	57,25
28	48,00	39,67		65,25