Methods of test for refractory products —
Part 1:
Determination of dynamic Young's
modulus (MOE) by impulse excitation of
vibration

Méthodes d'essai pour produits réfractaires —

Partie 1: Détermination du module de Young dynamique (MOE) par
excitation de vibration par impulsion

[ISO 12680-1:2005](https://standards.iso.org/iso/12680-1:2005)

[https://standards.iteh.ai/catalog/standards/sist/3bb6ab87-1ce3-4d21-883b-
fe93996ed755/iso-12680-1-2005](https://standards.iteh.ai/catalog/standards/sist/3bb6ab87-1ce3-4d21-883b-fe93996ed755/iso-12680-1-2005)



PDF disclaimer

This PDF file may contain embedded typefaces. In accordance with Adobe's licensing policy, this file may be printed or viewed but shall not be edited unless the typefaces which are embedded are licensed to and installed on the computer performing the editing. In downloading this file, parties accept therein the responsibility of not infringing Adobe's licensing policy. The ISO Central Secretariat accepts no liability in this area.

Adobe is a trademark of Adobe Systems Incorporated.

Details of the software products used to create this PDF file can be found in the General Info relative to the file; the PDF-creation parameters were optimized for printing. Every care has been taken to ensure that the file is suitable for use by ISO member bodies. In the unlikely event that a problem relating to it is found, please inform the Central Secretariat at the address given below.

iTeh STANDARD PREVIEW
(standards.iteh.ai)

[ISO 12680-1:2005](https://standards.iteh.ai/catalog/standards/sist/3bb6ab87-1ce3-4d21-883b-fe93996ed755/iso-12680-1-2005)

<https://standards.iteh.ai/catalog/standards/sist/3bb6ab87-1ce3-4d21-883b-fe93996ed755/iso-12680-1-2005>

© ISO 2005

All rights reserved. Unless otherwise specified, no part of this publication may be reproduced or utilized in any form or by any means, electronic or mechanical, including photocopying and microfilm, without permission in writing from either ISO at the address below or ISO's member body in the country of the requester.

ISO copyright office
Case postale 56 • CH-1211 Geneva 20
Tel. + 41 22 749 01 11
Fax + 41 22 749 09 47
E-mail copyright@iso.org
Web www.iso.org

Published in Switzerland

Contents

Page

Foreword.....	iv
1 Scope	1
2 Normative references	1
3 Terms and definitions.....	1
4 Principle.....	2
5 Significance and use	3
6 Apparatus	3
7 Sampling.....	5
8 Test specimens	5
9 Procedure	5
10 Calculations.....	7
11 Test report	10
Annex A (informative) Factors affecting accuracy of determinations	11

ITeH STANDARD PREVIEW
(standards.iteh.ai)

[ISO 12680-1:2005](https://standards.iteh.ai/catalog/standards/sist/3bb6ab87-1ce3-4d21-883b-fe93996ed755/iso-12680-1-2005)

<https://standards.iteh.ai/catalog/standards/sist/3bb6ab87-1ce3-4d21-883b-fe93996ed755/iso-12680-1-2005>

Foreword

ISO (the International Organization for Standardization) is a worldwide federation of national standards bodies (ISO member bodies). The work of preparing International Standards is normally carried out through ISO technical committees. Each member body interested in a subject for which a technical committee has been established has the right to be represented on that committee. International organizations, governmental and non-governmental, in liaison with ISO, also take part in the work. ISO collaborates closely with the International Electrotechnical Commission (IEC) on all matters of electrotechnical standardization.

International Standards are drafted in accordance with the rules given in the ISO/IEC Directives, Part 2.

The main task of technical committees is to prepare International Standards. Draft International Standards adopted by the technical committees are circulated to the member bodies for voting. Publication as an International Standard requires approval by at least 75 % of the member bodies casting a vote.

Attention is drawn to the possibility that some of the elements of this document may be the subject of patent rights. ISO shall not be held responsible for identifying any or all such patent rights.

ISO 12680-1 was prepared by Technical Committee ISO/TC 33, *Refractories*.

ISO 12680 consists of the following parts, under the general title *Methods of test for refractory products*:

— *Part 1: Determination of dynamic Young's modulus (MOE) by impulse excitation of vibration*

The following part is under preparation:

— *Part 2: Determination of static modulus of elasticity*

[ISO 12680-1:2005](https://standards.iteh.ai/catalog/standards/sist/3bb6ab87-1ce3-4d21-883b-1e93996cd755/iso-12680-1-2005)

<https://standards.iteh.ai/catalog/standards/sist/3bb6ab87-1ce3-4d21-883b-1e93996cd755/iso-12680-1-2005>

Methods of test for refractory products —

Part 1:

Determination of dynamic Young's modulus (MOE) by impulse excitation of vibration

1 Scope

This part of ISO 12680 specifies a method for determining the dynamic Young's modulus of rectangular cross-section bars and circular cross-section specimens of refractories by impulse excitation of vibration. The dynamic Young's modulus is determined using the resonant frequency of the specimen in its flexural mode of vibration.

NOTE Although not specifically described in this part of ISO 12680, this method can also be used at high temperatures with suitable equipment modification.

This part of ISO 12680 does not address the safety issues associated with its use. It is the responsibility of the users of this standard to establish appropriate safety and health practices.

2 Normative references

The following referenced documents are indispensable for the application of this document. For dated references, only the edition cited applies. For undated references, the latest edition of the referenced document (including any amendments) applies.

ISO 5022:1979, *Shaped refractory products — Sampling and acceptance testing*

ISO 8656-1:1988, *Refractory products — Sampling of raw materials and unshaped products — Part 1: Sampling scheme*

3 Terms and definitions

For the purposes of this document, the following terms and definitions apply.

3.1

modulus of elasticity

MOE

ratio of stress to strain below the proportional limit

3.2

proportional limit

greatest stress which a material is capable of sustaining without deviation from proportionality of stress to strain (Hooke's Law)

3.3

anti-nodes

locations, generally two or more, of local maximum displacement in an unconstrained slender bar or rod in resonance

NOTE For the fundamental flexural resonance, the anti-nodes are located at the two ends and the centre of the specimen.

3.4

flexural vibrations

displacements in a slender rod or bar in the plane normal to its length

3.5

homogeneous

uniform composition, density and texture

NOTE A result of homogeneity is that any smaller specimen taken from the original is representative of the whole. In refractory practice, as long as the geometrical dimensions of the specimen are large with respect to the size of individual grains, crystals, components, pores and microcracks, the body can be considered homogeneous.

3.6

in-plane flexure, noun

flexural mode for rectangular parallelepiped geometry specimens in which the direction of the displacement is in the major plane of the specimen

3.7

isotropic, adj.

condition of a specimen such that the values of the elastic properties are the same in all directions in the specimen

3.8

nodes

location on a slender rod or bar in resonance having a constant zero displacement

NOTE For the fundamental flexural resonance of such a rod or bar, the nodes are located at $0,224 L$ from each end, where L is the length of the specimen.

3.9

out-of-plane flexure

flexural mode for rectangular parallelepiped geometry specimens in which the direction of the displacement is perpendicular to the major plane of the specimen

3.10

resonant frequency

natural frequencies of vibration of a body driven into flexural vibration

NOTE Resonant frequencies are determined by the elastic modulus, mass and dimensions of the specimen. The lowest resonant frequency in a vibrational mode is the fundamental resonant frequency of that mode.

3.11

slender rod

slender bar

specimen whose ratio of length to minimum cross-section thickness or diameter is at least 5

NOTE This applies to dynamic elastic property testing.

4 Principle

A test specimen of suitable geometry is excited mechanically with a single elastic strike of an impulse tool, called a hammer, and its fundamental resonant frequency is determined.

A transducer (e.g. contact accelerometer or non-contacting microphone) senses the mechanical vibrations in the specimen resulting from the excitation and transforms the vibrations into electrical signals. Specimen supports, impulse locations and signal pick-up points are selected to induce and measure a specific mode of transient vibrations, i.e. the flexural mode. The signals are analysed and a signal analyser that provides data about the frequency and/or the period of the specimen's vibration determines the fundamental resonant frequency. The appropriate fundamental resonant frequency, dimensions and mass of the specimen are used to calculate the dynamic Young's modulus.

5 Significance and use

This test method may be used for refractory characterization, development and quality control purposes.

This test method is appropriate for determining the modulus of elasticity of refractory bodies that are homogeneous in nature.

This method addresses the determination of the dynamic moduli of elasticity of slender rectangular bars and cylindrical rods.

This test method is non-destructive in use so it may be used on specimens prepared for other tests. The specimens are subjected to only minute strains; hence the moduli are measured at or near the origin of the stress-strain curve with a minimum possibility of specimen fracture.

The test provides options for variations in test specimen sizes and procedure to accommodate most refractory compositions and textures.

The impulse excitation test method utilizes an impact tool (hammer) and simple supports for the test specimen.

This test method is not suitable for specimens with major cracks or voids.

This test method is limited to determining moduli of specimens with regular geometries, such as rectangular parallelepipeds and cylinders, for which analytical equations are available to relate geometry, mass and modulus to the resonant vibration frequency.

The analytical equations assume parallel or concentric dimensions for the geometry of the specimens. Deviations in the dimensions of the specimens will introduce errors in the calculations and in the results of the tests.

Uneven or excessively rough surfaces of as-formed specimens can have a significant effect on the accuracy of the determination. The dynamic modulus value is inversely proportional to the cube of the thickness so the thickness variation is significant.

This test method assumes that the specimen is vibrating freely with no significant restraint or impediment. Specimen supports should be designed and located so the specimen can vibrate freely in the proper mode.

6 Apparatus

6.1 Excitation apparatus

This apparatus is used to excite vibrations in the test specimens and then accurately detect, analyse and measure the fundamental resonant frequency or period of a vibrating beam. Figure 1 shows a block diagram of such an apparatus. It consists of a small hammer, a suitable pickup transducer to convert the mechanical vibrations into electrical signals, an electronic signal analyser system consisting of a signal conditioner/amplifier, a signal analyser and a frequency read-out device ¹⁾.

1) An example of a suitable instrument is the Grindosonic instrument, manufactured by J.W. Lemmens, Inc., 3466 Bridgeland Drive, Suite 230, St. Louis MO, 63044-2602 USA. This information is given for the convenience of users of this part of ISO 12680 and does not constitute an endorsement by ISO of this equipment.

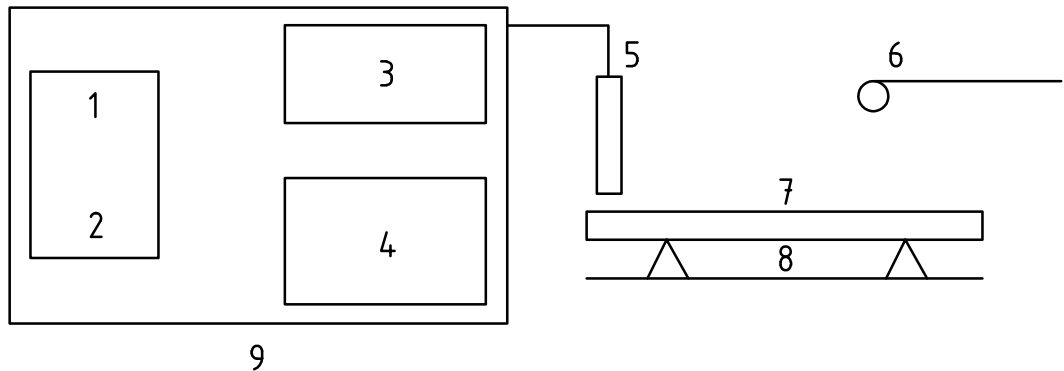

- Key**
- | | | |
|---|----------------------|---------------------|
| 1 numerical display of the measured frequency | 4 frequency analyser | 7 test specimen |
| 2 read-out device | 5 transducer | 8 support system |
| 3 signal amplifier | 6 impulser | 9 electrical system |

Figure 1 — Block diagram of typical test apparatus

6.2 Striker hammer

The hammer shall have a mass sufficient to induce a measurable mechanical vibration in the test specimen but shall be not large enough to physically displace or damage the test specimen. A typical small hammer is shown in Figure 2. Larger specimens may require larger striker hammers.

NOTE The size of the striker hammer depends on the size and physical properties of the specimens to be tested.

STANDARD PREVIEW
(standards.iteh.ai)

ISO 12680-1:2005
<https://standards.iteh.ai/catalog/standards/sist/3bb6ab87-1ce3-4d21-883b-fe93996ed755/iso-12680-1-2005>

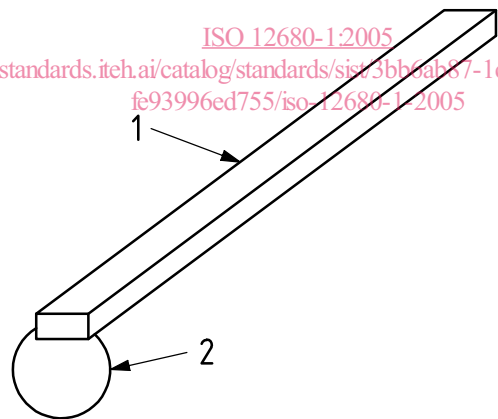

- Key**
- | |
|----------------------------------|
| 1 flexible polymer rod |
| 2 steel or other hard metal ball |

Figure 2 — Typical design for striker hammer

6.3 Signal pickup

The excited vibrational signals in the test specimens are detected by transducers in direct contact with the specimen or by non-contact transducers. Common contact transducers are accelerometers using piezoelectric or strain gauge devices to measure vibration. A common non-contact transducer is an acoustic microphone, but laser, magnetic or capacitance methods may be used as well. The frequency range of the transducer shall be sufficient to measure the expected frequencies of the test specimens. A suitable range is 50 Hz to 20 kHz for many refractory test specimens. Smaller and stiffer specimens vibrate at higher frequencies. The frequency response of the transducer across the frequency range of interest shall have a bandwidth of at least 10 % of the maximum measured frequency before -3 dB power loss occurs.

6.4 Electronic signal analysis system

The system consists of a signal conditioner/amplifier, signal analyser and frequency read-out device. The system shall have sufficient accuracy and precision to measure the test specimen's frequencies to an accuracy of 0,1 %. The signal conditioner/amplifier shall be suitable to power the transducer and to provide an appropriate amplified signal to the signal analyser. The signal analyser consists of a frequency counting device and a read-out device. Appropriate devices are frequency counter systems with storage capacity or digital storage oscilloscopes with frequency counter modules. With the digital storage oscilloscopes, a Fast Fourier Transform signal analysis system may be useful for analysing more complex waveforms and identifying the fundamental resonant frequency of the test specimen.

6.5 Specimen support

The specimen supports serve to isolate the specimens from extraneous vibrations without restricting the desired mode of vibration of the specimens. The support materials shall be stable at the test temperature. For ambient conditions, support materials may be either soft or rigid. Examples of soft materials are compliant elastomerics such as polyurethane foam strips. Specimens should be supported on flat surfaces of these foam strips. Rigid material supports, such as metal or ceramic, shall have sharp knife edges or cylindrical surfaces for the test specimens to rest on. The rigid supports, in turn, shall rest on isolation pads to prevent the pick-up of spurious vibrations by the specimen and then the transducer. Wire suspension specimen support systems may also be used. Support the specimens at the nodes located at 0,224 L of the total length measured from each end of the specimen (see 9.4.1).

7 Sampling

The number of specimens to be tested shall be determined in accordance with ISO 5022 for shaped products or ISO 8656-1 for unshaped products, or using a sampling plan agreed upon between the interested parties.

8 Test specimens

ISO 12680-1:2005

<https://standards.iteh.ai/catalog/standards/sist/3bb6ab87-1ce3-4d21-883b-fe93996ced755/iso-12680-1-2005>

8.1 Specimen geometry

The specimens shall be simple beams or slender rods, either rectangular or circular in cross section. A minimum ratio of 3 for the length to cross-section thickness or diameter shall be used.

8.2 Specimen dimensions

Resonant frequencies of specimens are a function of the specimens' dimensions as well as their masses and moduli of elasticity. Using an estimated modulus, specimen size shall be chosen so that the expected resonant frequencies fall within the frequency response range of the transducers and the signal analysis system to be used. The smallest dimension of the specimen shall be at least 4 times the largest grain or particle size.

8.3 Surface finishing of specimens

All surfaces of a rectangular specimen shall be flat and sufficiently parallel so that opposite faces across the length, width and thickness dimensions are parallel to within 1 %. The diameter of a cylindrical specimen shall vary by no more than 1 %.

9 Procedure

9.1 Determination of specimen mass

Determine the mass of specimens to a precision of 0,2 %.

Determine the specimen length, width and thickness to a precision of 0,2 %.