

---

---

**Glass containers — Vacuum lug  
finishes —**

**Part 6:  
53 and 58 regular**

*Réipients en verre — Bagues à crans pour bouchage sous vide —  
Partie 6: 53 et 58 regular*  
**(standards.iteh.ai)**

ISO 9100-6:2005

<https://standards.iteh.ai/catalog/standards/sist/f59a41ec-99d5-4241-9850-18bb4475cfe2/iso-9100-6-2005>



**PDF disclaimer**

This PDF file may contain embedded typefaces. In accordance with Adobe's licensing policy, this file may be printed or viewed but shall not be edited unless the typefaces which are embedded are licensed to and installed on the computer performing the editing. In downloading this file, parties accept therein the responsibility of not infringing Adobe's licensing policy. The ISO Central Secretariat accepts no liability in this area.

Adobe is a trademark of Adobe Systems Incorporated.

Details of the software products used to create this PDF file can be found in the General Info relative to the file; the PDF-creation parameters were optimized for printing. Every care has been taken to ensure that the file is suitable for use by ISO member bodies. In the unlikely event that a problem relating to it is found, please inform the Central Secretariat at the address given below.

**iTeh STANDARD PREVIEW**  
**(standards.iteh.ai)**

ISO 9100-6:2005

<https://standards.iteh.ai/catalog/standards/sist/f59a41ec-99d5-4241-9850-18bb4475cfe2/iso-9100-6-2005>

© ISO 2005

All rights reserved. Unless otherwise specified, no part of this publication may be reproduced or utilized in any form or by any means, electronic or mechanical, including photocopying and microfilm, without permission in writing from either ISO at the address below or ISO's member body in the country of the requester.

ISO copyright office  
Case postale 56 • CH-1211 Geneva 20  
Tel. + 41 22 749 01 11  
Fax + 41 22 749 09 47  
E-mail [copyright@iso.org](mailto:copyright@iso.org)  
Web [www.iso.org](http://www.iso.org)

Published in Switzerland

## Foreword

ISO (the International Organization for Standardization) is a worldwide federation of national standards bodies (ISO member bodies). The work of preparing International Standards is normally carried out through ISO technical committees. Each member body interested in a subject for which a technical committee has been established has the right to be represented on that committee. International organizations, governmental and non-governmental, in liaison with ISO, also take part in the work. ISO collaborates closely with the International Electrotechnical Commission (IEC) on all matters of electrotechnical standardization.

International Standards are drafted in accordance with the rules given in the ISO/IEC Directives, Part 2.

The main task of technical committees is to prepare International Standards. Draft International Standards adopted by the technical committees are circulated to the member bodies for voting. Publication as an International Standard requires approval by at least 75 % of the member bodies casting a vote.

Attention is drawn to the possibility that some of the elements of this document may be the subject of patent rights. ISO shall not be held responsible for identifying any or all such patent rights.

ISO 9100-6 was prepared by the European Committee for Standardization (CEN) in collaboration with Technical Committee ISO/TC 63, *Glass containers*, in accordance with the Agreement on technical cooperation between ISO and CEN (Vienna Agreement).

This first edition cancels and replaces ISO 9100:1992.

ISO 9100 consists of the following parts, under the general title *Glass containers — Vacuum lug finishes*:

- ISO 9100-6:2005
- *Part 1: General* <https://standards.iteh.ai/catalog/standards/sist/f59a41ec-99d5-4241-9850-18bb4475cfe2/iso-9100-6-2005>
  - *Part 2: 33 medium*
  - *Part 3: 38 regular*
  - *Part 4: 38 medium*
  - *Part 5: 43 and 48 regular*
  - *Part 6: 53 and 58 regular*
  - *Part 7: 58 deep*
  - *Part 8: 63, 66 and 70 regular*
  - *Part 9: 63, 66 and 70 deep*
  - *Part 10: 77 regular*
  - *Part 11: 82 regular*
  - *Part 12: 89 regular*
  - *Part 13: 100 regular*
  - *Part 14: 110 regular*

## Contents

	Page
Foreword.....	v
1 Scope .....	1
2 Normative references .....	1
3 Dimensions.....	1
Bibliography .....	5

## iTeh STANDARD PREVIEW (standards.iteh.ai)

ISO 9100-6:2005

<https://standards.iteh.ai/catalog/standards/sist/f59a41ec-99d5-4241-9850-18bb4475cfe2/iso-9100-6-2005>

## Foreword

This document (EN ISO 9100-6:2005) has been prepared by Technical Committee CEN/TC 261 "Packaging", the secretariat of which is held by AFNOR, in collaboration with Technical Committee ISO/TC 63 "Glass containers".

This European Standard shall be given the status of a national standard, either by publication of an identical text or by endorsement, at the latest by July 2005, and conflicting national standards shall be withdrawn at the latest by July 2005.

Efficient packaging is of great importance for the distribution and the protection of goods. Insufficient or inappropriate packaging can lead to damage or wastage of the contents of the pack.

It is based on CE.T.I.E (International Technical Centre for Bottling and Packaging) <sup>1)</sup> data sheet GME 20-04 : 1995.

According to the CEN/CENELEC Internal Regulations, the national standards organizations of the following countries are bound to implement this European Standard: Austria, Belgium, Cyprus, Czech Republic, Denmark, Estonia, Finland, France, Germany, Greece, Hungary, Iceland, Ireland, Italy, Latvia, Lithuania, Luxembourg, Malta, Netherlands, Norway, Poland, Portugal, Slovakia, Slovenia, Spain, Sweden, Switzerland and United Kingdom.

**iTeh STANDARD PREVIEW**  
**(standards.iteh.ai)**

[ISO 9100-6:2005](https://standards.iteh.ai/catalog/standards/sist/f59a41ec-99d5-4241-9850-18bb4475cfe2/iso-9100-6-2005)

<https://standards.iteh.ai/catalog/standards/sist/f59a41ec-99d5-4241-9850-18bb4475cfe2/iso-9100-6-2005>

---

1) Centre Technique International de l'Emboutillage (CETIE), 3, rue La Boétie, 75008 Paris, France, [www.cetie.org](http://www.cetie.org)

**iTeh STANDARD PREVIEW**  
**(standards.iteh.ai)**

ISO 9100-6:2005

<https://standards.iteh.ai/catalog/standards/sist/f59a41ec-99d5-4241-9850-18bb4475cfe2/iso-9100-6-2005>

## 1 Scope

This document specifies the dimensions of vacuum lug finishes with nominal sizes of 53 mm and 58 mm regular for wide-mouth glass containers.

## 2 Normative references

Not applicable.

## 3 Dimensions

3.1 The design and dimension of the finish shall be as shown in Figures 1 to 3 and Table 1.

3.2 Details which are not specified shall be selected in accordance with the application. For general tolerances see EN 22768-1.

Dimensions in millimetres

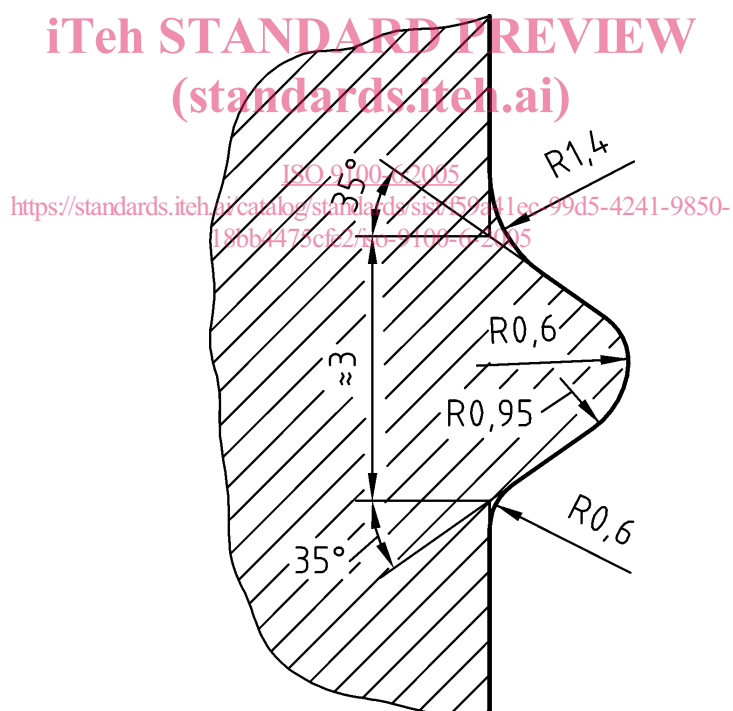
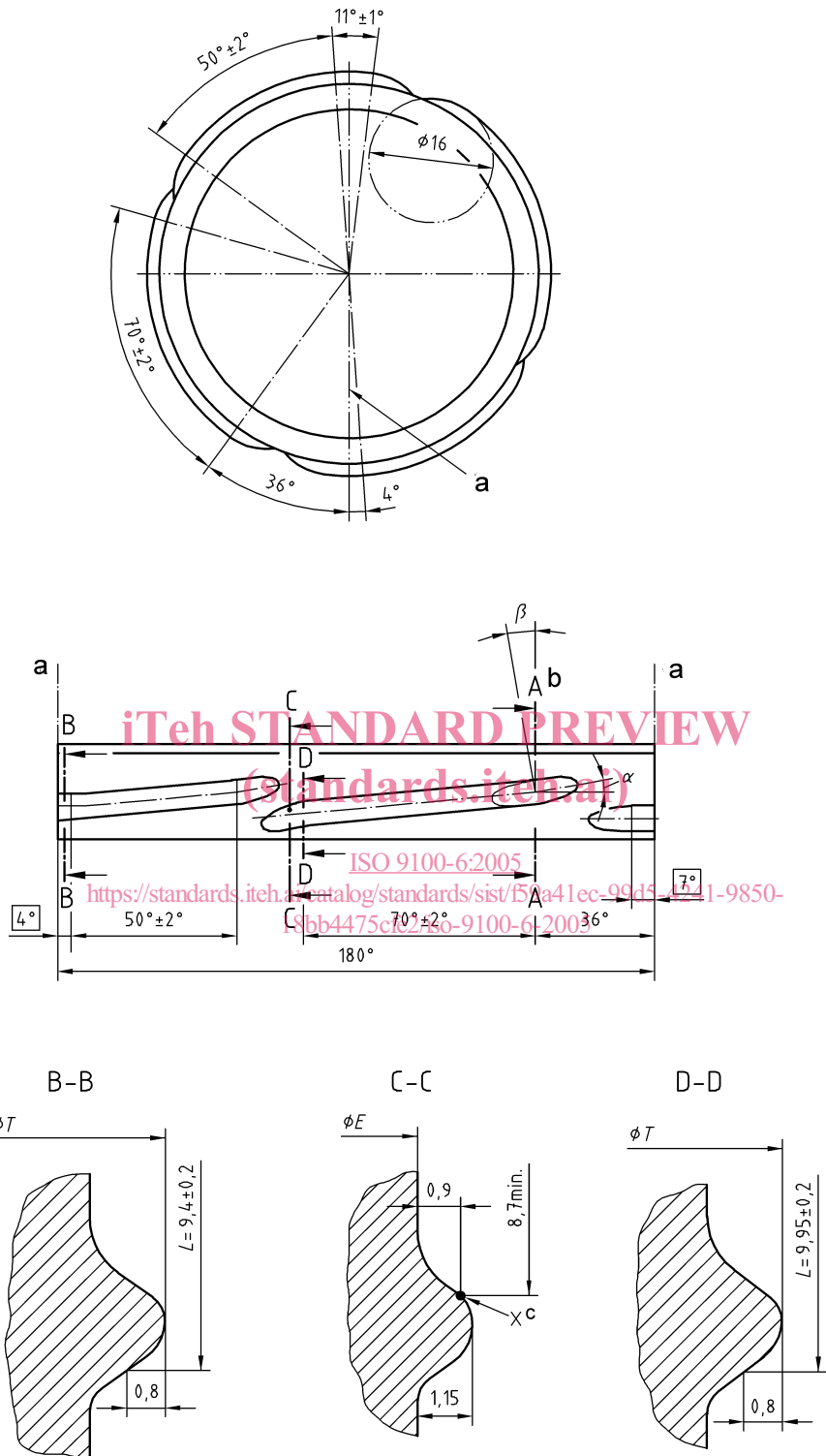

Figure 1 — Cutter profile



**Key**

- a) Parting line
- b) See Figure 3
- c) In order to provide a proper cap removal, the theoretical cam-off point (X) shall be on the upper flank of the thread.

**Figure 2 — Thread construction and enlarged view sections B-B, C-C and D-D**

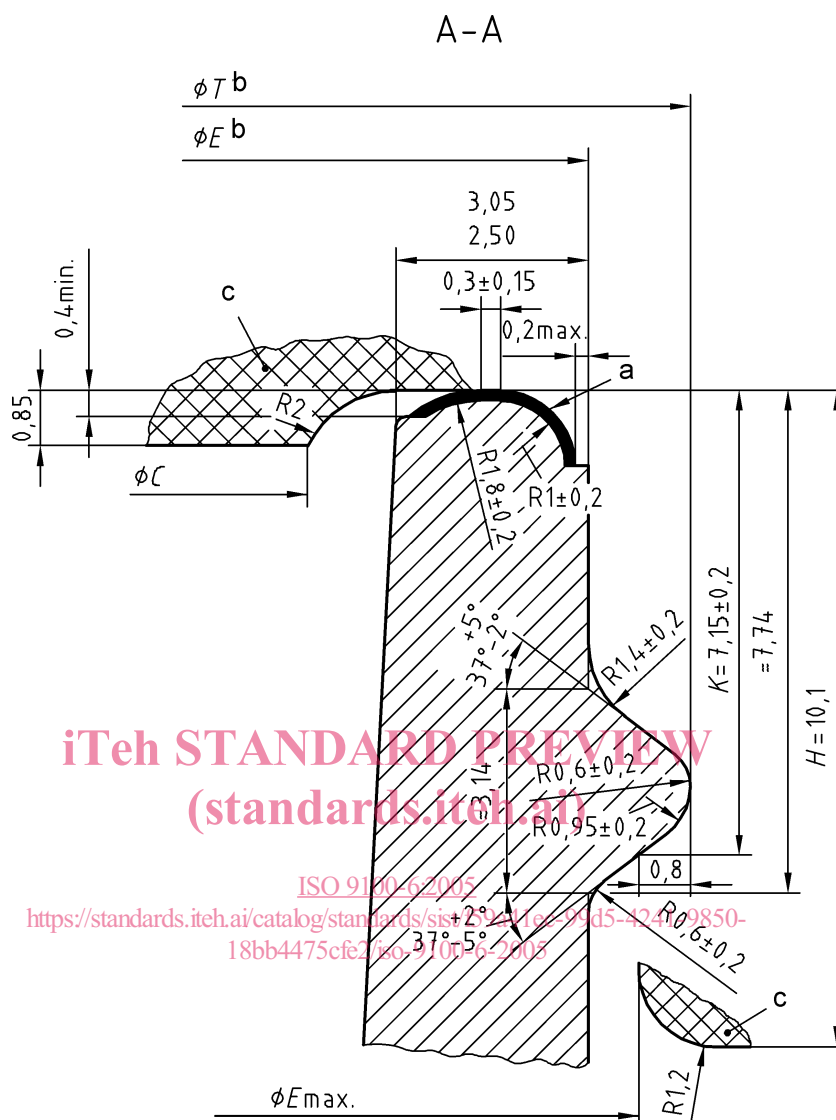

**Key**

- a) The sealing surface shall be free of checks, dips, crizzles and other defects which may affect proper functioning.
- b) Proper system functioning calls for keeping the ovality in the finish diameters to a minimum. E and T diameters should be concentric in relation to one another.
- c) Cross-hatched areas of C diameter and H height show the closure position. Glass shall clear cap limits shown. The contour below the H dimension as well as the design of a possible bead are optional. Sufficient free space shall be provided between the bead and the cross-hatched area.

**Figure 3 — Enlarged view section A-A**