



Designation: D 3737 – 04

Standard Practice for Establishing Allowable Properties for Structural Glued Laminated Timber (Glulam)¹

This standard is issued under the fixed designation D 3737; the number immediately following the designation indicates the year of original adoption or, in the case of revision, the year of last revision. A number in parentheses indicates the year of last reapproval. A superscript epsilon (ϵ) indicates an editorial change since the last revision or reapproval.

1. Scope

1.1 This practice covers the procedures for establishing allowable properties for structural glued laminated timber. Properties considered include bending, tension and compression parallel to the grain, modulus of elasticity, horizontal shear, compression perpendicular to the grain, and radial stresses in curved members.

1.2 This practice is limited to the calculation of allowable properties subject to the given procedures for the selection and arrangement of grades of lumber of the species considered.

1.3 Requirements for production, inspection, and certification are not included, but in order to justify the allowable properties developed using procedures in this practice, manufacturers must conform to recognized manufacturing standards. Refer to [ANSI/AITC A190.1](#) and [CSA 0122](#).

1.4 Allowable properties established by use of this practice are based on dry conditions of use (less than 16 % moisture content). Modifications for wet-use conditions are given in [9.2](#).

1.5 The values stated in inch-pound units are to be regarded as standard.

1.6 *This standard does not purport to address all of the safety concerns, if any, associated with its use. It is the responsibility of the user of this standard to establish appropriate safety and health practices and determine the applicability of regulatory limitations prior to use.*

2. Referenced Documents

2.1 ASTM Standards:²

- D 198 Test Methods of Static Tests of Lumbers in Structural Sizes
- D 245 Practice for Establishing Structural Grades and Related Allowable Properties for Visually Graded Lumber
- D 2395 Test Methods for Specific Gravity of Wood and

Wood-Base Materials

- D 2555 Test Methods for Establishing Clear Wood Strength Values
- D 2915 Practice for Evaluating Allowable Properties for Grades of Structural Lumber
- D 4761 Test Methods for Mechanical Properties of Lumber and Wood-Base Structural Material
- E 105 Practice for Probability Sampling of Materials

2.2 Other Standards:

- ANSI/AITC A190.1 Structural Glued Laminated Timber³
- ANSI/AF&PA National Design Specification for Wood Construction⁴
- CSA 0122 Structural Glued Laminated Timber⁵

3. Terminology

3.1 Definitions:

3.1.1 *E-rated lumber*—lumber graded for use in manufacturing glued laminated timber by nondestructive measurement of a modulus of elasticity (E) and by visual inspection in accordance with the grading rules of the applicable grading or inspection agency.

3.1.2 *glulam*—a term used to denote glued laminated timber, which is a product made from suitably selected and prepared pieces of wood bonded together with an adhesive either in a straight or curved form with the grain of all pieces essentially parallel to the longitudinal axis of the member.

3.1.3 *horizontally laminated timber*—a member designed to resist bending loads applied perpendicularly to the wide faces of the laminations (referred to as the $x-x$ axis).

3.1.4 *lamination*—a layer of lumber within the glued laminated timber.

3.1.5 *modulus of elasticity (E)*—for laminating, E is designated in two categories to distinguish mode of measurement and application.

3.1.5.1 *Long-Span E (LSE)*—the E calculated from deflection measured in a flat-wise static bending test of lumber with

¹ This practice is under the jurisdiction of ASTM Committee D07 on Wood and is the direct responsibility of Subcommittee D07.02 on Lumber and Engineered Wood Products.

Current edition approved Nov. 1, 2004. Published November 2004. Originally approved in 1978. Last previous edition approved in 2003 as D 3737 – 03.

² For referenced ASTM standards, visit the ASTM website, www.astm.org, or contact ASTM Customer Service at service@astm.org. For *Annual Book of ASTM Standards* volume information, refer to the standard's Document Summary page on the ASTM website.

³ Available from the American Institute of Timber Construction, 7012 S. Revere Parkway, Suite 140, Englewood, CO 80112.

⁴ Available from American Forest and Paper Association (AF&PA), 1111 19th St., NW, Suite 800, Washington, DC 20036.

⁵ Available from Canadian Standards Association (CSA), 178 Rexdale Blvd., Toronto, ON Canada M9W1R3.

a center point loading and a span-to-depth ratio (l/d) of approximately 100 or the E Test Methods D 2555 and multiplying by the appropriate factors from **Table 1**.

3.1.5.2 *Member E* (E_{axial} , E_x , E_y)—the allowable E values of the glued laminated member as defined in this practice.

3.1.6 *vertically laminated timber*—a member designed to resist bending loads applied parallel to the wide faces of the laminations (referred to as bending about the y - y axis).

3.1.7 *visually graded lumber*—lumber graded by visual inspection in accordance with the grading rules of the applicable grading or inspection agency.

3.2 *Symbols:*

3.2.1 GDE —ratio of the cross-sectional area of the local grain deviation (which may or may not be associated with a knot) at the edge of the lumber to the cross sectional area of the lumber (see **Fig. 1**).

3.2.2 GDC —ratio of the cross-sectional area of the local grain deviation (which may or may not be associated with a knot) away from the edge of the lumber to the cross-sectional area of the lumber (see **Fig. 1**).

3.2.3 GDS —the projected sum of all GDE and GDC values within a one-foot length of lumber as defined in **Fig. 1**.

3.2.4 KE —the ratio of cross-sectional area of knot at the edge of wide face of lumber to the cross-sectional area of the lumber (see **Fig. 2**).

3.2.5 KC —ratio of the cross-sectional area of knot located away from the edge of the lumber to the cross-sectional area of lumber. When a knot at the edge of the wide face and a knot located away from the edge are in the same cross-section, the combination of the two shall be used in determining KC (see **Fig. 2**).

3.2.6 SR_u —strength ratio of the tension lamination at the outermost fiber.

4. Requirements for Laminations

4.1 Individual laminations shall not exceed 2 in. (51 mm) in net thickness. Lumber may be end-jointed to form any length of lamination or placed edge-to-edge to form any width, or both. When the member is subjected to loads parallel to the wide face of the laminations or when the member is subjected to torsion stresses, edge gluing of the laminations may be required to develop the required shear strength at the edge to edge joints.

4.2 All lumber shall be graded as either visually graded or E -rated lumber prior to laminating the member and suitably marked or segregated to identify its grade.

4.2.1 When pieces are ripped, each piece shall conform to applicable grade requirements. E -rated lumber shall be re-

graded for E after ripping except that regrading may be waived if both the E and tensile strength are monitored by quality control procedures referenced in ANSI A190.1, section 4.3.5.

4.2.2 If lumber is to be qualified by test as equivalent to visually graded or E -rated lumber, the procedures of Annex A shall be followed.

4.2.3 E -rated lumber shall have special visual provisions applied to those portions not subjected to mechanical test to assure piece quality.

4.3 The effect of decay or compression failures upon strength cannot be readily determined, thus these defects shall be prohibited from laminating grades insofar as existing inspection and grading technology permit. Firm white speck or light white pocket is permissible in grades of lumber that permit knots to occupy up to one third or more of the cross section provided their extent in combination with knots does not exceed that of the largest edge knot permitted. The exception is that firm white speck and light white pocket shall be excluded from end joints in tension members and the outer 10 % of the total depth on the tension side of bending members.

4.4 Compression wood in readily identifiable and damaging form shall be limited in accordance with 4.4.1 and 4.4.2.

4.4.1 For dry service conditions, grades permitting knots up to one half of the cross section may contain streaks of compression wood occupying as much as 20 % of the cross section. Streaks of compression wood up to one eighth of the cross section may be permitted in other grades.

4.4.2 For wet service conditions, or for pressure-treated members, the conditions of 4.4.1 apply except that compression wood is limited to 5 % of the cross section of the laminations in tension members and in the outer 10 % of the total depth on the tension side of bending members.

4.5 Lumber shall be free of shakes and splits that make an angle of less than 45° with the wide face of the piece. Pitch pockets shall be limited in size to the area of the largest knot permitted, and pitch streaks shall be limited to one sixth of the width of the lumber.

4.6 For wet service conditions, wane is limited to that which will be removed upon final surfacing of the member. For dry service conditions, wane up to one sixth the width of the lumber is permitted at each edge provided the allowable shear strength is adjusted to consider this unbonded region.

4.7 The range of moisture content of lumber for assembly into a single member shall not exceed five percentage points, except when all the lumber is 12 % or lower. The maximum moisture content of individual laminations is 16 %, unless the in-service conditions are wet service and in this case the maximum is 20 %.

5. Allowable Properties for Glued Laminated Timber Members

5.1 Allowable properties for specific members can be obtained by multiplying the stress index values from Section 6 by the stress modification factors from Section 7 or 8 and modifying for specific conditions from Section 9. Exceptions are described in 5.3-5.6.

5.2 Allowable properties shall be rounded to the significant digits as shown in the following table:

TABLE 1 Adjustment Factors for Clear Wood Stresses (Test Methods D 2555)

Property	Multipliers for Average or Lower Exclusion Limit		Seasoning Factor for a 12 % Average Moisture Content
	Softwoods	Hardwoods	
Bending	0.476	0.435	1.35
Compression parallel to grain	0.526	0.476	1.75
Modulus of elasticity	1.095	1.095	1.20
Horizontal shear	0.244	0.222	1.13

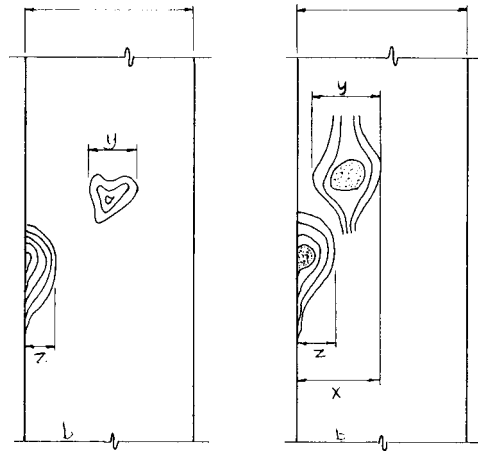

(a)

(b)

$GDC = y/b$

$GDE = z/b$

$GDS = x/b$ where $x = y + z$

(a) Example of grain deviations not associated with a knot where the projected grain deviations do not overlap.

$GDC = y/b$

$GDE = z/b$

$GDS = x/b$ where $x < y + z$

(b) Example of grain deviations associated with knots where the projected grain deviations overlap.

FIG. 1 Knot and Grain Deviation Measurement at the Outer 5% on the Tension Side of a Member Occurring in a 1-ft Length

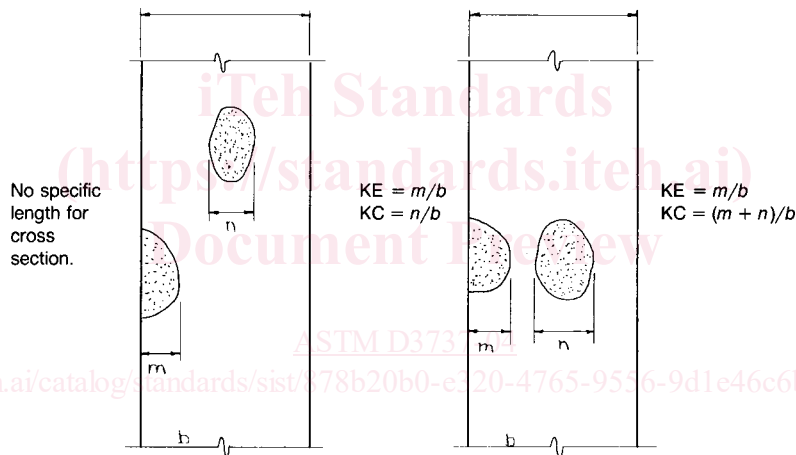

No specific length for cross section.

$KE = m/b$
 $KC = n/b$

$KE = m/b$
 $KC = (m + n)/b$

NOTE 1—When edge knots and centerline knots occur at the same cross section, the sum of the edge knots and centerline knots is used in calculating KC as shown in (b).

FIG. 2 Knot Measurement for the Next Inner 5% on the Tension Side of a Bending Member

Bending, tension parallel to grain, and compression parallel to grain	0 to 1000 psi to nearest 25 psi (0.3 MPa) 1000 to 2000 psi; to nearest 50 psi (0.5 MPa) 2000 to 3000 psi; to nearest 100 psi (1 MPa)
Horizontal shear	Nearest 5 psi (0.05 Mpa)
Compression perpendicular to grain and radial stresses in curved members	Nearest 5 psi (0.05 MPa)
Modulus of elasticity	Nearest 100 000 psi (500 MPa)
Calculations shall be rounded only for the final allowable property.	

5.3 Allowable properties for bending of vertically laminated members (bending about the y-y axis) using two or more grades of lumber shall be determined by the following equation:

$$f_{by} = E (f_{bx}/E)_{min} \quad (1)$$

where:

- f_{by} = allowable bending property of the vertically laminated beam combination made up of two or more grades of lumber,
- E = weighted average of the component lamination LSE values,
- $(f_{bx}/E)_{min}$ = ratio of allowable bending property to LSE for each grade of lumber in the beam combination. The lowest ratio is used in Eq 1,
- f_{bx} = allowable bending property for a grade in the combination, which is obtained by multiplying the stress index value from Section 6 by the stress modification factor calculated using Eq 4 and modifying for specific conditions from Section 9, and

E = corresponding *LSE* for a grade in the combination.

5.4 The modulus of rigidity of glued laminated members can be considered to have a constant relationship to the modulus of elasticity. For design purposes, the relationship $G = E_x/16$ is satisfactory for members consisting of a single grade. A conservative approximation for members consisting of multiple grades of lumber can be obtained by using the *LSE* of the lowest grade applied to the entire member.

5.5 *Radial Stress in Curved Members:*

5.5.1 *Radial Tension*—Allowable properties for radial tension in curved members shall be limited to one third of the value for horizontal shear as determined in accordance with 6.1.5, except for Douglas fir-Larch and Hem-fir, which are limited to 15 psi (0.10 MPa) for other than wind or earthquake loads. For wind and earthquake loading of all species, adjustments to the allowable property shall be based on one third of the value for horizontal shear.

5.5.2 *Radial Compression*—Allowable properties for radial compression in curved members shall be limited to the allowable property for compression perpendicular to the grain.

5.6 *Member E:*

5.6.1 *Axially Loaded, Symmetric Combinations*—Allowable E_{axial} is determined by using the weighted average of the individual lamination grade *LSE* values. *LSE* is determined according to procedures in 3.1.5.1 or by alternate procedures in 6.2.4.1.

5.6.2 *Vertically Laminated Combinations*—Allowable E_y is determined by the procedure in 5.6.1 and further adjusting by multiplying by 0.95.

5.6.3 *Horizontally Laminated Combinations*—Allowable E_x is determined by a transformed section analysis and further adjusted by multiplying by 0.95, such as shown in Annex A4.

6. **Stress Index Values**

6.1 *Visually Graded Lumber*—Test Methods D 2555 provides information on clear wood strength properties and their expected variation for small clear, straight-grained specimens of green lumber. Based on these properties, stress index values shall be calculated.

6.1.1 *Bending*—Determine a stress index value by calculating the fifth percentile of modulus of rupture in accordance with Test Methods D 2555, multiplying by the appropriate factors in Table 1, and furthermore multiplying by 0.743 to adjust to a 12-in. (0.3-m) deep, uniformly loaded simple beam with a 21:1 span-to-depth ratio.

6.1.1.1 Tests of large glued laminated timber beams of Douglas fir-Larch, southern pine, and Hem-Fir indicate that the stress index value in bending, based on test and analysis and given in Table 2, may be used instead of the procedure in 6.1.1 for Douglas fir-Larch, grown within the states of Wyoming, Montana, Washington, Idaho, Oregon, and California; for southern pine consisting of the four principal species: longleaf, slash, shortleaf, and loblolly; and for Hem-Fir consisting of Western Hemlock, California Red Fir, Grand Fir, Noble Fir, Pacific Silver Fir, and White Fir.

6.1.2 *Compression Parallel to the Grain*—Determine a stress index value by calculating the fifth percentile of compression parallel to the grain in accordance with Test Methods D 2555 and multiplying by the appropriate factors from Table 1.

6.1.3 *Tension Parallel to the Grain*—Determine a tension value by using 5/8 of the bending stress index for 12-in. (0.3-m) deep members obtained in 6.1.1.

6.1.4 *Modulus of Elasticity*—Obtain a stress index value from an average modulus of elasticity for the species or species group from Test Methods D 2555. From that, obtain *LSE* by multiplying by the appropriate factors from Table 1. This adjusts values to a span-to-depth ratio of 100:1 and an assumed uniform loading.

6.1.4.1 The modulus of elasticity values in Table 2 are *LSE* values based on testing of large samples of lumber of the species groups listed in 6.1.1.1 and may be used instead of values determined by the method in 6.1.5.1.

6.1.5 *Horizontal Shear*—Determine a stress index value by calculating the lower fifth percentile tolerance limit of clear wood shear strength in accordance with Practice D 2915 using the data given in Test Methods D 2555 and multiplying by the appropriate factors from Table 1. The horizontal shear stress

TABLE 2 Bending Stress Index Based on Large Beam Tests and Modulus of Elasticity Values for Visually Graded Lumber

NOTE 1—Appendix X1 provides one method of developing new data.

Species	Growth Classification ^A	Bending Stress Index ^B		Modulus of Elasticity	
		psi	MPa	million psi	MPa
Douglas Fir-Larch	medium grain	3 000	20.7	1.9	13 100
	close grain	3 250	22.4	2.0	13 800
	dense	3 500	24.1	2.1	14 500
Southern Pine	coarse grain ^C	2 000	13.8	1.5	10 300
	medium grain	3 000	20.7	1.8	12 400
	dense	3 500	24.1	2.0	13 800
Hem-Fir	medium grain	2 560	17.7	1.7	11 700
	dense ^D	3 000	20.7	1.8	12 400

^A Classification for “dense” wood shall follow Practice D 245.

^B Values shown are based on full-size beam tests. As a result, these values incorporate the effects of some features such as grain deviations in lumber along with influences of end and face bonding influences. Beams designed using these values and tested in accordance with Test Methods D 198 will yield strength values such that the lower fifth percentile will exceed the design bending stress by a factor of 2.1 with 75 % confidence. Analysis of test data assumed a log normal distribution. For unsymmetric combinations, tests have shown that values up to 40 % higher than those listed may be applied to the compression side of bending members.

^C Also applicable to minor species of southern pine regardless of growth rate.

^D Specific gravity, based on oven-dry weight and volume at 12 % moisture content, must equal or exceed 0.39.

index for coarse-grain Douglas fir-Larch and southern pine shall be 70 % of the value used for medium-grain materials.

6.1.5.1 As an alternative to 6.1.5, the horizontal shear stress index shall be permitted to be determined from flexural tests of full-size beams in accordance with the principles of Test Methods D 198 with specific loading details as shown in Annex A7. Laminating lumber used in the critical core area of the test beams subjected to maximum shear stresses shall be selected such that it is representative of the population of on-grade lumber used in normal production for the species and grade being evaluated. The required number of samples and the lower fifth percentile tolerance limit of shear strength shall be determined in accordance with Practice D 2915 and the analysis procedures given in Annex A7. The horizontal shear stress index is determined by multiplying the lower fifth percentile tolerance limit of shear strength by 1/2.1. Reassessment of the horizontal shear stress index derived from this section shall be conducted for beam configurations that are not included in the consideration of the testing described in this section, or if there is a significant change in the lumber resource or in the lamination grading system or the manufacturing process.

6.1.6 *Compression Perpendicular to the Grain*—Determine a stress index value as follows (1):⁶

$$F_{C\perp} = (2674 SG - 551.3) (1.9/1.67) \quad (2)$$

where:

$F_{C\perp}$ = stress index value in compression perpendicular to grain, and

SG = average green specific gravity from Test Methods D 2555 or, for a species group, the standing timber volume weighted average green specific gravity, adjusted as shown in 6.1.6.1, 6.1.6.2, or 6.1.6.3.

6.1.6.1 For purposes of calculating stress index values in compression perpendicular to grain for visually graded material, the average green specific gravity of a species or species group that have an average green specific gravity of 0.36 or above shall be reduced by the following amounts for various rates of growth and density to account for variation in the specific gravities.

- Dense grain—0.03
- Close grain—0.05
- Medium grain—0.06
- Coarse grain—0.09

6.1.6.2 When the average green (specific gravity) of a species or species group is 0.35 or less, the reductions are as follows:

- Close grain—0.03
- Medium grain—0.04

6.1.6.3 As an alternative to the method specified in 5.6.1 of Practice D 245, lumber shall be qualified as dense by weighing. The lumber specific gravity, adjusted to a green condition using Test Methods D 2395, Appendix X1 conversion formula, shall meet the reduced specific gravity as specified in 6.1.6.1. The reduced value shall be used in Eq 2 to determine the stress index value in compression perpendicular to grain.

6.2 *E-rated Lumber*—This method is based on lumber that has been *E*-rated and visually graded in accordance with Annex A1. *E*-rated lumber is designated by the modulus of elasticity and the size of the edge characteristics permitted in the grade such as 1.6*E*-1/3, and so forth. Edge characteristics include knots, knot holes, burls, localized grain deviation, or decay (partially or wholly) at edges of wide faces.

6.2.1 Bending stress index values for lumber with various *LSE* values are given in Table 3.

6.2.1.1 Stress index values in bending for *E*-rated lumber shall be no lower than those for visually graded lumber in Table 2 for the same species and equal *LSE*. Also, the stress index values of any *E*-rated grade of a specific species shall be no lower than that of a No. 3 visual grade of lumber provided the long span *E*'s are comparable (No. 3 grade structural lumber is defined in most grading rules).

6.2.2 Compression parallel to grain stress index values are included in Table 3.

6.2.3 *Tension Parallel to the Grain*—Determine a tension by using 5/8 of the bending stress index for 12-in. (0.3-m) deep members obtained in 6.2.1.

6.2.4 *Modulus of Elasticity*—The *E* values for *E*-rated lumber shall be the *LSE* as defined in 3.1.5.1.

6.2.4.1 *LSE* values may be determined by tests of lumber using the procedure of Annex A1 and meeting the criteria of Annex A2.

6.2.5 *Horizontal Shear*—The stress index value shall be determined in the same manner as for visually graded lumber in 6.1.5.

6.2.6 *Compression Perpendicular to Grain*—Stress indexes for *E*-rated lumber are determined by using the *LSE*-rated grade listed in Table 3 and the growth classifications.

(1) *Dense*—If the *LSE* equals or exceeds that of the dense classification for the species, the stress index for the dense visual grade of the species or species group is used per 6.1.6.

(2) *Medium Grain*—If the *LSE* of the *E*-rated grade of lumber is less than the average *LSE* of the species or species groups, but no less than 300 000 psi below the average, use the compression perpendicular to grain value determined for medium grain lumber per 6.1.6.

(3) *Other*—When the *LSE* is less than the average *LSE* minus 300 000 psi, determine the compression perpendicular to grain values by using a specific gravity of 0.8 times the average specific gravity of the species in solving Eq 2. (The value obtained is approximately the same as that used for coarse grain lumber.)

TABLE 3 Bending Stress Indexes and Compression Stress Index Parallel to Grain for *E*-Rated Lumber Used in Laminating^A

Long Span, <i>E</i> , psi	Bending Stress Index, ^A psi	Compression Stress Index Parallel to Grain, ^{B,C} psi
1 600 000	2 560	1 900
1 900 000	3 000	2 400
2 100 000	3 500	2 800
2 300 000	4 000	3 100

^A Values shall be not higher than obtained by interpolation for intermediate *E* values.

^B Values are for 12-in. deep members at 12 % moisture content (dry).

^C Values are for members at 12 % moisture content (dry) values.

⁶ The boldface numbers in parentheses refer to a list of references at the end of this practice.

6.2.6.1 As an alternative to 6.2.6, the allowable property for compression perpendicular to grain may be determined in accordance with the applicable provisions of Refs (2-5).

7. Procedure for Determining Stress Modification Factors (SMF) for Glued Laminated Timber Made of Visually Graded Lumber

7.1 For some strength properties, knots, slope of grain, and other characteristics may affect the strength, and therefore reductions in the stress index values are required. Conversely, some properties are not affected by these characteristics and no modification is necessary.

7.1.1 Special tension lamination grades of lumber as described in Section 10 are required to justify the bending stress modifications.

7.2 *Bending Stress Modification Factor*—The bending stress modification factor is the lower of the two modification factors determined on the basis of knots and on the basis of slope of grain.

7.2.1 The bending stress modification factor for members loaded perpendicular to the wide faces of the laminations (horizontally laminated beams) shall be determined as follows:

7.2.1.1 *Knots*—Knots affect strength less if located in laminations near the neutral axis than in outer laminations. Thus, the influence of knots depends both on their size and position and is best measured by their moment of inertia. Tests of glulam beams have provided an empirical relationship between the ratio I_K/I_G and bending strength. I_K is defined as the moment of inertia of all knots within 6 in. (152 mm) of the critical cross section and I_G is the gross moment of inertia. Knot properties shall be determined following the procedures given in Annex A3 and I_K/I_G ratios shall be calculated following procedures given in Annex A4. Additional information is given in Refs (6 and 7). Determine the stress modification factor in bending from the following relationship:

$$SMF_b = (1 + 3R)(1 - R)^3(1 - R/2) \tag{3}$$

where:

SMF_b = bending stress modification factor, and
 R = I_K/I_G ratio.

For multiple grade laminations, several SMF_b values are calculated and compared as shown in Annex A4.

The minimum value of SMF_b shall not be less than the strength ratio in flatwise bending as determined by formula X1.2 of Practice D 245.

7.2.1.2 *Slope of Grain*—Modification factors associated with various slopes of grain are given in Table 4. Those given for tension apply to lumber in the tension side of bending members while those given for compression apply to that in the compression side.

7.2.2 The bending stress modification factor for vertically laminated beams (members loaded parallel to the wide faces of the laminations) shall be determined as follows:

7.2.2.1 *Knots*—Determine the effect of knots on vertically laminated beams of a single grade of lumber by calculating a

TABLE 4 Parallel to Grain Stress Modification Factors Associated with Slope of Grain for Designing Glulam Combinations

Slope of Grain	Stress Modification Factor	
	Tension	Compression
1:4	0.27	0.46
1:6	0.40	0.56
1:8	0.53	0.66
1:10	0.61	0.74
1:12	0.69	0.82
1:14	0.74	0.87
1:15	0.76	1.00
1:16	0.80	1.00
1:18	0.85	1.00
1:20	1.00	1.00

stress modification factor, SMF , by the following empirical relationship (see Ref (8) for further details):

$$SMF = C_1(SR_1^\gamma)(N^\alpha)(1 - 1.645 \Omega_1/N^{1/2}) \tag{4}$$

where:

- C_1 = empirical constant from Table 5,
- SR_1 = strength ratio from Practice D 245 for an individual piece of lumber loaded on edge,
- γ = empirical constant equal to 0.81,
- α = $0.329(1 - 1.049SR_1)$,
- N = number of laminations in the member of the same grade or higher up to 5. Use $N = 5$ for members with five or more laminations of the same grade or higher, and
- Ω_1 = coefficient of variation of bending strength for one lamination. The coefficient of variation for one lamination of visually graded lumber = 0.36.

7.2.2.2 *Slope of Grain*—Bending stress modification factors associated with various slopes of grain are equal to those for tension stress in Table 4 assuming the steepest slope of grain permitted in the grade.

7.3 Stress Modification Factors in Compression Parallel to the Grain:

7.3.1 The modification factor is the lower of the two modification factor ratios determined separately from both knots and slope of grain as follows:

7.3.2 *Knots*—Tests have shown that axial compressive strength of short compression members is related to the percent of the cross section occupied by the largest knot for individual laminations. Procedures for estimating values of this percentage for compression members are given in Annex A5. Derive

TABLE 5 Constant Used to Adjust Vertically Laminated Bending Strength Ratio

Strength Ratio (SR_1)	C_1
0.45 or greater	1.238
0.40	1.292
0.35	1.346
0.30	1.400
0.26 or less	1.444

the stress modification factor in compression from the following empirical relationship.

$$SMF_c = Y^3/4 - Y^2 - Y/4 + 1 \quad (5)$$

where:

SMF_c = compression stress modification factor, and
 Y = knot size at the 99.5 percentile, expressed in a decimal fraction of the dressed width of lumber used for the lamination.

For members with grades of lumber placed unsymmetrical, an additional adjustment, such as given in **Annex A5**, is necessary to compensate for additional bending stresses.

7.3.3 Slope of Grain—Modification factors in compression associated with various slopes of grain are given in **Table 4**. When compression members consist of different grades, determine a weighted average stress modification factor.

7.3.4 The modification factor in compression parallel to grain for members of two or three laminations of the same grade of lumber shall be the same as the strength ratio determined using Practice D 245 for a single piece of lumber of the grade being used.

7.4 Stress Modification Factors in Tension Parallel to the Grain:

7.4.1 The modification factor to use in determining allowable properties is the lower of the two modification factors determined on the basis of knots and on the basis of slope of grain as follows:

7.4.2 Knots—Determine the modification factor in tension as governed by knots as follows:

$$SMF_t = 1 - Y_2 \quad (6)$$

where:

SMF_t = tensile stress modification factor, and
 Y_2 = maximum edge knot size permitted in the grade expressed in a decimal fraction of the dressed width of the wide face of the piece of lumber used for the lamination. (Centerline knot size shall be limited to that resulting in an equivalent edgewise bending strength ratio as determined by Practice D 245.)

7.4.3 Slope of Grain—Stress modification factors in tension are given in **Table 4**.

7.5 Member Modulus of Elasticity (E):

7.5.1 The E_x of glulam members is directly dependent upon the LSE of laminations used in its manufacture. When LSE is determined by test methods other than those described in **3.1.5.1**, then modification factors described in Section 4.3 of Practice D 2915 shall be applied. When LSE is determined using the Test Methods D 2555 procedures described in **3.1.5.1**, then modification factors from **Table 6** shall be applied.

TABLE 6 Grade Adjustment Factors for Modulus of Elasticity

Bending Strength Ratio ^A	Adjustment Factor
0.55 or greater	1.00
0.45 to 0.54	0.90
0.44 or less	0.80

^A Determined in accordance with Practice D 245.

7.5.1.1 The E values given in **Table 2** may be used as alternatives to those determined from **7.5.1**. These values were determined by surveys of laminating grades adjusted to standard test conditions.

7.5.2 The E values for axially loaded symmetric combinations of members shall be assumed to be the weighted average of the component lumber used in the member.

7.5.3 The E values applicable to vertically laminated combinations shall be 95 % of the average of the laminations.

7.5.4 E values applicable to horizontally laminated bending combinations shall be 95 % of the value calculated by the transformed section analysis (see **Annex A4**).

7.6 Horizontal Shear:

7.6.1 Horizontally Laminated Members—By restricting shakes and splits as given in **4.5**, the modification factor for horizontal shear in horizontally laminated members is 1.0.

7.6.1.1 For wet service conditions, wane is limited to an amount that will be removed during final surfacing of the member and a stress modification of 1.0 is applicable. For dry service conditions, the stress modification factor in horizontal shear is calculated as the ratio of the wane-free width to total surfaced width. Thus, when wane up to 1/6 of the width is allowed along both edges, the stress modification factor is 2/3.

7.6.2 Vertically Laminated Timbers—For members consisting of four or more laminations, one out of four pieces is assumed to have a check or split that limits its modification factor in shear to 1/2 resulting in a modification factor of the composite of 7/8. For two and three lamination beams, the modification factor is 3/4 and 5/6, respectively. When species having different shear properties are combined in a glued laminated timber, use a weighted average to determine the stress index value in shear.

7.7 Stress Modification Factor for Compression Perpendicular to Grain and Radial Tension:

7.7.1 A stress modification factor of 1.0 shall be applicable to glulam combinations.

8. Procedure for Determining Stress Modification Factors (SMF) for Glued Laminated Timber Made of E -Rated Lumber

8.1 The determination of the stress modification factors for glued laminated timbers made with E -rated lumber is similar to that for visually graded lumber except that the effect of slope of grain is accounted for in the LSE value and slope of grain stress modification factors are not used. However, the tension laminations prescribed for the outer 5 % of bending members have specific slope of grain restrictions. See **10.2.3.1**.

8.2 Bending Stress Modification Factor:

8.2.1 Horizontally Laminated Members—Determine the bending stress modification factor by the I_K/I_G method used for members made of visually graded lumber as shown in **Annex A4**.

8.2.1.1 The minimum stress modification factor shall not be less than the modification factor given in **Table 7** for members 15 in. or less in depth.

8.2.2 Vertically Laminated Members—Determine the bending stress modification factor by use of Eq 4. The coefficient of variation, COV , for E -rated lumber for use in Eq 4 is 0.24, except where the edge characteristics occupy one half of the

TABLE 7 Minimum Bending and Compression Parallel to Grain Stress Modification Factors for Members of E-Rated Lumber

Edge Characteristic Designation ^A	Minimum Stress Modification Factor (SMF)		
	Horizontally Laminated Bending	Vertically Laminated Bending	Compression Parallel to Grain
1/6	0.80	0.70	0.80
1/4	0.75	0.65	0.75
1/2	0.50	0.25	0.50

^A The edge characteristic designation indicates fraction of cross section that can be occupied by edge characteristics, which include knots, knot holes, burls, distorted grain, or decay partially or wholly at edges of wide faces.

cross section, in which case, the coefficient of variation is the same as for visually graded lumber (0.36).

8.3 Stress Modification Factor for Compression Parallel to Grain:

8.3.1 The modification factor is based on a knot size study as shown for visually graded lumber in 7.3.2 and Annex A5.

8.4 Stress Modification Factor in Tension Parallel to Grain:

8.4.1 Determine the modification factor in tension that is governed by knots using Eq 6 and procedures of 7.4.2 with the exception that only edge knots are considered in determining Y_2 .

8.5 Stress Modification Factor for E:

8.5.1 Use the same procedure as given in 7.5.1.

8.6 Stress Modification Factor for Horizontal Shear:

8.6.1 The modification factor for horizontal shear is determined in the same manner used for visually graded lumber in 7.6.

8.7 Stress Modification Factor for Compression Perpendicular to Grain and Radial Tension:

8.7.1 A stress modification factor of 1.0 shall be applicable to glulam combinations.

9. Adjustment of Properties for End-Use Conditions

9.1 The allowable properties developed using Sections 6-8 are based on normal load duration (9.3), 12 % average moisture content conditions, and approximately 68°F (20°C) temperatures. Bending stress is for a 12-in. (0.3-m) deep straight beam, uniformly loaded with a 21:1 span-to-depth ratio. Design at other conditions requires modifications.

9.2 *Moisture Content*—Two different moisture conditions are recognized for glulam members, dry service and wet service. Dry service is the use condition where the moisture content of the wood is less than 16 %. Wet service is the use where wood attains moisture contents of 16 % or more. For wet service conditions, properties developed using Sections 6-8 should be multiplied by factors given in Table 8.

9.3 *Duration of Load*—Normal load duration contemplates fully stressing a member to its allowable value either continuously or cumulatively for ten years. For other durations of load,

TABLE 8 Wet-Use Adjustment Factors

Type of Stress	Wet-Use Factor
Bending	0.800
Compression parallel to the grain	0.730
Tension parallel to the grain	0.800
Modulus of elasticity	0.833
Horizontal shear	0.875
Compression perpendicular to the grain	0.530

all properties except E and compression perpendicular to grain may be modified in accordance with Practice D 245.

9.4 Effect of Member Size:

9.4.1 For bending members with the load applied parallel to the wide face of the laminations (vertically laminated members), the bending stress shall be adjusted for depths other than 12 in. (0.3 m) by multiplying by $(12/d)^{1/9}$ where d is the beam depth in inches or $(0.3/d)^{1/9}$ where d is the beam depth in meters.

9.4.2 For bending members with the load applied perpendicular to the wide face of the laminations (horizontally laminated members), the bending stress shall be adjusted for sizes greater than the standard size beam (as defined below) by multiplying by the volume effect factor, C_v , defined as follows:

$$C_v = [5.125/w]^{1/x} [12/d]^{1/x} [21/L]^{1/x} \leq 1.0 \quad (7)$$

where:

d = beam depth, in.,

w = beam width, in.,

L = length of beam between points of zero moment, ft, and

x = determined by procedures outlined in Annex A8.

The standard beam is assumed to be uniformly loaded and is defined as having a depth of 12 in. (0.3 m), a width of 5 1/8 in. (0.13 m), and a length of 21 ft (6.4 m). For other than uniformly loaded members, adjustments for method of loading (Table 9) are necessary.

9.5 *Curvature*—For the curved portion of members, the allowable bending property shall be modified by the following factor, $1 - 2000(t/R)^2$ where t is the lamination thickness and R is the radius of curvature, both in similar units of measurement. Experience has shown that in order to minimize breakage problems during manufacture, the t/R ratio should not exceed 1/100 for hardwoods and southern pine and 1/125 for other softwood species.

9.6 Treated Wood:

9.6.1 Allowable properties associated with preservative or fire-retardant treated members, whether the lumber is treated prior to gluing or the entire member is treated following gluing, must take into account possible reductions due to high temperatures, pressure, or chemical effects associated with the treating process. When reductions are applicable they must be based on tests of material subjected to the specific treatment conditions.

9.6.2 Members incised prior to preservative treatment may be subjected to a strength reduction depending on member size and the incision pattern and configuration. Such reductions must be based on tests of the incised material.

9.7 *Temperature*—Reductions in some allowable properties are applicable when the member is exposed to abnormally high temperatures, especially for extended periods of time, or for

TABLE 9 Bending Stress Adjustment Factors for Loading Conditions

Loading Conditions for Simply Supported Beams	Adjustment Factor
Single concentrated load	1.08
Uniform load	1.00
Third-point load	0.97

exposure combining high temperatures and high moisture content. Increases to some allowable properties may be applicable for members used in continuous cold climatic conditions. See guidelines given in Ref (9).

9.8 *Shear Deflection*—Member *E* values for bending combinations, calculated in accordance with 7.5 and 8.5 are applicable for a 21:1 span-to-depth ratio and assume that up to 5 % of the deflection will be due to shear and about 95 % due to bending when loaded uniformly. Such values may be applied to all loading conditions with span-to-depth ratios greater than 14:1 and the maximum deflection error due to shear will be of the order of 5 % or less. For more precise deflection calculations or for span-to-depth ratios less than 14:1, the effect of shear deflections should be considered separately.

10. Tension Laminations for Bending Members

10.1 The results of full-size beam tests reported in Refs (6, 10, and 11) have yielded an empirical relationship between the size of knots in the tension zone and bending strength. This relationship dictates that special grading considerations be applied to the laminations used in the outer 10 % of the beam depth on the tension side. This tension side may exist on the top or bottom of the beam, or both, depending upon design considerations. Consideration must be given to approximately matching the *LSE* or density of these tension grade laminations at end joints. When members are manufactured without these special tension lamination grading considerations being applied, the allowable bending property is obtained by multiplying the allowable property calculated in Sections 7 and 8 by 0.85 if the depth is 15 in. or less or by 0.75 if the depth exceeds 15 in.

10.1.1 The outer 10 % is further divided into two zones, the outer 5 % and the next inner 5 %.

10.1.2 The use of the equations in 10.2 for the outer 5 % zone is limited to tension laminations with *SR_{tl}* values of 0.5 to 0.82 because bending tests cited used tension laminations within that range.

10.2 Visually Graded Lumber:

10.2.1 For definitions of terms required for calculation of knot and grain deviation restrictions, see 3.2.

10.2.2 Knots and local grain deviations are expressed as a ratio of the cross-sectional area they occupy to the cross-sectional area of the lumber based on the dressed width of the lumber. They are measured using the displacement technique. Knots are measured to the lateral extremes of the knot; grain deviations (with or without knots) are measured to the lateral extremes of the zone within which the local slope of grain exceeds the allowable slope of grain for the grade. Eq 8-11 which follow, yield the maximum allowable knot and grain deviation ratios in the outer 10 % of depth. It is suggested these ratios be adjusted downward to the nearest 0.05 or to the next nearest convenient fraction (such as 1/3). Examples of knot and grain deviation restrictions for tension lamination grades are given in Table 10.

10.2.3 Beams Greater than 15 in. in Depth:

10.2.3.1 Outer 5 %—Grain deviation shall be limited in accordance with Eq 8 and 9.

TABLE 10 Examples of Knot and Knot Plus Grain Deviation Restrictions for Tension Lamination Grades

Strength Ratio ^A (<i>SR_{tl}</i>)	Outer 5 %		Next Inner 5 %	
	<i>GDE</i> ^B	<i>GDC</i> ^B	<i>KE</i> ^B	<i>KC</i> ^B
0.80	0.310	0.364	0.300	0.456
0.75	0.388	0.455	0.323	0.503
0.70	0.465	0.546	0.345	0.549
0.65	0.543	0.637	0.368	0.596
0.60	0.620	0.728	0.390	0.642
0.55	0.698	0.819	0.413	0.689
0.50	0.775	0.910	0.435	0.735

^A Tension lamination strength ratio at the outermost fiber.

^B See 3.2 for definitions of terms.

$$GDS \leq 1.55(1 - SR_{tl}) \tag{8}$$

$$GDS \leq 1.82(1 - SR_{tl}) \tag{9}$$

Use Eq 8 when *GDE*, with or without *GDC*, is used to determine *GDS* (see Fig. 1). Use Eq 9 when *GDE* is not used to determine *GDS*. In addition, general slope of grain shall not exceed 1:16 if the required strength ratio of the tension lamination is 0.60 or greater. If it is less than 0.60, the general slope of grain shall not exceed 1:12.

10.2.3.2 Next Inner 5 %—Knots are restricted in accordance with Eq 10 and 11.

$$KE = 0.66 - 0.45 SR_{tl} \tag{10}$$

$$KC = 1.20 - 0.93 SR_{tl} \tag{11}$$

General slope of grain shall be limited in accordance with the strength requirements of the individual laminations.

10.2.4 Beams 12 to 15 in. in Depth:

10.2.4.1 Outer 5 %—The requirements of 10.2.3.1 apply except that *SR_{tl}* shall be multiplied by 0.90 in Eq 8 and 9. The value of 0.9 *SR_{tl}* shall not be less than 0.50.

10.2.4.2 Next Inner 5 %—General slope of grain shall be limited in accordance with the strength requirements of the individual laminations.

10.2.5 Beams of four or more laminations and less than 12 in. in depth:

10.2.5.1 Outer 5 %—The requirements of 10.2.3.1 apply except that *SR_{tl}* shall be multiplied by 0.80 in Eq 8 and 9. The value of 0.80 *SR_{tl}* shall not be less than 0.50.

10.2.5.2 Next Inner 5 %—General slope of grain shall be limited in accordance with the strength requirements of the individual laminations.

10.2.6 Density Requirements:

10.2.6.1 Outer 5 %—Density requirements shall apply to the full length of the piece of lumber. In order to ensure that lumber is near-average or above specific gravity for the species, visually graded tension laminations shall have a minimum specific gravity of at least 94 % of the recognized species average from Test Methods D 2555 based on dry weight and volume at 12 % moisture content. The minimum specific gravity of the piece of lumber shall be the average specific gravity of the entire piece. Rate of growth and percentage of latewood requirements for tension laminations shall apply to the full length of lumber. Visual inspection alone is not an acceptable method of determining specific gravity.

10.2.7 Other Requirements:

10.2.7.1 *Outer 5 %*—Wide-ringed or lightweight pith associated wood has a pronounced effect on finger joint strength. The amount of material not meeting rate of growth and density requirements, in combination with compression wood, shall be limited to 1/8 of the cross section of the piece of lumber. In addition, for wet service conditions or pressure-treated members, compression wood is limited to a maximum of 5 % of the cross section.

10.2.7.2 *Next Inner 5 %*—There are no special requirements.

10.3 *E-rated Lumber:*

10.3.1 *Grading Requirements:*

10.3.1.1 *Outer 5 %*—In addition to having the required modulus of elasticity, *E-rated* lumber must meet the requirements for visually graded lumber given in 10.2.2, 10.2.3.1, and 10.2.4.1, with the exception of the knot and slope of grain requirements as given in 10.3.3.

10.3.1.2 *Next Inner 5 %*—There are no special requirements.

10.3.2 *Other Requirements:*

10.3.2.1 *Outer 5 %*—Wide-ringed or lightweight pith associated wood and compression wood are limited in the same manner as for visually graded lumber, except that there are no density requirements. Material not meeting medium grain rate of growth, in combination with compression wood, shall be

limited to 1/8 of the cross section of the piece of lumber. In addition, for wet conditions of use or pressure-treated members, compression wood is limited to a maximum of 5 % of the cross section.

10.3.2.2 *Next Inner 5 %*—There are no special requirements.

10.3.3 The portions of the piece not subjected to mechanical *E* measurements shall have visual criteria applied to ensure piece quality. Edge knots up to the size permitted in the grade are acceptable. Other knots are limited to the visual requirements of the bending stress index for which the *E-rated* lumber is qualified. For tension laminations, the slope of grain shall not exceed 1:12 and wide-ringed or pith-associated wood and compression wood is limited as in 10.3.2. Medium grain growth requirements shall be met for Douglas Fir-Larch and Southern Pine material.

10.4 Tension laminations to meet the requirements identified in 10.1 may be qualified by test as an alternative to the grading criteria of 10.2 and 10.3. The procedure given in Annex A1 shall be used.

11. Keywords

11.1 clear wood; glulam; lumber; structural glued laminated timber; timber

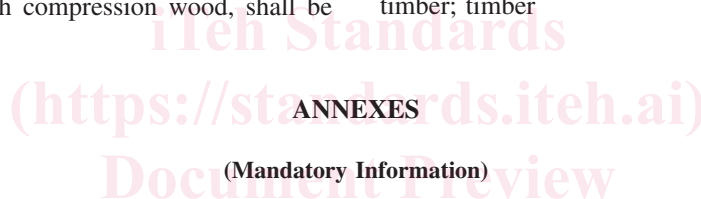

ANNEXES

(Mandatory Information)

A1. QUALIFICATION OF LAMINATIONS BY TEST

A1.1 If lumber is to be qualified by test as equivalent to visually graded or *E-rated* laminations, procedures in this section shall be followed. Tests shall include long span *E*, tensile strength, and specific gravity. Values for compression perpendicular to the grain and horizontal shear shall be determined following procedures previously described in this standard.

A1.1.1 Qualification shall be carried out on the size and grade of product for which qualification is desired, except that qualification at a specified width will satisfy qualification requirements for the next smallest width.

A1.1.1.1 If qualification of a width by test is used to qualify the next smaller width, selection criteria for the grade of both widths must be identical.

NOTE A1.1—As an example, qualification of a 2.0*E*, 1/8 edge knot grade in nominal 2 by 6 for a tension lamination target will qualify the same grade in 2 by 4 if the same *E* selection levels and edge knot selection criteria are used.

A1.1.1.2 Principles of Practice D 2915 shall be followed in sampling. A sample of 50 or more is required for *E* measurements; a minimum of 58 is required for tensile strength.

A1.2 Qualification by test shall include a flatwise bending modulus of elasticity on a 100:1 span-to-depth ratio (see 3.1.5.2).

A1.2.1 Qualification tests for *LSE* shall be carried out in accordance with Test Methods D 198 or D 4761.

A1.2.2 To qualify by *E* criterion, the average *LSE* (*E*) of the sample shall meet the following criteria:

$$(E) [(1 + (0.237) (COV))] \geq E_o \quad (A1.1)$$

where:

COV = coefficient of variation of *E* in the candidate stock, and

*E*_o = average *LSE* of the target grade for which replacement is sought.

NOTE A1.2—For example, assume the target grade is 302-24 from *D*. Fir L with an *LSE* of 2.1×10^6 psi. The candidate stock is *MSR* lumber. The *COV* of the qualification sample does not exceed 0.11 as given in the NDS (12). The product of *LSE* of the candidate sample and 1.026 must equal or exceed 2.1. As a second example, assume the target grade is 302-24 from Hem-Fir SSS with an *LSE* of 1.8×10^6 psi. The candidate stock is visually graded; the National Design Specification (NDS) *COV* for visually graded lumber is 0.25. The product of *LSE* of the candidate stock and 1.059 must equal or exceed 1.8.

A1.3 Qualification shall include a strength test of full-size laminations in tension.

A1.3.1 Tensile testing procedures shall follow the principles of Test Methods D 198 or D 4761 with a minimum gage length of 8 ft.