

---

---

**Metallic materials — Vickers hardness  
test —**

**Part 1:  
Test method**

*Matériaux métalliques — Essai de dureté Vickers —  
Partie 1: Méthode d'essai*  
**iTeh STANDARD PREVIEW  
(standards.iteh.ai)**

ISO 6507-1:2005

<https://standards.iteh.ai/catalog/standards/sist/1462e228-6141-4758-945e-debbd84a3980/iso-6507-1-2005>



**PDF disclaimer**

This PDF file may contain embedded typefaces. In accordance with Adobe's licensing policy, this file may be printed or viewed but shall not be edited unless the typefaces which are embedded are licensed to and installed on the computer performing the editing. In downloading this file, parties accept therein the responsibility of not infringing Adobe's licensing policy. The ISO Central Secretariat accepts no liability in this area.

Adobe is a trademark of Adobe Systems Incorporated.

Details of the software products used to create this PDF file can be found in the General Info relative to the file; the PDF-creation parameters were optimized for printing. Every care has been taken to ensure that the file is suitable for use by ISO member bodies. In the unlikely event that a problem relating to it is found, please inform the Central Secretariat at the address given below.

**iTeh STANDARD PREVIEW**  
**(standards.iteh.ai)**

ISO 6507-1:2005

<https://standards.iteh.ai/catalog/standards/sist/1462e228-6141-4758-945e-debbd84a3980/iso-6507-1-2005>

© ISO 2005

All rights reserved. Unless otherwise specified, no part of this publication may be reproduced or utilized in any form or by any means, electronic or mechanical, including photocopying and microfilm, without permission in writing from either ISO at the address below or ISO's member body in the country of the requester.

ISO copyright office  
Case postale 56 • CH-1211 Geneva 20  
Tel. + 41 22 749 01 11  
Fax + 41 22 749 09 47  
E-mail [copyright@iso.org](mailto:copyright@iso.org)  
Web [www.iso.org](http://www.iso.org)

Published in Switzerland

## Contents

Page

Foreword.....	iv
Introduction .....	v
1 Scope .....	1
2 Normative references .....	1
3 Principle .....	2
4 Symbols and abbreviated terms .....	2
5 Testing machine.....	3
6 Test piece .....	3
7 Procedure .....	3
8 Uncertainty of the results .....	5
9 Test report .....	5
Annex A (normative) Minimum thickness of the test piece in relation to the test force and to the hardness .....	6
Annex B (normative) Tables of correction factors for use in tests made on curved surfaces .....	8
Annex C (informative) Procedure for periodic checking of the testing machine by the user .....	12
Annex D (informative) Uncertainty of the measured hardness values .....	13
Bibliography .....	19

## Foreword

ISO (the International Organization for Standardization) is a worldwide federation of national standards bodies (ISO member bodies). The work of preparing International Standards is normally carried out through ISO technical committees. Each member body interested in a subject for which a technical committee has been established has the right to be represented on that committee. International organizations, governmental and non-governmental, in liaison with ISO, also take part in the work. ISO collaborates closely with the International Electrotechnical Commission (IEC) on all matters of electrotechnical standardization.

International Standards are drafted in accordance with the rules given in the ISO/IEC Directives, Part 2.

The main task of technical committees is to prepare International Standards. Draft International Standards adopted by the technical committees are circulated to the member bodies for voting. Publication as an International Standard requires approval by at least 75 % of the member bodies casting a vote.

Attention is drawn to the possibility that some of the elements of this document may be the subject of patent rights. ISO shall not be held responsible for identifying any or all such patent rights.

ISO 6507-1 was prepared by Technical Committee ISO/TC 164, *Mechanical testing of metals*, Subcommittee SC 3, *Hardness testing*.

This third edition, together with ISO 6507-4, cancels and replaces the second edition (ISO 6507-1:1997) which has been technically revised.

ISO 6507 consists of the following parts, under the general title *Metallic materials — Vickers hardness test*:

- *Part 1: Test method* <https://standards.iteh.ai/catalog/standards/sist/1462e228-6141-4758-945e-debbd84a3980/iso-6507-1-2005>
- *Part 2: Verification and calibration of testing machines*
- *Part 3: Calibration of reference blocks*
- *Part 4: Tables of hardness values*

## Introduction

The periodic checking of the testing machine described in informative Annex C is good metrological practice. It is intended to make the annex normative in the next revision of this part of ISO 6507 Standard.

For automated measuring systems this standard should be applied accordingly.

## iTeh STANDARD PREVIEW (standards.iteh.ai)

ISO 6507-1:2005

<https://standards.iteh.ai/catalog/standards/sist/1462e228-6141-4758-945e-debbd84a3980/iso-6507-1-2005>

**iTeh STANDARD PREVIEW**  
**(standards.iteh.ai)**

ISO 6507-1:2005

<https://standards.iteh.ai/catalog/standards/sist/1462e228-6141-4758-945e-debbd84a3980/iso-6507-1-2005>

# Metallic materials — Vickers hardness test —

## Part 1: Test method

### 1 Scope

This part of ISO 6507 specifies the Vickers hardness test method, for the three different ranges of test force for metallic materials (see Table 1).

Table 1 — Ranges of test force

Ranges of test force, $F$ N	Hardness symbol	Designation
$F \geq 49,03$	$\geq$ HV 5	Vickers hardness test
$1,961 \leq F < 49,03$	HV 0,2 to $<$ HV 5	Low-force Vickers hardness test
$0,098\ 07 \leq F < 1,961$	HV 0,01 to $<$ HV 0,2	Vickers microhardness test

ISO 6507-1:2005

<https://standards.iteh.ai/catalog/standards/sist/1462e228-6141-4758-945e->

The Vickers hardness test is specified in this part of ISO 6507 for lengths of indentation diagonals between 0,020 mm and 1,400 mm.

NOTE 1 For indentation diagonals less than 0,020 mm, the increase of the uncertainty has to be considered.

NOTE 2 In general, decreasing the test force increases the scatter of results of the measurements. This is particularly true for low-force Vickers hardness tests and Vickers microhardness tests, where the principal limitation will arise in the measurement of the diagonals of the indentation. For Vickers microhardness, the accuracy of determination of the mean diagonal length is unlikely to be better than  $\pm 0,001$  mm (see Bibliography [2]-[5]).

For specific materials and/or products, particular International Standards exist.

### 2 Normative references

The following referenced documents are indispensable for the application of this document. For dated references, only the edition cited applies. For undated references, the latest edition of the referenced document (including any amendments) applies.

ISO 6507-2:2005, *Metallic materials — Vickers hardness test — Part 2: Verification and calibration of testing machines*

ISO 6507-4, *Metallic materials — Vickers hardness test — Part 4: Tables of hardness values*

### 3 Principle

A diamond indenter, in the form of a right pyramid with a square base and with a specified angle between opposite faces at the vertex, is forced into the surface of a test piece followed by measurement of the diagonal length of the indentation left in the surface after removal of the test force,  $F$  (see Figure 1).

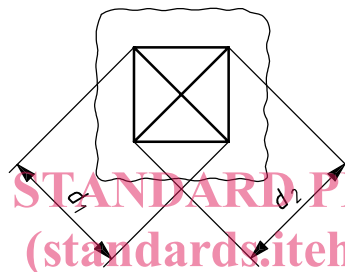
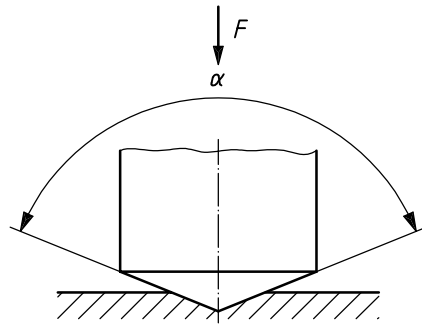

**Figure 1 — Principle of the test**  
<https://standards.itih.ai/catalog/standards/sist/1462e228-6141-4758-945e-debbd84a3980/iso-6507-1-2005>

The Vickers hardness is proportional to the quotient obtained by dividing the test force by the sloping area of the indentation, which is assumed to be a right pyramid with a square base, and having at the vertex the same angle as the indenter.

### 4 Symbols and abbreviated terms

4.1 See Table 2 and Figure 1.

**Table 2 — Symbols and abbreviated terms**

Symbol/ Abbreviated term	Designation
$\alpha$	Angle between the opposite faces at the vertex of the pyramidal indenter (136°)
$F$	Test force, in newtons (N)
$d$	Arithmetic mean, in millimetres, of the two diagonal lengths $d_1$ and $d_2$ (see Figure 1)
HV	Vickers hardness = Constant $\times$ $\frac{\text{Test force}}{\text{Surface area of indentation}} = 0,102 \frac{2 F \sin \frac{136^\circ}{2}}{d^2} \approx 0,189 1 \frac{F}{d^2}$
NOTE	Constant = 0,102 $\approx$ 1/9,806 65, where 9,806 65 is the conversion factor from kgf to N.



**4.2** The following is an example of the designation of Vickers hardness HV.

EXAMPLE

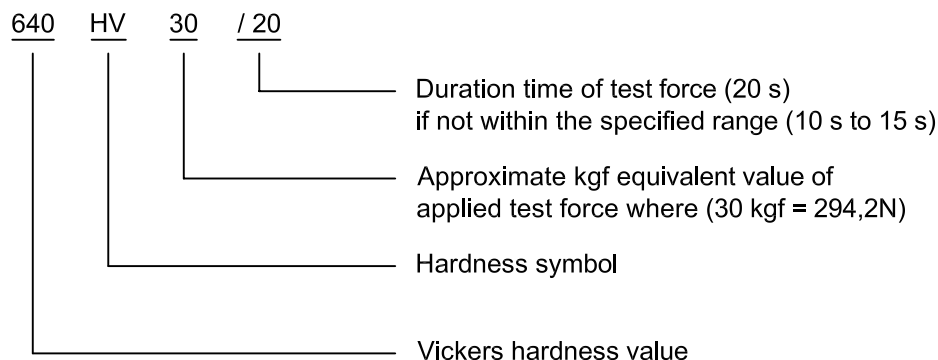

## 5 Testing machine

**5.1 Testing machine**, capable of applying a predetermined force or forces within the required range of test forces, in accordance with ISO 6507-2.

**5.2 Indenter**, a diamond in the shape of a right pyramid with a square base, as specified in ISO 6507-2.

**5.3 Measuring system**, as specified in ISO 6507-2.

NOTE A suggested procedure for periodic checks of the hardness testing machine by the users is given in Annex C.

## 6 Test piece

**6.1** The test shall be carried out on a surface which is smooth and even, free from oxide scale, foreign matter and, in particular, completely free from lubricants, unless otherwise specified in product standards. The finish of the surface shall permit accurate determination of the diagonal length of the indentation.

**6.2** Preparation shall be carried out in such a way that any alteration of the surface hardness, due to excessive heating or cold-working, for example, is minimized.

Due to the small depth of Vickers microhardness indentations, it is essential that special precautions are taken during preparation. It is recommended to use a polishing/electropolishing process which is suitable for the material parameters.

**6.3** The thickness of the test piece, or of the layer under test, shall be at least 1,5 times the diagonal length of the indentation (see Annex A).

No deformation shall be visible at the back of the test piece after the test.

**6.4** For tests on curved surfaces, the corrections given in Annex B, Tables B.1 to B.6 shall be applied.

**6.5** For test pieces of small cross-section or of irregular shape, it may be necessary to provide some form of additional support.

## 7 Procedure

**7.1** In general, the test is carried out at ambient temperature within the limits of 10 °C to 35 °C. Tests carried out under controlled conditions shall be made at a temperature of (23 ± 5) °C.

**7.2** The test forces given in Table 3 are recommended.

NOTE Other values e.g. HV 2,5 (24,52 N) may be used.

Table 3 — Test forces

Hardness test <sup>a</sup>		Low-force hardness test		Microhardness test	
Hardness symbol	Nominal value of the test force <i>F</i> N	Hardness symbol	Nominal value of the test force <i>F</i> N	Hardness symbol	Nominal value of the test force <i>F</i> N
HV 5	49,03	HV 0,2	1,961	HV 0,01	0,098 07
HV 10	98,07	HV 0,3	2,942	HV 0,015	0,147
HV 20	196,1	HV 0,5	4,903	HV 0,02	0,196 1
HV 30	294,2	HV 1	9,807	HV 0,025	0,245 2
HV 50	490,3	HV 2	19,61	HV 0,05	0,490 3
HV 100	980,7	HV 3	29,42	HV 0,1	0,980 7

<sup>a</sup> Nominal test forces greater than 980,7 N may be applied.

7.3 The test piece shall be placed on a rigid support. The support surfaces shall be clean and free from foreign matter (scale, oil, dirt, etc.). It is important that the test piece lies firmly on the support so that displacement cannot occur during the test.

7.4 Bring the indenter into contact with the test surface and apply the test force in a direction perpendicular to the surface, without shock or vibration, until the applied force attains the specified value. The time from the initial application of the force until the full test force is reached shall not be less than 2 s nor greater than 8 s. For low-force hardness and microhardness tests, the maximum time shall not exceed 10 s. For low-force hardness and microhardness tests, the approach speed of the indenter shall not exceed 0,2 mm/s.

For micro-hardness tests, the indenter should contact the test piece at a velocity between 15 µm/s and 70 µm/s.

The duration of the test force shall be 10 s to 15 s, except for tests on materials whose time-dependent properties would make this an unsuitable range. For these tests, a longer duration is permitted and this duration shall be specified as part of the hardness designation (see EXAMPLE in 4.2).

7.5 Throughout the test, the testing machine shall be protected from shock or vibration.

7.6 The distance between the centre of any indentation and the edge of the test piece shall be at least 2,5 times the mean diagonal length of the indentation in the case of steel, copper and copper alloys, and at least three times the mean diagonal length of the indentation in the case of light metals, lead and tin and their alloys.

The distance between the centres of two adjacent indentations shall be at least three times the mean diagonal length of the indentation in the case of steel, copper and copper alloys, and at least six times the mean diagonal length in the case of light metals, lead and tin and their alloys. If two adjacent indentations differ in size, the spacing shall be based on the mean diagonal length of the larger indentation.

7.7 Measure the lengths of the two diagonals. The arithmetical mean of the two readings shall be taken for the calculation of the Vickers hardness.

For flat surfaces, the difference between the lengths of two indentation diagonals should not be greater than 5 %. If the difference is greater, this shall be stated in the test report.

Magnifications should be provided so that the diagonal can be enlarged to greater than 25 %, but less than 75 % of the field of view.

7.8 ISO 6507-4 contains calculation tables which shall be used to determine the Vickers hardness for tests on flat surfaces.

## 8 Uncertainty of the results

A complete evaluation of the uncertainty should be done according to the ISO *Guide to the expression of uncertainty in measurement* (GUM) [6].

Independent of the type of sources, for hardness there are two possibilities for the determination of the uncertainty.

- One possibility is based on the evaluation of all relevant sources appearing during a direct calibration. As a reference, an EA guideline [7] is available.
- The other possibility is based on indirect calibration using a hardness reference block [below abbreviated as CRM (certified reference material)] (see [7-10] in the Bibliography). A guideline for the determination is given in Annex D.

It may not always be possible to quantify all the identified contributions to the uncertainty. In this case, an estimate of type A standard uncertainty may be obtained from the statistical analysis of repeated indentations into the test piece. Care should be taken, if standard uncertainties of type A and B are summarised, that the contributions are not counted twice (see Clause 4 of GUM:1993).

## 9 Test report

The test report shall include the following information:

- a) a reference to this part of ISO 6507;
- b) all details necessary for identification of the test piece;
- c) the result obtained; <https://standards.iteh.ai/catalog/standards/sist/1462e228-6141-4758-945e-d6bb484e2980/iso-6507-1-2005>
- d) all operations not specified in this part of ISO 6507, or regarded as optional;
- e) details of any occurrence which may have affected the results;
- f) the temperature of the test, if it is outside the range specified in 7.1.

NOTE 1 A strict comparison of hardness values is only possible at identical test forces.

There is no general process of accurately converting Vickers hardness into other scales of hardness or into tensile strength. Such conversions, therefore, should be avoided, unless a reliable basis for conversion can be obtained by comparison tests.

It should be noted that for anisotropic materials, for example those which have been heavily cold-worked, there will be a difference between the lengths of the two diagonals of the indentation. Where possible, the indentation should be made so that the diagonals are inclined at approximately 45° to the direction of cold-working. The specification for the product may indicate limits for the differences between the lengths of the two diagonals.

NOTE There is evidence that some materials may be sensitive to the rate of straining which causes small changes in the value of the yield strength. The corresponding effect on the termination of the formation of an indentation can make alterations in the hardness value.