



# Standard Test Method for Determination of Total Sulfur in Light Hydrocarbons, Spark Ignition Engine Fuel, Diesel Engine Fuel, and Engine Oil by Ultraviolet Fluorescence<sup>1</sup>

This standard is issued under the fixed designation D 5453; the number immediately following the designation indicates the year of original adoption or, in the case of revision, the year of last revision. A number in parentheses indicates the year of last reapproval. A superscript epsilon ( $\epsilon$ ) indicates an editorial change since the last revision or reapproval.

## 1. Scope\*

1.1 This test method covers the determination of total sulfur in liquid hydrocarbons, boiling in the range from approximately 25 to 400°C, with viscosities between approximately 0.2 and 20 cSt ( $\text{mm}^2/\text{S}$ ) at room temperature.

1.2 Three separate interlaboratory studies (ILS) on precision, and two other investigations that resulted in an ASTM research report, have determined that this test method is applicable to naphthas, distillates, engine oil, ethanol, Fatty Acid Methyl Ester (FAME), and engine fuel such as gasoline, oxygen enriched gasoline (M-85, RFG), diesel, biodiesel, and jet fuel. Samples containing 1.0 to 8000 mg/kg total sulfur can be analyzed (Note 1).

NOTE 1—Estimates of the pooled limit of quantification (PLOQ) for each of the five precision studies were calculated. Values ranged between less than 1.0 and less than 5.0 mg/kg (see Section 8 and 15.1).

1.3 This test method is applicable for total sulfur determination in liquid hydrocarbons containing less than 0.35 % (m/m) halogen(s).

1.4 The values stated in SI units are to be regarded as standard.

1.5 *This standard does not purport to address all of the safety concerns, if any, associated with its use. It is the responsibility of the user of this standard to establish appropriate safety and health practices and determine the applicability of regulatory limitations prior to use.* For warning statements, see 3.1, 6.3, 6.4, Section 7, and 8.1.

## 2. Referenced Documents

### 2.1 ASTM Standards:<sup>2</sup>

<sup>1</sup> This test method is under the jurisdiction of ASTM Committee D02 on Petroleum Products and Lubricants and is the direct responsibility of Subcommittee D02.03 on Elemental Analysis.

Current edition approved Nov. 1, 2004. Published November 2004. Originally approved in 1993. Last previous edition approved in 2003 as D 5453–03a.

<sup>2</sup> For referenced ASTM standards, visit the ASTM website, www.astm.org, or contact ASTM Customer Service at service@astm.org. For *Annual Book of ASTM Standards* volume information, refer to the standard's Document Summary page on the ASTM website.

- D 1298 Test Method for Density, Relative Density (Specific Gravity), or API Gravity of Crude Petroleum and Liquid Petroleum Products by Hydrometer Method
- D 4052 Test Method for Density and Relative Density of Liquids by Digital Density Meter
- D 4057 Practice for Manual Sampling of Petroleum and Petroleum Products
- D 4177 Practice for Automatic Sampling of Petroleum and Petroleum Products
- D 6299 Practice for Applying Statistical Quality Assurance Techniques to Evaluate Analytical Measurement System Performance

## 3. Summary of Test Method

3.1 A hydrocarbon sample is either directly injected or placed in a sample boat. The sample or boat, or both, is inserted into a high temperature combustion tube where the sulfur is oxidized to sulfur dioxide ( $\text{SO}_2$ ) in an oxygen rich atmosphere. Water produced during the sample combustion is removed and the sample combustion gases are next exposed to ultraviolet (UV) light. The  $\text{SO}_2$  absorbs the energy from the UV light and is converted to excited sulfur dioxide ( $\text{SO}_2^*$ ). The fluorescence emitted from the excited  $\text{SO}_2^*$  as it returns to a stable state,  $\text{SO}_2$ , is detected by a photomultiplier tube and the resulting signal is a measure of the sulfur contained in the sample. (**Warning**—Exposure to excessive quantities of ultraviolet (UV) light is injurious to health. The operator must avoid exposing any part of their person, especially their eyes, not only to direct UV light but also to secondary or scattered radiation that is present.)

## 4. Significance and Use

4.1 Some process catalysts used in petroleum and chemical refining can be poisoned when trace amounts of sulfur bearing materials are contained in the feedstocks. This test method can be used to determine sulfur in process feeds sulfur in finished products, and can also be used for purposes of regulatory control.

\*A Summary of Changes section appears at the end of this standard.

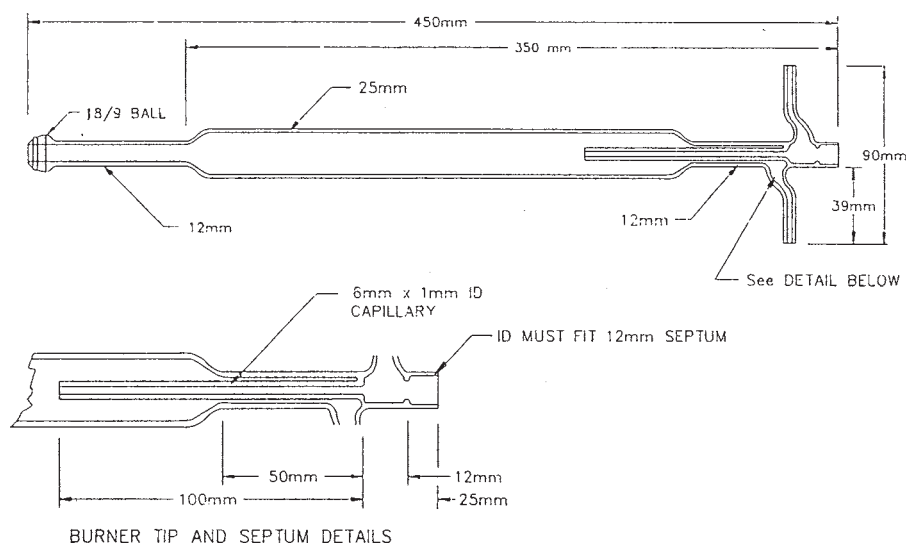

FIG. 1 Direct Inject Quartz Pyrolysis Tube

## 5. Apparatus

5.1 *Furnace*—An electric furnace held at a temperature ( $1075 \pm 25^\circ\text{C}$ ) sufficient to pyrolyze all of the sample and oxidize sulfur to  $\text{SO}_2$ .

5.2 *Combustion Tube*—A quartz combustion tube constructed to allow the direct injection of the sample into the heated oxidation zone of the furnace or constructed so that the inlet end of the tube is large enough to accommodate a quartz sample boat. The combustion tube must have side arms for the introduction of oxygen and carrier gas. The oxidation section shall be large enough (see Figs. 1 and 2) to ensure complete combustion of the sample. Figs. 1 and 2 depict conventional combustion tubes. Other configurations are acceptable if precision is not degraded.

5.3 *Flow Control*—The apparatus must be equipped with flow controllers capable of maintaining a constant supply of oxygen and carrier gas.

5.4 *Drier Tube*—The apparatus must be equipped with a mechanism for the removal of water vapor. The oxidation reaction produces water vapor which must be eliminated prior to measurement by the detector. This can be accomplished with a membrane drying tube, or a permeation dryer, that utilizes a selective capillary action for water removal.

5.5 *UV Fluorescence Detector*—A qualitative and quantitative detector capable of measuring light emitted from the fluorescence of sulfur dioxide by UV light.

5.6 *Microlitre Syringe*—A microlitre syringe capable of accurately delivering 5 to 20- $\mu\text{L}$  quantities. The needle shall be 50 mm ( $\pm 5$  mm) long.

5.7 *Sample Inlet System*—Either of two types of sample inlet systems can be used.

5.7.1 *Direct Injection*—A direct injection inlet system must be capable of allowing the quantitative delivery of the material to be analyzed into an inlet carrier stream which directs the sample into the oxidation zone at a controlled and repeatable rate. A syringe drive mechanism which discharges the sample from the microlitre syringe at a rate of approximately 1  $\mu\text{L/s}$  is required. For example, see Fig. 3.

5.7.2 *Boat Inlet System*—An extended combustion tube provides a seal to the inlet of the oxidation area and is swept by a carrier gas. The system provides an area to position the sample carrying mechanism (boat) at a retracted position removed from the furnace. The boat drive mechanism will fully insert the boat into the hottest section of the furnace inlet. The sample boats and combustion tube are constructed of quartz. The combustion tube provides a cooling jacket for the area in which the retracted boat rests awaiting sample introduction from a microlitre syringe. A drive mechanism which advances and withdraws the sample boat into and out of the furnace at a controlled and repeatable rate is required. For example, see Fig. 4.

5.8 *Refrigerated Circulator*—An adjustable apparatus capable of delivering a coolant material at a constant temperature as low as  $4^\circ\text{C}$  could be required when using the boat inlet injection method (optional).

5.9 *Strip Chart Recorder*, (optional).

5.10 *Balance*, with a precision of  $\pm 0.01$  mg (optional).

## 6. Reagents

6.1 *Purity of Reagents*—Reagent grade chemicals shall be used in tests. Unless otherwise indicated, it is intended that all reagents shall conform to the specifications of the Committee on Analytical Reagents of the American Chemical Society, where such specifications are available.<sup>3</sup> Other grades may be used, provided it is first ascertained that the reagent is of sufficiently high purity to permit its use without lessening the accuracy of the determination.

6.2 *Inert Gas*—Argon or helium only, high purity grade (that is, chromatography or zero grade), 99.998 % minimum purity, moisture 5 ppm w/w maximum.

<sup>3</sup> *Reagent Chemicals, American Chemical Society Specifications*, American Chemical Society, Washington, DC. For suggestions on the testing of reagents not listed by the American Chemical Society, see *Annual Standards for Laboratory Chemicals*, BDH Ltd., Poole, Dorset, U.K., and the *United States Pharmacopeia and National Formulary*, U.S. Pharmacopeial Convention, Inc. (USPC), Rockville, MD.

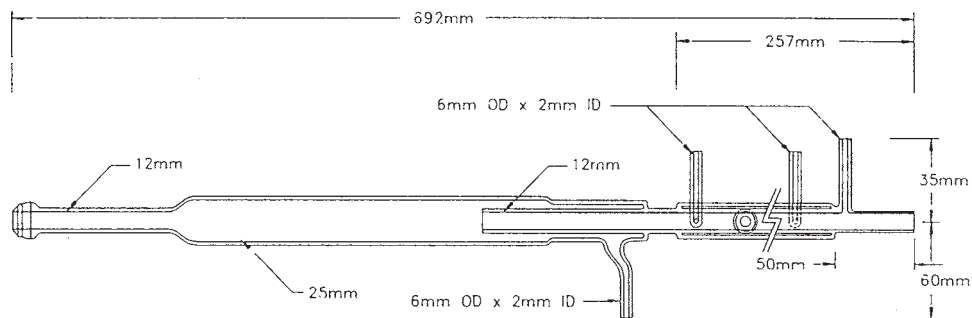

FIG. 2 Boat Inlet

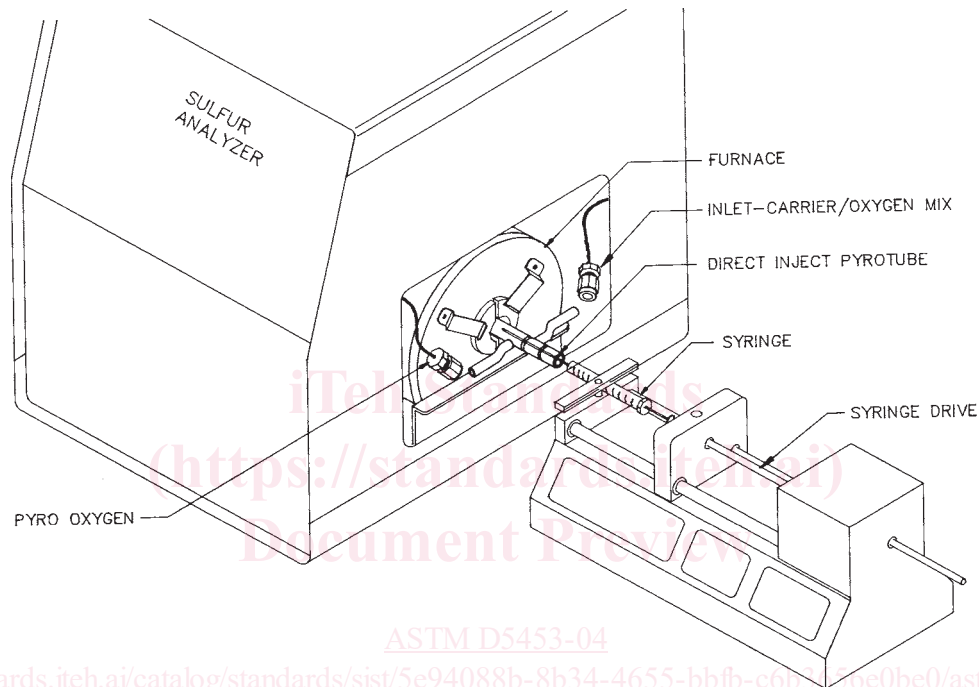

FIG. 3 Direct Inject Syringe Drive

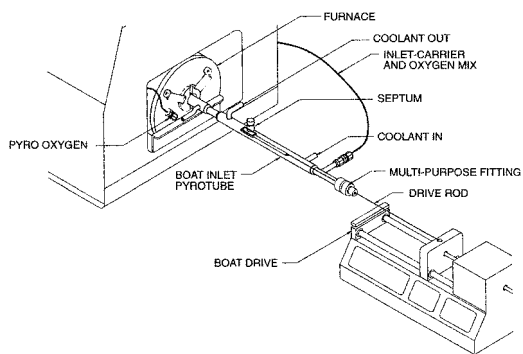

FIG. 4 Boat Inlet System

6.3 *Oxygen*—High purity (that is, chromatography or zero grade), 99.75 % minimum purity, moisture 5 ppm w/w maximum, dried over molecular sieves. (**Warning**—Vigorously accelerates combustion.)

6.4 *Toluene, Xylenes, Isooctane*, reagent grade (other solvents similar to those occurring in samples to be analyzed are also acceptable). Correction for sulfur contribution from solvents (solvent blank) used in standard preparation and sample

specimen dilution is required. Alternatively, use of a solvent with nondetectable level of sulfur contamination relative to the sulphur content in the sample unknown makes the blank correction unnecessary. (**Warning**—Flammable solvents.)

6.5 *Dibenzothiophene*, FW184.26, 17.399 % (m/m) S (**Note 2**).

6.6 *Butyl Sulfide*, FW146.29, 21.92 % (m/m) S (**Note 2**).

6.7 *Thionaphthene (Benzothiophene)*, FW134.20, 23.90 % (m/m) S (**Note 2**).

NOTE 2—A correction for chemical impurity can be required.

6.8 *Quartz Wool*.

6.9 *Sulfur Stock Solution, 1000 µg S/mL*—Prepare a stock solution by accurately weighing approximately 0.5748 g of dibenzothiophene or 0.4652 g of butyl sulfide or 0.4184 g of thionaphthene into a tared 100 mL volumetric flask. Dilute to volume with selected solvent. This stock can be further diluted to desired sulfur concentration (Notes 3-5).

NOTE 3—Working standards should be remixed on a regular basis depending upon frequency of use and age. Typically, stock solutions have a useful life of about 3 months.

**TABLE 1 Typical Operating Conditions**

Syringe drive (direct inject) drive rate (700–750)	1 $\mu\text{L/s}$
Boat drive (boat inlet) drive rate (700–750)	140–160 mm/min
Furnace temperature	1075 $\pm$ 25°C
Furnace oxygen flowmeter setting (3.8–4.1)	450–500 mL/min
Inlet oxygen flowmeter setting (0.4–0.8)	10–30 mL/min
Inlet carrier flowmeter setting (3.4–3.6)	130–160 mL/min

NOTE 4—Calibration standards can be prepared and diluted on a mass/mass basis when result calculations are adjusted to accommodate them.

NOTE 5—Calibration standards from commercial sources can be used if checked for accuracy and if precision is not degraded.

6.10 *Quality Control (QC) Samples*, preferably are portions of one or more liquid petroleum materials that are stable and representative of the samples of interest. These QC samples can be used to check the validity of the testing process as described in Section 14.

## 7. Hazards

7.1 High temperature is employed in this test method. Extra care must be exercised when using flammable materials near the oxidative pyrolysis furnace.

## 8. Sampling

8.1 Obtain a test unit in accordance with Practice D 4057 or Practice D 4177. To preserve volatile components which are in some samples, do not uncover samples any longer than necessary. Samples shall be analyzed as soon as possible after taking from bulk supplies to prevent loss of sulfur or contamination due to exposure or contact with sample container. (**Warning**—Samples that are collected at temperatures below room temperature can undergo expansion and rupture the container. For such samples, do not fill the container to the top; leave sufficient air space above the sample to allow room for expansion.)

8.2 If the test unit is not used immediately, then thoroughly mix in its container prior to taking a test specimen.

## 9. Preparation of Apparatus

9.1 Assemble and leak check apparatus according to manufacturer's instructions.

9.2 Adjust the apparatus, depending upon the method of sample introduction, to meet conditions described in Table 1.

9.3 Adjust the instrument sensitivity and baseline stability and perform instrument blanking procedures following manufacturer's guidelines.

## 10. Calibration and Standardization

10.1 Based on anticipated sulfur concentration, select one of the suggested curves outlined in Table 2. Carefully prepare a series of calibration standards accordingly. Make other volumetric dilutions of the stock solution to cover the various ranges of operation within these calibration curve guidelines. The number of standards used per curve can vary, if equivalent results are obtained.

10.2 Flush the microlitre syringe several times with the sample prior to analysis. If bubbles are present in the liquid column, flush the syringe and withdraw a new sample.

**TABLE 2 Sulfur Standards**

Curve I Sulfur, ng/ $\mu\text{L}$	Curve II Sulfur, ng/ $\mu\text{L}$	Curve III Sulfur, ng/ $\mu\text{L}$
0.50	5.00	100.00
1.00	25.00	500.00
2.50	50.00	1000.00
5.00	100.00	
10.00		
Injection Size 10–20 $\mu\text{L}$	Injection Size 5–10 $\mu\text{L}$	Injection Size 5 $\mu\text{L}$

10.3 A sample size recommended for the curve selected from Table 2 must be quantitatively measured prior to injection into the combustion tube or delivery into the sample boat for analysis (Note 6 and Note 7). There are two alternative techniques available.

NOTE 6—Injection of a constant or similar sample size for all materials analyzed in a selected operating range promotes consistent combustion conditions.

NOTE 7—Injection of 10  $\mu\text{L}$  of the 100 ng/ $\mu\text{L}$  standard would establish a calibration point equal to 1000 ng or 1.0  $\mu\text{g}$ .

10.3.1 The volumetric measurement of the injected material can be obtained by filling the syringe to the selected level. Retract the plunger so that air is aspirated and the lower liquid meniscus falls on the 10 % scale mark and record the volume of liquid in the syringe. After injection, again retract the plunger so that the lower liquid meniscus falls on the 10 % scale mark and record the volume of liquid in the syringe. The difference between the two volume readings is the volume of sample injected (Note 8).

NOTE 8—An automatic sampling and injection device can be used in place of the described manual injection procedure.

10.3.2 Fill the syringe as described in 10.3.1. Weigh the device before and after injection to determine the amount of sample injected. This procedure can provide greater accuracy than the volume delivery method, provided a balance with a precision of  $\pm 0.01$  mg is used.

10.4 Once the appropriate sample size has been measured into the microlitre syringe, promptly and quantitatively deliver the sample into the apparatus. Again, there are two alternative techniques available.

10.4.1 For direct injection, carefully insert the syringe into the inlet of the combustion tube and the syringe drive. Allow time for sample residues to be burned from the needle (Needle Blank). Once a stable baseline has reestablished, promptly start the analysis. Remove syringe once the apparatus has returned to a stable baseline.

10.4.2 For the boat inlet, quantitatively discharge the contents of the syringe into the boat containing quartz wool at a slow rate being careful to displace the last drop from the syringe needle. Remove the syringe and promptly start the analysis. The instrument baseline shall remain stable until the boat approaches the furnace and vaporization of the sample begins. Instrument baseline is to be reestablished before the boat has been completely withdrawn from the furnace (Note 9). Once the boat has reached its fully retracted position, allow at least 1 min for cooling before the next sample injection (Note 9).



NOTE 9—Slowing boat speed or briefly pausing the boat in the furnace can be necessary to ensure complete sample combustion. Direct injection can ease sample handling and improve sample combustion characteristics for materials containing very volatile sulfur compounds.

10.4.3 The level of boat cooling required and the onset of sulfur detection following sample injection are directly related to the volatility of the materials analyzed. For volatile materials, effective cooling of the sample boat prior to sample injection is essential. The use of a refrigerated circulator to minimize the vaporization of the sample until the boat begins approaching the furnace or an increased time for boat cooling can be required.

10.5 Calibrate the instrument using one of the following two techniques.

10.5.1 Perform measurements for the calibration standards and blank using one of the procedures described in 10.2-10.4. Measure the calibration standards and blank three times. Subtract the average response of the blank injections from each calibration standard response. Then determine the average integrated response of each concentration (see 6.4). Construct a curve plotting of the average integrated detector response (y-axis) versus micrograms of sulfur injected (x-axis) (Note 10). This curve shall be linear and system performance must be checked each day of use. See Section 14.

NOTE 10—Other calibration curve techniques can be used when accuracy and precision are not degraded.

10.5.2 If the apparatus features self calibration routine, measure the calibration standards and blank three times using one of the procedures described in 10.2-10.4. If blank correction is required and is not an available instrument option (see 6.4 or 10.5.1), calibrate the analyzer in accordance with manufacturer's instructions to yield results expressed as nanograms of sulfur (Note 10). This curve shall be linear and system performance must be checked with each day of use (see Section 14).

10.6 If analyzer calibration is performed using a different calibration curve than listed in Table 2, select an injection size based on the curve closest in concentration to the measured solution(s). Construct the calibration curve to yield values that can be used to report sulfur content on a mass/mass basis.

## 11. Procedure

11.1 Obtain a test specimen using the procedure described in Section 8. The sulfur concentration in the test specimen must be less than the concentration of the highest standard and greater than the concentration of the lowest standard used in the calibration. If required, a dilution can be performed on either a weight or volume basis.

11.1.1 *Gravimetric Dilution (mass/mass)*—Record the mass of the test specimen and the total mass of the test specimen and solvent.

11.1.2 *Volumetric Dilution (mass/volume)*—Record the mass of the test specimen and the total volume of the test specimen and solvent.

11.2 Measure the response for the test specimen solution using one of the procedures described in 10.2-10.4.

11.3 Inspect the combustion tube and other flow path components to verify complete oxidation of the test specimen.

11.3.1 *Direct Inject Systems*—Reduce the sample size or the rate of injection, or both, of the specimen into the furnace if coke or sooting is observed.

11.3.2 *Boat Inlet Systems*—Increase the residence time for the boat in the furnace if coke or soot is observed on the boat. Decrease the boat drive introduction rate or specimen sample size, or both, if coke or soot is observed on the exit end of the combustion tube.

11.3.3 *Cleaning and Recalibration*—Clean any coked or sooted parts per manufacturer's instructions. After any cleaning or adjustment, assemble and leak check the apparatus. Repeat instrument calibration prior to reanalysis of the test specimen.

11.4 To obtain one result, measure each test specimen solution three times and calculate the average detector responses.

11.5 Density values needed for calculations are to be measured using Test Methods D 1298, D 4052, or equivalent, at the temperature at which the sample was tested.

## 12. Calculation

12.1 For analyzers calibrated using a standard curve, calculate the sulfur content of the test specimen in parts per million (ppm) as follows:

$$\text{Sulfur, ppm } (\mu\text{g/g}) = \frac{(I - Y)}{S \times M \times K_g} \quad (1)$$

or,

$$\text{Sulfur, ppm } (\mu\text{g/g}) = \frac{(I - Y(1000))}{S \times V \times K_v} \quad (2)$$

where:

$D$  = density of test specimen solution, g/mL,

$I$  = average of integrated detector response for test specimen solution, counts,

$K_g$  = gravimetric dilution factor, mass of test specimen/mass of test specimen and solvent, g/g,

$K_v$  = volumetric dilution factor, mass of test specimen/volume of test specimen and solvent, g/mL,

$M$  = mass of test specimen solution injected, either measured directly or calculated from measured volume injected and density,  $V \times D$ , g,

$S$  = slope of standard curve, counts/ $\mu\text{g}$  S,

$V$  = volume of test specimen solution injected, either measured directly or calculated from measured mass injected and density,  $M/D$ ,  $\mu\text{L}$ , and

$Y$  = y-intercept of standard curve, counts,

1000 = factor to convert  $\mu\text{L}$  to mL.

12.2 For analyzers calibrated using self calibration routine with blank correction, calculate the sulfur in the test specimen in parts per million (ppm) as follows:

$$\text{Sulfur, ppm } (\mu\text{g/g}) = \frac{G \times 1000}{M \times K_g} \quad (3)$$

or,

$$\text{Sulfur, ppm } (\mu\text{g/g}) = \frac{G \times 1000}{V \times D} \quad (4)$$

where:

- $D$  = density of test specimen solution, mg/ $\mu$ L (neat injection), or concentration of solution, mg/ $\mu$ L (volumetric dilute injection),
- $K_g$  = gravimetric dilution factor, mass of test specimen/mass of test specimen and solvent, g/g,
- $M$  = mass of test specimen solution injected, either measured directly or calculated from measured volume injected and density,  $V \times D$ , mg,
- $V$  = volume of test specimen solution injected, either measured directly or calculated from measured mass injected and density,  $M/D$ ,  $\mu$ L,
- $G$  = sulfur found in test specimen,  $\mu$ g, and
- 1000 = factor to convert  $\mu$ g/mg to  $\mu$ g/g.

### 13. Report

13.1 For results equal to or greater than 10 mg/kg, report the sulfur result to the nearest mg/kg. For results less than 10 mg/kg, report the sulfur result to the nearest tenth of a mg/kg. State that the results were obtained according to Test Method D 5453.

### 14. Quality Control

14.1 Confirm the performance of the instrument or the test procedure by analyzing a quality control (QC) sample (6.10) after each calibration and at least each day of use thereafter (see 10.5).

14.1.1 When QC/Quality Assurance (QA) protocols are already established in the testing facility, these can be used when they confirm the reliability of the test result.

14.1.2 When there is no QC/QA protocol established in the testing facility, Appendix X1 can be used as the QC/QA system.

### 15. Precision and Bias

15.1 The test method was examined in five separate inter-laboratory studies.<sup>4,5</sup> The precision of the test method, as obtained by statistical analysis of test results, is as follows (Note 11).

NOTE 11—Volatile materials can cause a deterioration in precision when not handled with care (see Section 8 and 10.4).

15.1.1 *Repeatability*—The difference between two test results obtained by the same operator with the same apparatus under constant operating conditions on identical test material

<sup>4</sup> Supporting data have been filed at ASTM International Headquarters and may be obtained by requesting Research Reports RR:D02-1307 (1992) original with multiple matrices; RR:D02-1456 (1999) UVF/X-ray equivalence study; RR:D02-1465 (1997) gasoline and RFG only; and RR:D02-1475 (1998) low level gasoline, diesel, and biodiesel.

<sup>5</sup> Supporting data have been filed at ASTM International Headquarters and may be obtained by requesting Research Report RR:D02-1547 (2000-2001) involving 39 labs and 16 samples each of low level gasoline (1–100  $\mu$ g/g S) and diesel (5–40  $\mu$ g/g S) based on practical limits of quantitation (PLOQ) determined in the study.

**TABLE 3 Repeatability ( $r$ ) and Reproducibility ( $R$ )**

Concentration (mg/kg S)	$r$	$R$
1	0.2	0.6
5	0.6	1.9
10	1.0	3.3
50	3.4	10.9
100	5.7	18.3
400	16.0	51.9

would, in the long run, in the normal and correct operation of the test method, exceed the following values in only 1 case in 20, where  $x$  = the average of the two test results.

$$\text{Less than 400 mg/kg: } r = 0.1788 X^{(0.75)} \quad (5)$$

$$\text{Greater than 400 mg/kg: } r = 0.02902 X \quad (6)$$

15.1.1.1 Research Report RR:D02-1547 (2000-2001) results:<sup>5</sup>

$$\text{Gasoline: } r = 0.04356 (X + 14.844) \quad (7)$$

$$\text{Diesel: } r = 0.02777 (X + 28.158) \quad (8)$$

15.1.2 *Reproducibility*—The difference between two single and independent results obtained by different operators working in different laboratories on identical test material would, in the long run, in the normal and correct operation of the test method, exceed the following values in only 1 case in 20, where  $x$  = the average of the two test results.

$$\text{Less than 400 mg/kg: } R = 0.5797 X^{(0.75)} \quad (9)$$

$$\text{Greater than 400 mg/kg: } R = 0.1267 X \quad (10)$$

15.1.2.1 Research Report RR:D02-1547 (2000-2001) results:<sup>5</sup>

$$\text{Gasoline: } R = 0.3170 (X + 6.8847) \quad (11)$$

$$\text{Diesel: } R = 0.3659 (X + 2.1101) \quad (12)$$

15.2 *Bias*—The bias of this test method was determined in a 1992 research report,<sup>4</sup> by analysis of standard reference materials (SRMs) containing known levels of sulfur in hydrocarbon. This report indicated that the results obtained on the SRMs were within the repeatability of the test method.

15.2.1 Three National Institute of Standards and Technology (NIST) Standard Reference Materials (SRM) were analyzed to determine the bias. These samples were gasoline SRMs 2298 (4.6  $\mu$ g/g S) and 2299 (13.6  $\mu$ g/g S), and diesel SRM 2723a (10  $\mu$ g/g S). There was no significant bias for the diesel SRM, but there was a bias of -0.97 and -2.00 for gasoline SRMs 2298 and 2299, respectively.<sup>5</sup>

15.3 Examples of the above precision estimates for samples containing less than 400 mg/kg are shown in Table 3.

### 16. Keywords

16.1 analysis; diesel; fluorescence; gasoline; jet fuel; kerosene; M-85; RFG; sulfur; ultraviolet