



**SLOVENSKI STANDARD**  
**SIST ISO 3245:2008**

01-julij-2008

BUXca Yý U  
SIST ISO 3245:2001

---

Rolling bearings - Needle roller bearings, drawn cup without inner ring - Boundary dimensions and tolerances

Rolling bearings - Needle roller bearings, drawn cup without inner ring - Boundary dimensions and tolerances

Nadellager - Nadelhülsen, Nadelbüchsen - Maße und Toleranzen

(standards.iteh.ai)

Roulements - Douilles à aiguilles sans bague intérieure - Dimensions d'encombrement et tolérances

[SIST ISO 3245:2008](#)

<https://standards.iteh.ai/catalog/standards/sist/d791dfd6-a2ec-4129-9df5-e5de1f7a9054/sist-iso-3245-2008>

Ta slovenski standard je istoveten z: **ISO 3245:2007**

---

**ICS:**

21.100.20      Kotalni ležaji      Rolling bearings

**SIST ISO 3245:2008**      en,fr

**iTeh STANDARD PREVIEW**  
**(standards.iteh.ai)**

SIST ISO 3245:2008

<https://standards.iteh.ai/catalog/standards/sist/d791dfd6-a2ec-4129-9df5-e5de1f7a9054/sist-iso-3245-2008>

---

---

**Rolling bearings — Needle roller  
bearings, drawn cup without inner ring —  
Boundary dimensions and tolerances**

*Roulements — Douilles à aiguilles sans bague intérieure — Dimensions  
d'encombrement et tolérances*

**iTeh STANDARD PREVIEW**  
**(standards.iteh.ai)**

[SIST ISO 3245:2008](https://standards.iteh.ai/catalog/standards/sist/d791dfd6-a2ec-4129-9df5-e5de1f7a9054/sist-iso-3245-2008)

[https://standards.iteh.ai/catalog/standards/sist/d791dfd6-a2ec-4129-9df5-  
e5de1f7a9054/sist-iso-3245-2008](https://standards.iteh.ai/catalog/standards/sist/d791dfd6-a2ec-4129-9df5-e5de1f7a9054/sist-iso-3245-2008)



**PDF disclaimer**

This PDF file may contain embedded typefaces. In accordance with Adobe's licensing policy, this file may be printed or viewed but shall not be edited unless the typefaces which are embedded are licensed to and installed on the computer performing the editing. In downloading this file, parties accept therein the responsibility of not infringing Adobe's licensing policy. The ISO Central Secretariat accepts no liability in this area.

Adobe is a trademark of Adobe Systems Incorporated.

Details of the software products used to create this PDF file can be found in the General Info relative to the file; the PDF-creation parameters were optimized for printing. Every care has been taken to ensure that the file is suitable for use by ISO member bodies. In the unlikely event that a problem relating to it is found, please inform the Central Secretariat at the address given below.

**iTeh STANDARD PREVIEW**  
**(standards.iteh.ai)**

SIST ISO 3245:2008

<https://standards.iteh.ai/catalog/standards/sist/d791dfd6-a2ec-4129-9df5-e5de1f7a9054/sist-iso-3245-2008>



**COPYRIGHT PROTECTED DOCUMENT**

© ISO 2007

All rights reserved. Unless otherwise specified, no part of this publication may be reproduced or utilized in any form or by any means, electronic or mechanical, including photocopying and microfilm, without permission in writing from either ISO at the address below or ISO's member body in the country of the requester.

ISO copyright office  
Case postale 56 • CH-1211 Geneva 20  
Tel. + 41 22 749 01 11  
Fax + 41 22 749 09 47  
E-mail [copyright@iso.org](mailto:copyright@iso.org)  
Web [www.iso.org](http://www.iso.org)

Published in Switzerland

## Foreword

ISO (the International Organization for Standardization) is a worldwide federation of national standards bodies (ISO member bodies). The work of preparing International Standards is normally carried out through ISO technical committees. Each member body interested in a subject for which a technical committee has been established has the right to be represented on that committee. International organizations, governmental and non-governmental, in liaison with ISO, also take part in the work. ISO collaborates closely with the International Electrotechnical Commission (IEC) on all matters of electrotechnical standardization.

International Standards are drafted in accordance with the rules given in the ISO/IEC Directives, Part 2.

The main task of technical committees is to prepare International Standards. Draft International Standards adopted by the technical committees are circulated to the member bodies for voting. Publication as an International Standard requires approval by at least 75 % of the member bodies casting a vote.

Attention is drawn to the possibility that some of the elements of this document may be the subject of patent rights. ISO shall not be held responsible for identifying any or all such patent rights.

ISO 3245 was prepared by Technical Committee ISO/TC 4, *Rolling bearings*, Subcommittee SC 5, *Needle roller bearings*.

This third edition cancels and replaces the second edition (ISO 3245:1997), which has been technically revised.

**iTeh STANDARD PREVIEW**  
**(standards.iteh.ai)**

SIST ISO 3245:2008

<https://standards.iteh.ai/catalog/standards/sist/d791dfd6-a2ec-4129-9df5-e5de1f7a9054/sist-iso-3245-2008>

**iTeh STANDARD PREVIEW**  
**(standards.iteh.ai)**

SIST ISO 3245:2008

<https://standards.iteh.ai/catalog/standards/sist/d791dfd6-a2ec-4129-9df5-e5de1f7a9054/sist-iso-3245-2008>

# Rolling bearings — Needle roller bearings, drawn cup without inner ring — Boundary dimensions and tolerances

## 1 Scope

This International Standard specifies the boundary dimensions and preferred dimensions to be used for drawn cup needle roller bearings without inner ring as well as the minimum chamfer dimension limits. Also specified are the closed end thickness dimensions for bearings with closed end drawn cups.

In addition, dimensional tolerances and methods for checking the needle roller complement bore diameter are specified.

## 2 Normative references

The following referenced documents are indispensable for the application of this document. For dated references, only the edition cited applies. For undated references, the latest edition of the referenced document (including any amendments) applies.

ISO 286-2:1988, *ISO system of limits and fits — Part 2: Tables of standard tolerance grades and limit deviations for holes and shafts*

ISO 1132-1, *Rolling bearings — Tolerances — Part 1: Terms and definitions*  
<https://standards.iteh.ai/catalog/standards/sist/d79fd66-azcc-4129-9df5-e5de1f7a9054/sist-iso-3245-2008>

ISO 1132-2:2001, *Rolling bearings — Tolerances — Part 2: Measuring and gauging principles and methods*

ISO 5593, *Rolling bearings — Vocabulary*

ISO 10579, *Technical drawing — Dimensioning and tolerancing — Non-rigid parts*

ISO 15241, *Rolling bearings — Symbols for quantities*

## 3 Terms and definitions

For the purposes of this document, the terms and definitions given in ISO 1132-1 and ISO 5593 apply.

## 4 Symbols

For the purposes of this document, the symbols given in ISO 15241 and the following apply.

The symbols (except those for tolerances) shown in Figure 1, and the values given in Tables 1 to 4 denote nominal dimensions unless otherwise specified.

$C$	drawn cup width
$C_1$	end thickness of profiled end drawn cup
$C_2$	end thickness of flat end drawn cup

- $D$  drawn cup outside diameter
- $F_w$  bore diameter of needle roller complement
- $F_{ws\ min}$  smallest single bore diameter of needle roller complement <sup>1)</sup>
- $r$  chamfer dimension
- $r_{s\ min}$  smallest single chamfer dimension
- $\Delta_{Cs}$  deviation of single drawn cup width

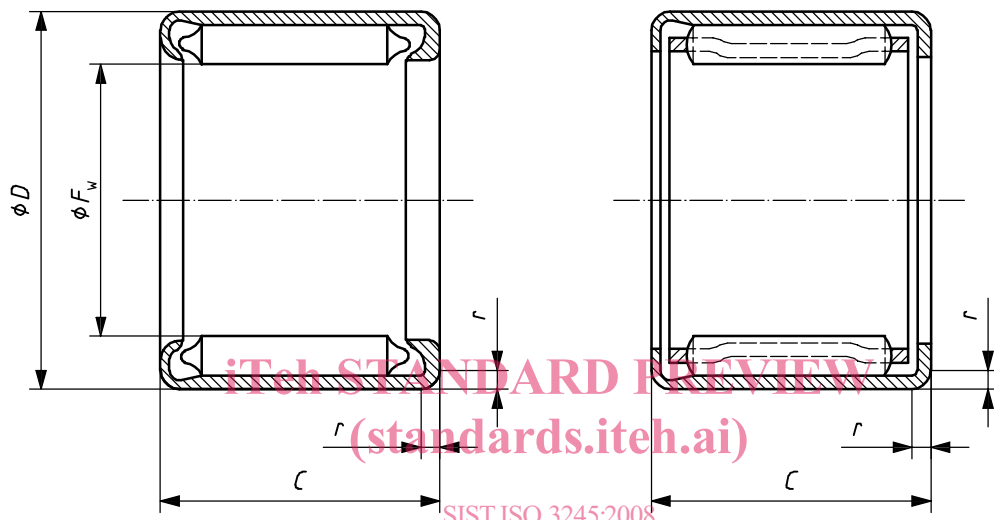

SIST ISO 3245:2008  
<https://standards.iteh.ai/catalog/standards/sist/d791dfd6-a2ec-4129-9df5-c5de719054/sist-iso-3245-2008>

a) With open ends

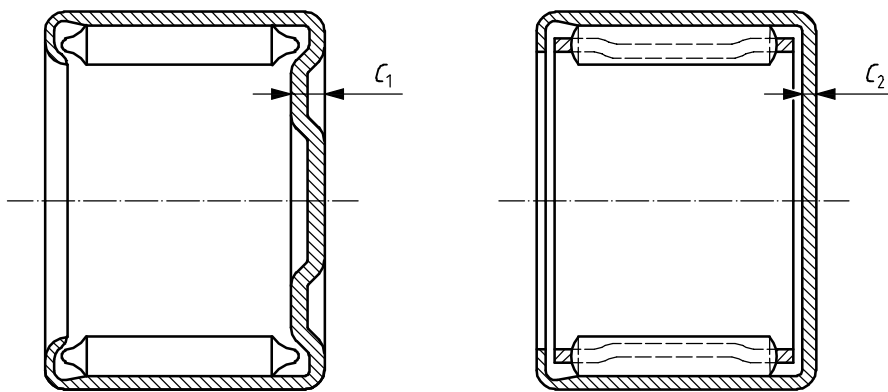

b) With closed end

Figure 1 — Needle roller bearings, drawn cup without inner ring

1) The smallest single bore diameter of the needle roller complement is the diameter of the cylinder which, when placed in the needle roller complement bore, results in zero radial clearance in at least one radial direction.



## 5 Boundary dimensions

The boundary dimensions of drawn cup needle roller bearings, without inner ring, closed end and open ends, of diameter series 1D are given in Table 1, those of diameter series 2D are given in Table 2.

The maximum limits of  $C_1$  and  $C_2$  are given to enable the user to avoid contact between the end face of the shaft and the internal end face of the drawn cup. If contact between these faces is required, the user should consult the bearing manufacturer.

**Table 1 — Boundary dimensions of needle roller bearings without inner ring, with open ends or closed end — Diameter series 1D**

Dimensions in millimetres

$F_w$	$D$	C								$C_1^a$ max.	$C_2^a$ max.	$r_{s\ min}^b$
		Dimension series										
		21D	31D	41D	51D	61D	71D	81D	91D			
4	8	7	<u>8</u>	9	—	—	—	—	—	1,9	1	0,3
5	9	7	8	<u>9</u>	—	—	—	—	—	1,9	1	0,4
6	10	7	8	<u>9</u>	10	—	—	—	—	1,9	1	0,4
7	11	7	8	<u>9</u>	10	12	—	—	—	1,9	1	0,4
8	12	7	8	9	10	12	—	—	—	1,9	1	0,4
9	13	7	<u>8</u>	9	<u>10</u>	12	14	—	—	1,9	1	0,4
10	14	7	8	9	<u>10</u>	12	14	—	—	1,9	1	0,4
12	16	7	8	<u>9</u>	<u>10</u>	12	14	—	—	1,9	1	0,4
14	20	10	<u>12</u>	14	<u>16</u>	18	20	—	—	2,8	1,3	0,4
15	21	10	12	14	<u>16</u>	18	20	—	—	2,8	1,3	0,4
16	22	10	<u>12</u>	14	<u>16</u>	18	20	—	—	2,8	1,3	0,4
17	23	10	12	14	<u>16</u>	18	20	—	—	2,8	1,3	0,4
18	24	10	<u>12</u>	14	<u>16</u>	18	20	—	—	2,8	1,3	0,4
20	26	10	<u>12</u>	14	<u>16</u>	18	20	—	—	2,8	1,3	0,4
22	28	10	<u>12</u>	14	<u>16</u>	18	20	—	—	2,8	1,3	0,4
25	32	12	14	<u>16</u>	18	<u>20</u>	24	28	32	2,8	1,3	0,8
28	35	12	14	<u>16</u>	18	<u>20</u>	24	28	32	2,8	1,3	0,8
30	37	12	14	<u>16</u>	18	<u>20</u>	24	28	32	2,8	1,3	0,8
32	39	12	14	16	18	20	24	28	32	2,8	1,3	0,8
35	42	12	14	<u>16</u>	18	20	24	28	32	2,8	1,3	0,8
38	45	12	14	16	18	20	24	28	32	2,8	1,3	0,8
40	47	12	14	<u>16</u>	18	20	24	28	32	2,8	1,3	0,8
42	49	12	14	16	18	20	24	28	32	2,8	1,3	0,8
45	52	12	14	<u>16</u>	18	20	24	28	32	2,8	1,3	0,8
50	58	14	16	18	<u>20</u>	<u>24</u>	28	32	36	2,8	1,6	0,8
55	63	14	16	18	<u>20</u>	<u>24</u>	28	32	36	2,8	1,6	0,8
60	68	14	16	18	20	24	28	32	36	2,8	1,6	0,8
65	73	14	16	18	20	24	28	32	36	2,8	1,6	0,8
70	78	14	16	18	20	24	28	32	36	2,8	1,6	0,8

NOTE Underlined values are the preferred dimensions.

<sup>a</sup> No minimum limit is specified for thickness of the closed end.

<sup>b</sup> No maximum limit is specified for chamfer dimensions.