



SLOVENSKI STANDARD SIST EN 16475-7:2016

01-marec-2016

Dimovodne naprave - Oprema - 7. del: Dežne kape - Zahteve in preskusne metode

Chimneys - Accessories - Part 7: Rain caps - Requirements and test methods

Abgasanlagen - Zubehörteile - Teil 7: Regenhauben - Anforderungen und Prüfverfahren

Conduits de cheminée - Accessoires - Partie 7: Chapeaux pare-pluie - Exigences et méthodes d'essai

(standards.iteh.ai)

Ta slovenski standard je istoveten z: EN 16475-7:2016

<https://standards.iteh.ai/catalog/standards/sist/29e33a8b-b0b8-492e-bb17-50398caa4a8e/sist-en-16475-7-2016>

ICS:

91.060.40 Dimniki, jaški, kanali Chimneys, shafts, ducts

SIST EN 16475-7:2016

en,fr,de

iTeh STANDARD PREVIEW
(standards.iteh.ai)

SIST EN 16475-7:2016

<https://standards.iteh.ai/catalog/standards/sist/29e33a8b-b0b8-492e-bb17-50398caa4a8e/sist-en-16475-7-2016>

EUROPEAN STANDARD

EN 16475-7

NORME EUROPÉENNE

EUROPÄISCHE NORM

January 2016

ICS 91.060.40

English Version

Chimneys - Accessories - Part 7: Rain caps - Requirements and test methods

Conduits de cheminée - Accessoires - Partie 7:
Chapeaux pare-pluie - Exigences et méthodes d'essai

Abgasanlagen - Zubehörteile - Teil 7: Regenhauben -
Anforderungen und Prüfmethoden

This European Standard was approved by CEN on 27 November 2015.

CEN members are bound to comply with the CEN/CENELEC Internal Regulations which stipulate the conditions for giving this European Standard the status of a national standard without any alteration. Up-to-date lists and bibliographical references concerning such national standards may be obtained on application to the CEN-CENELEC Management Centre or to any CEN member.

This European Standard exists in three official versions (English, French, German). A version in any other language made by translation under the responsibility of a CEN member into its own language and notified to the CEN-CENELEC Management Centre has the same status as the official versions.

CEN members are the national standards bodies of Austria, Belgium, Bulgaria, Croatia, Cyprus, Czech Republic, Denmark, Estonia, Finland, Former Yugoslav Republic of Macedonia, France, Germany, Greece, Hungary, Iceland, Ireland, Italy, Latvia, Lithuania, Luxembourg, Malta, Netherlands, Norway, Poland, Portugal, Romania, Slovakia, Slovenia, Spain, Sweden, Switzerland, Turkey and United Kingdom.

<https://standards.iteh.ai/catalog/standards/sist/29e33a8b-b0b8-492e-bb17-50398caa4a8e/sist-en-16475-7-2016>



EUROPEAN COMMITTEE FOR STANDARDIZATION
COMITÉ EUROPÉEN DE NORMALISATION
EUROPÄISCHES KOMITEE FÜR NORMUNG

CEN-CENELEC Management Centre: Avenue Marnix 17, B-1000 Brussels

Contents

Page

European foreword.....	5
Introduction	6
1 Scope	7
2 Normative references	7
3 Terms and definitions	7
4 Product characteristics	8
4.1 General.....	8
4.2 Dimensions and tolerances	8
4.3 Mechanical resistance and stability	9
4.3.1 Compressive strength.....	9
4.3.2 Wind load	9
4.3.3 Resistance to freeze-thaw	9
4.4 Thermal performance	9
4.4.1 Reaction to fire.....	9
4.4.2 Fire resistance	9
4.5 Hygiene, health and environment.....	10
4.5.1 Corrosion resistance	10
4.5.2 Dangerous substances.....	10
4.6 Additional criteria for chimney operation.....	10
4.6.1 Cleaning of the chimney.....	10
4.6.2 Rainwater ingress	10
4.6.3 Flow resistance of the rain cap.....	11
4.6.4 Ice formation.....	11
5 Testing, assessment and sampling methods	11
5.1 Mechanical resistance and stability	11
5.1.1 General.....	11
5.1.2 Compressive strength.....	11
5.1.3 Wind load	12
5.2 Thermal performance	13
5.2.1 Test assembly	13
5.2.2 Test Procedure	14
5.3 Additional criteria for chimney operation.....	15
5.3.1 Rainwater ingress	15
5.3.2 Flow resistance of the rain cap.....	17
6 Assessment and Verification of the Constancy of Performance (AVCP).....	19
6.1 General.....	19
6.2 Type testing.....	19
6.2.1 General.....	19
6.2.2 Manufacturer's declaration for type test.....	20
6.2.3 Test samples, testing and compliance criteria	20
6.2.4 Sampling for type testing	20
6.2.5 Further type testing.....	20
6.2.6 Test reports.....	21

6.2.7	Shared other party results	21
6.2.8	Cascading determination of the product type results	21
6.3	Factory production control (FPC)	23
6.3.1	General	23
6.3.2	Sampling	23
6.4	Requirements.....	23
6.4.1	General	23
6.4.2	Equipment.....	24
6.4.3	Raw materials and components	24
6.4.4	Product specific requirements	26
6.4.5	Procedure for modifications.....	27
7	Product information.....	27
7.1	Manufacturer's instructions	27
7.2	Minimum information to be included in the manufacturer's instructions	27
8	Classification and designation	28
8.1	General	28
8.2	Temperature classes and test temperature.....	28
8.3	Corrosion resistance.....	29
8.4	Soot fire resistance.....	29
9	Marking, labelling and packaging.....	30
9.1	Rain cap.....	30
9.2	Packaging.....	30
iTeh STANDARD PREVIEW (standards.iteh.ai)		
Annex A (informative)	Deemed to satisfy information.....	31
Annex B (informative)	Coefficients of flow resistance	33
Annex C (normative)	Choice of size for type test and sampling.....	34
C.1	General	34
C.2	Fire resistance	34
C.3	Mechanical resistance and stability.....	34
C.4	Rainwater ingress.....	34
C.5	Flow resistance.....	34
C.6	Resistance to freeze-thaw	34
Annex D (informative)	Example of sampling for factory production control.....	35
D.1	Sampling plans.....	35
D.1.1	General	35
D.1.2	Acceptable quality level (AQL).....	35
D.1.3	The inspection level.....	35
D.1.4	Normal, tightened or reduce inspection	35
D.1.5	Single, double, multiple or sequential sampling.....	35
D.1.6	Batch quantity.....	35
D.2	Inspection levels and procedures.....	36
D.2.1	Incoming material	36
D.2.2	In-process inspection	36

EN 16475-7:2016 (E)

D.2.3	Volume and density checks	36
D.2.4	Finished goods checks	36
Annex E (normative) Method of measuring the hot gas temperature		37
Annex ZA (informative) Relationship of this European Standard with Regulation (EU) No.305/2011		38
ZA.1	Scope and relevant characteristics	38
ZA.2	System of Assessment and Verification of Constancy of Performance (AVCP)	38
ZA.3	Assignment of AVCP tasks	38
Bibliography		40

iTeh STANDARD PREVIEW (standards.iteh.ai)

SIST EN 16475-7:2016

<https://standards.iteh.ai/catalog/standards/sist/29e33a8b-b0b8-492e-bb17-50398caa4a8e/sist-en-16475-7-2016>

European foreword

This document (EN 16475-7:2016) has been prepared by Technical Committee CEN/TC 166 “Chimneys”, the secretariat of which is held by ASI.

This European Standard shall be given the status of a national standard, either by publication of an identical text or by endorsement, at the latest by July 2016, and conflicting national standards shall be withdrawn at the latest by October 2017.

Attention is drawn to the possibility that some of the elements of this document may be the subject of patent rights. CEN [and/or CENELEC] shall not be held responsible for identifying any or all such patent rights.

This document has been prepared under a mandate given to CEN by the European Commission and the European Free Trade Association, and supports essential requirements of EU Directive(s).

For relationship with EU Directive(s), see informative Annex ZA, which is an integral part of this document.

According to the CEN/CENELEC Internal Regulations, the national standards organizations of the following countries are bound to implement this European Standard: Austria, Belgium, Bulgaria, Croatia, Cyprus, Czech Republic, Denmark, Estonia, Finland, Former Yugoslav Republic of Macedonia, France, Germany, Greece, Hungary, Iceland, Ireland, Italy, Latvia, Lithuania, Luxembourg, Malta, Netherlands, Norway, Poland, Portugal, Romania, Slovakia, Slovenia, Spain, Sweden, Switzerland, Turkey and the United Kingdom.

[SIST EN 16475-7:2016](https://standards.iteh.ai/catalog/standards/sist/29e33a8b-b0b8-492e-bb17-50398caa4a8e/sist-en-16475-7-2016)

<https://standards.iteh.ai/catalog/standards/sist/29e33a8b-b0b8-492e-bb17-50398caa4a8e/sist-en-16475-7-2016>

EN 16475-7:2016 (E)**Introduction**

EN 16475-7 is a part of the series of standards for “Chimneys — Accessories” and consists of:

- *Part 1: Silencers*
- *Part 2: Chimney fans*
- *Part 3: Draught regulators, standstill opening devices and combined secondary air devices*
- *Part 4: Flue dampers*
- *Part 5: Explosion/implosion relief devices*
- *Part 6: Access components*
- *Part 7: Rain caps (this part)*

iTeh STANDARD PREVIEW
(standards.iteh.ai)

SIST EN 16475-7:2016

<https://standards.iteh.ai/catalog/standards/sist/29e33a8b-b0b8-492e-bb17-50398caa4a8e/sist-en-16475-7-2016>

1 Scope

This European Standard specifies requirements and test methods for rain caps that are used as components, subject to flue gas, in order to protect against rain entry into the chimney flues.

Rain caps which are part of components of a system chimney or other components of a chimney such as terminals, are not covered by this European Standard.

It also specifies the requirements for marking, manufacturers' instruction, product information and attestation and verification of constancy of performance (AVCP).

NOTE Rain caps according to this standard are suitable for both dry and wet chimney applications.

2 Normative references

The following documents, in whole or in part, are normatively referenced in this document and are indispensable for its application. For dated references, only the edition cited applies. For undated references, the latest edition of the referenced document (including any amendments) applies.

EN 206, *Concrete — Specification, performance, production and conformity*

EN 1443, *Chimneys — General requirements*

EN 1856-2:2009, *Chimneys — Requirements for metal chimneys — Part 2: Metal flue liners and connecting flue pipes*

EN 1857, *Chimneys — Components — Concrete flue liners*

EN 1858, *Chimneys — Components — Concrete flue blocks*

EN 14297, *Chimneys — Freeze-thaw resistance test method for chimney products*

EN 14471:2013+A1:2015, *Chimneys — System chimneys with plastic flue liners — Requirements and test methods*

3 Terms and definitions

For the purposes of this document, the terms and definitions given in EN 1443 and the following apply.

3.1

rain cap

product to protect against rain entry into the chimney flue

3.2

flow resistance of the rain cap

additional pressure loss due to the flow of the flue gas passing the rain cap

3.3

nominal flue size

numerical designation of flue size which the rain cap is protecting against rain ingress, which is a convenient round number equal to or approximately equal to either the internal diameter in millimetres of circular flue liners, the internal width in millimetres of square flue liners or the internal width and breadth in millimetres of the cross section of rectangular flue liners

EN 16475-7:2016 (E)**3.4****rain cap size**

outer dimension or dimensions of the projected horizontal surface of the rain cap, expressed in millimetres

3.5**free area**

vertical dimension from the top of the flue outlet to the underside of the rain cap edge multiplied by the perimeter of the flue which the rain cap protects, reduced by the area of e.g. any support legs, bands, bird or spark guard mesh, expressed in square millimetres

4 Product characteristics**4.1 General**

Recommended minimum material specifications for rain caps are the following (see Annex A):

- a) Metal rain caps made of material quality 1.4401 with a wall thickness of the cap of at least 0,6 mm, at least three supports with a wall thickness of each at least 1,0 mm, method of fixings ww, wr, rr, b or st and a relation between dome/pyramid and height/size of at least 10 %.
- b) Metal rain caps made of material quality 1.4301 with a wall thickness of the cap of at least 0,6 mm, at least three supports with a wall thickness of each at least 1,0 mm, method of fixings ww, wr, rr, b or st and a relation between dome/pyramid and height/size of at least 10 %.
- c) Metal rain caps made of material quality EN AW – 4047A with a wall thickness of the cap of at least 1,5 mm, at least three supports with a wall thickness of each at least 1,5 mm, method of fixings rr, b or st and a relation between dome/pyramid and height/size of at least 10 %.
- d) Concrete rain caps with a compressive strength of the concrete of at least C25/30 according to EN 206 (characteristic value ≥ 25 MPa on 150×300 cylinder), a relation between thickness and length of longest side of at least 20 % and fixings with tenon and mortise or similar assembly shape + mortar or jointing material.

NOTE Method of fixing ww = double weld, wr = weld and rivet, rr = double rivet, b = bolt and washer, st = single self-tapping screw.

Metal:

The material of a metal rain cap shall be in accordance with EN 1856-2.

Concrete:

The material of a concrete rain cap shall be in accordance with EN 1857 or EN 1858.

Plastic:

The material of a plastic rain cap in contact with combustion products shall be in accordance with the chimney requirements of EN 14471 with the durability against UV (location class) LE.

4.2 Dimensions and tolerances

The thickness of material of the individual components of the rain cap shall be not less than that declared by the manufacturer.

4.3 Mechanical resistance and stability

4.3.1 Compressive strength

When tested in accordance with the test method described in 5.1.2, the rain cap shall withstand a load of $2,9 \text{ kN/m}^2 \pm 5 \%$ of the outer dimension of the horizontal surface of the rain cap without reducing the original free area of the rain cap by more than 10 % after the test.

NOTE 1 The value corresponds to the maximum snow load zone in accordance with EN 1991-1-3.

Metal and concrete rain caps as described in 4.1 a) to d) are considered to meet the requirement.

NOTE 2 Method of fixing ww = double weld, wr = weld and rivet, rr = double rivet, b = bolt and washer, st = single self-tapping screw.

4.3.2 Wind load

When the rain cap is tested according to the test method described in 5.1.3, the rain cap shall not show a reduction of the original free area of the rain cap by more than 10 % after the test when a minimum horizontal traction load of $1,5 \text{ kN/m}^2$ of the laterally projected surface area is applied (see Figure 2 a)), and when a vertical traction load of $0,75 \text{ kN/m}^2$ of the upward projected surface area is applied (see Figure 2 b)).

Metal and concrete rain caps as described in 4.1 a) to d) are considered to meet the requirement.

4.3.3 Resistance to freeze-thaw

Rain caps shall be tested for their freeze-thaw resistance in accordance with EN 14297.

Metal and plastic products are considered deemed to satisfy freeze-thaw resistance.

4.4 Thermal performance

4.4.1 Reaction to fire

For plastic materials the manufacturer shall declare the class of reaction to fire as defined in EN 14471:2013+A1:2015, 4.10, and test it in accordance with EN 14471:2013+A1:2015, 7.7.8.

4.4.2 Fire resistance

4.4.2.1 Heat stress

When the rain cap is tested in accordance with 5.2.2.1, the rain cap shall not show a reduction of the original free area of the rain cap by more than 10 % after the test.

Metal rain caps as described in 4.1 a) are deemed to satisfy the requirements of T600 and shall be designated as T600.

Metal rain caps as described in 4.1 b) are deemed to satisfy the requirements of T300 and shall be designated as T300.

Metal rain caps as described in 4.1 c) are deemed to satisfy the requirements of T200 and shall be designated as T200.

Concrete rain caps as described in 4.1 d) are deemed to satisfy the requirements of T450 and shall be designated as T450.

EN 16475-7:2016 (E)**4.4.2.2 Resistance to sootfire**

When the rain cap is tested in accordance with 5.2.2.2, the rain cap shall not show a reduction of the original free area of the rain cap by more than 10 % after the test.

Metal rain caps as described in 4.1 a) are considered to meet the requirement.

Concrete rain caps as described in 4.1 d) are considered to meet the requirement.

4.5 Hygiene, health and environment**4.5.1 Corrosion resistance**

The corrosion resistance of the material of the rain cap shall be in accordance with the material quality of the equivalent flue liner material for that chimney designation as given in EN 1857, EN 1856-2 or EN 14471.

Metal rain caps as described in 4.1 a) are considered to be designated 3.

Metal rain caps as described in 4.1 b) are considered to be designated 2.

Metal rain caps made of material quality EN AW – 4047A and constructed as described in 4.1 are considered to be designated 1.

Concrete rain caps made of material according to EN 1857 (or EN 1858) are considered to be designated 3.

4.5.2 Dangerous substances

National regulations on dangerous substances may require verification and declaration on release, and sometimes content, when construction products covered by this standard are placed on those markets.

In the absence of European harmonized test methods, verification and declaration on release/content should be done taking into account national provisions in the place of use.

NOTE An informative database covering European and national provisions on dangerous substances is available at the Construction website on EUROPA accessed through:
<http://ec.europa.eu/enterprise/construction/cpd-ds/>

4.6 Additional criteria for chimney operation**4.6.1 Cleaning of the chimney**

If the cleaning of the chimney is intended to be made with the rain cap in position and the rain cap cannot be removed easily, the distance shall be sufficient to allow a cleaning brush of the size appropriate to the flue to be cleaned to exit the flue. A distance of at least 100 mm is recommended.

If the rain cap is removable for cleaning purposes, it shall be secured appropriately against falling.

4.6.2 Rainwater ingress

When the rain cap is tested according to the test method described in 5.3.1, the mass of the water collected in the flue shall not exceed $0,05 \text{ mm}^3/\text{s}$ per millimetre of flue diameter.

Rain caps with the overall dimension providing an angle of at least 27° from the vertical of a line from the edge of the rain cap to the edge of flue are considered to meet the requirement under no wind conditions.

It is recommended that the size of the rain cap is at least of the same size as the exterior dimension of the top of the chimney in order to protect the top of the chimney from rain where it is otherwise not protected.

4.6.3 Flow resistance of the rain cap

The manufacturer shall declare the coefficient of flow resistance of the rain cap.

The declared value shall be determined according to the test method described in 5.3.2 or obtained from data given in Table B.1.

A zeta value of maximum 1.5 is recommended. A free area of at least 2 times the flue area satisfies this recommendation, without testing.

4.6.4 Ice formation

A rain cap subject to ice formation shall have an overlap of at least 50 mm greater than the chimney outer dimension in all directions.

5 Testing, assessment and sampling methods

5.1 Mechanical resistance and stability

5.1.1 General

The rain cap shall be mounted according to the manufacturer's instructions on the top of a test assembly supported. **iTeh STANDARD PREVIEW**

5.1.2 Compressive strength (standards.iteh.ai)

5.1.2.1 Test assembly

SIST EN 16475-7:2016

<https://standards.iteh.ai/catalog/standards/sist/29e33a8b-b0b8-492e-bb17-505900140050/sist-en-16475-7-2016>

The rain cap shall be mounted according to the manufacturer's instructions on a simulated chimney top supported (see Figure 1).

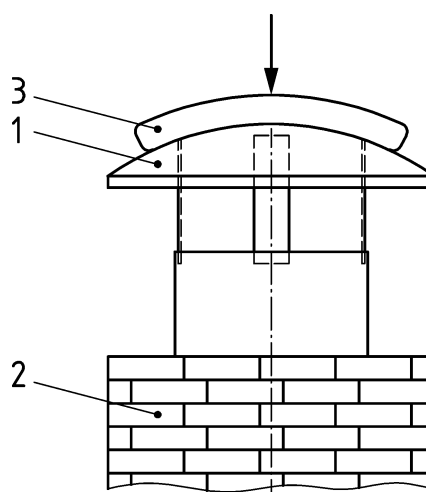

Key

- 1 rain cap
- 2 chimney
- 3 sand bag

Figure 1 — Example of a test assembly for compressive strength