

---

---

**Snowboards — Binding mounting area —  
Part 2:  
Requirements and test methods for  
snowboards with inserts**

*Surfs des neiges — Zone de montage de la fixation —  
Partie 2: Exigences et méthodes d'essai relatives aux surfs des neiges  
munis d'inserts*

iTeh STANDARD PREVIEW  
(standards.iteh.ai)

ISO 10958-2:2004

<https://standards.iteh.ai/catalog/standards/sist/e2a61662-18a6-4594-9520-0d65a54ae152/iso-10958-2-2004>



**PDF disclaimer**

This PDF file may contain embedded typefaces. In accordance with Adobe's licensing policy, this file may be printed or viewed but shall not be edited unless the typefaces which are embedded are licensed to and installed on the computer performing the editing. In downloading this file, parties accept therein the responsibility of not infringing Adobe's licensing policy. The ISO Central Secretariat accepts no liability in this area.

Adobe is a trademark of Adobe Systems Incorporated.

Details of the software products used to create this PDF file can be found in the General Info relative to the file; the PDF-creation parameters were optimized for printing. Every care has been taken to ensure that the file is suitable for use by ISO member bodies. In the unlikely event that a problem relating to it is found, please inform the Central Secretariat at the address given below.

**iTeh STANDARD PREVIEW**  
**(standards.iteh.ai)**

[ISO 10958-2:2004](https://standards.iteh.ai/catalog/standards/sist/e2a61662-18a6-4594-9520-0d65a54ae152/iso-10958-2-2004)

<https://standards.iteh.ai/catalog/standards/sist/e2a61662-18a6-4594-9520-0d65a54ae152/iso-10958-2-2004>

© ISO 2004

All rights reserved. Unless otherwise specified, no part of this publication may be reproduced or utilized in any form or by any means, electronic or mechanical, including photocopying and microfilm, without permission in writing from either ISO at the address below or ISO's member body in the country of the requester.

ISO copyright office  
Case postale 56 • CH-1211 Geneva 20  
Tel. + 41 22 749 01 11  
Fax + 41 22 749 09 47  
E-mail [copyright@iso.org](mailto:copyright@iso.org)  
Web [www.iso.org](http://www.iso.org)

Published in Switzerland

## Foreword

ISO (the International Organization for Standardization) is a worldwide federation of national standards bodies (ISO member bodies). The work of preparing International Standards is normally carried out through ISO technical committees. Each member body interested in a subject for which a technical committee has been established has the right to be represented on that committee. International organizations, governmental and non-governmental, in liaison with ISO, also take part in the work. ISO collaborates closely with the International Electrotechnical Commission (IEC) on all matters of electrotechnical standardization.

International Standards are drafted in accordance with the rules given in the ISO/IEC Directives, Part 2.

The main task of technical committees is to prepare International Standards. Draft International Standards adopted by the technical committees are circulated to the member bodies for voting. Publication as an International Standard requires approval by at least 75 % of the member bodies casting a vote.

Attention is drawn to the possibility that some of the elements of this document may be the subject of patent rights. ISO shall not be held responsible for identifying any or all such patent rights.

ISO 10958-2 was prepared by Technical Committee ISO/TC 83, *Sports and recreational equipment*, Subcommittee SC 4, *Skis and snowboards*.

This second edition cancels and replaces the first edition (ISO 10958-2:1999), which has been technically revised.

ISO 10958 consists of the following parts, under the general title *Snowboards — Binding mounting area*:

- *Part 1: Requirements and test methods for snowboards without inserts*
- *Part 2: Requirements and test methods for snowboards with inserts*

**iTeh STANDARD PREVIEW**  
**(standards.iteh.ai)**

ISO 10958-2:2004

<https://standards.iteh.ai/catalog/standards/sist/e2a61662-18a6-4594-9520-0d65a54ae152/iso-10958-2-2004>

# Snowboards — Binding mounting area —

## Part 2: Requirements and test methods for snowboards with inserts

### 1 Scope

This part of ISO 10958 specifies requirements and test methods for snowboards on which bindings are attached by means of inserts that are not removable and screws.

This part of ISO 10958 does not apply to snowboards for children with a mass less than 25 kg.

It contains data for the manufacturer of snowboards, bindings and retention devices concerning dimensions, tests and other specifications for the binding mounting area.

For dimensions with no tolerance indicated, a tolerance of  $\pm 1$  mm is valid.

### 2 Normative references

The following referenced documents are indispensable for the application of this document. For dated references, only the edition cited applies. For undated references, the latest edition of the referenced document (including any amendments) applies.

ISO 68-1:1998, *ISO general purpose screw threads — Basic profile — Part 1: Metric screw threads*

### 3 Terms and definitions

For the purposes of this document, the terms and definitions given in ISO 68-1 and the following apply.

#### 3.1

##### **insert**

reusable commonly threaded attachment point permanently fixed in the snowboard at the time of manufacture, used to mount the bindings to the snowboard and typically arranged in a pattern corresponding to a particular binding manufacturer's pattern

#### 3.2

##### **retention strength**

axial pull-out force of an insert in a snowboard tested in accordance with 6.1 and 7.1

#### 3.3

##### **spin resistance**

moment required to rotate an insert tested in accordance with 6.2 and 7.2

**3.4**  
**screw thread engagement**

*E*  
number of threads engaged by a standard screw in an insert

See Figure 1.

**3.5**  
**insert well depth**

*i*  
distance within the insert well from the snowboard top surface to the unobstructed bottom clearance of the binding-insert

See Figure 1.

**3.6**  
**countersink depth**

*c*  
distance from the snowboard top surface to the first thread of the insert

See Figure 1.

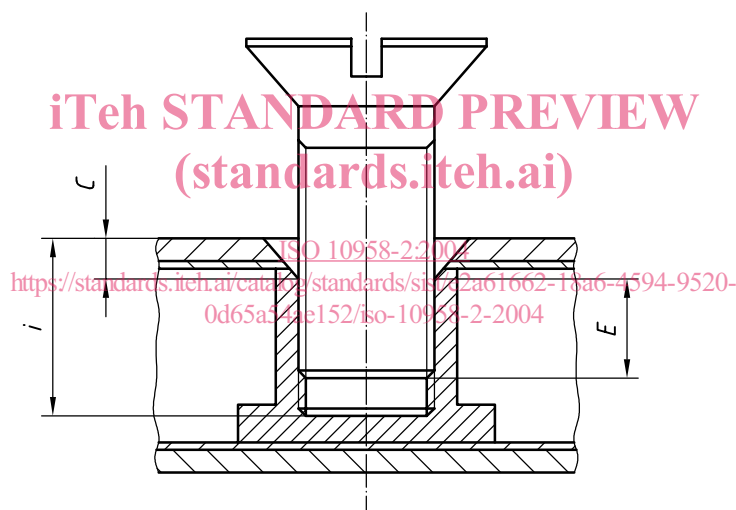

**Figure 1 — Illustration of screw thread engagement, insert well depth and countersink depth**

**4 Specifications for design of snowboard insert**

**4.1** Inserts shall have an M6x1, 6H class internal thread with standard tolerances in accordance with ISO 68-1.

**4.2** Insert screws shall have an M6x1, 6g class external thread with standard tolerances in accordance with ISO 68-1.

**4.3** The snowboard design shall provide, for a minimum insert well depth *i* of 5,5 mm, a minimum screw engagement *E* of 2,0 threads. The length of the screw shall allow a gap between the end of the screw and the bottom of the insert. The effective threaded depth of the insert shall be at least 5,5 mm.

The value of 2 threads has been verified by extensive tests carried out by snowboard manufacturers. It is recommended that self-locking screws are used.

**4.4** The maximum countersink depth *c* shall be 2,5 mm.

## 5 Strength requirements

### 5.1 Retention strength

When tested in accordance with 7.1, inserts in a snowboard shall have a minimum retention strength of 4 500 N for those snowboards with a suggested rider mass of 45 kg or more; and a minimum retention strength of 3 500 N for those snowboards with a suggested rider mass between 25 kg and 45 kg.

### 5.2 Spin resistance

When tested in accordance with 7.2, inserts in a snowboard shall have a minimum spin resistance of 20 N·m.

## 6 Test apparatus

### 6.1 Retention-strength test apparatus

Universal test machine (UTM), with a pull-out device according to Figure 2, having a minimum load range of 10 000 N.

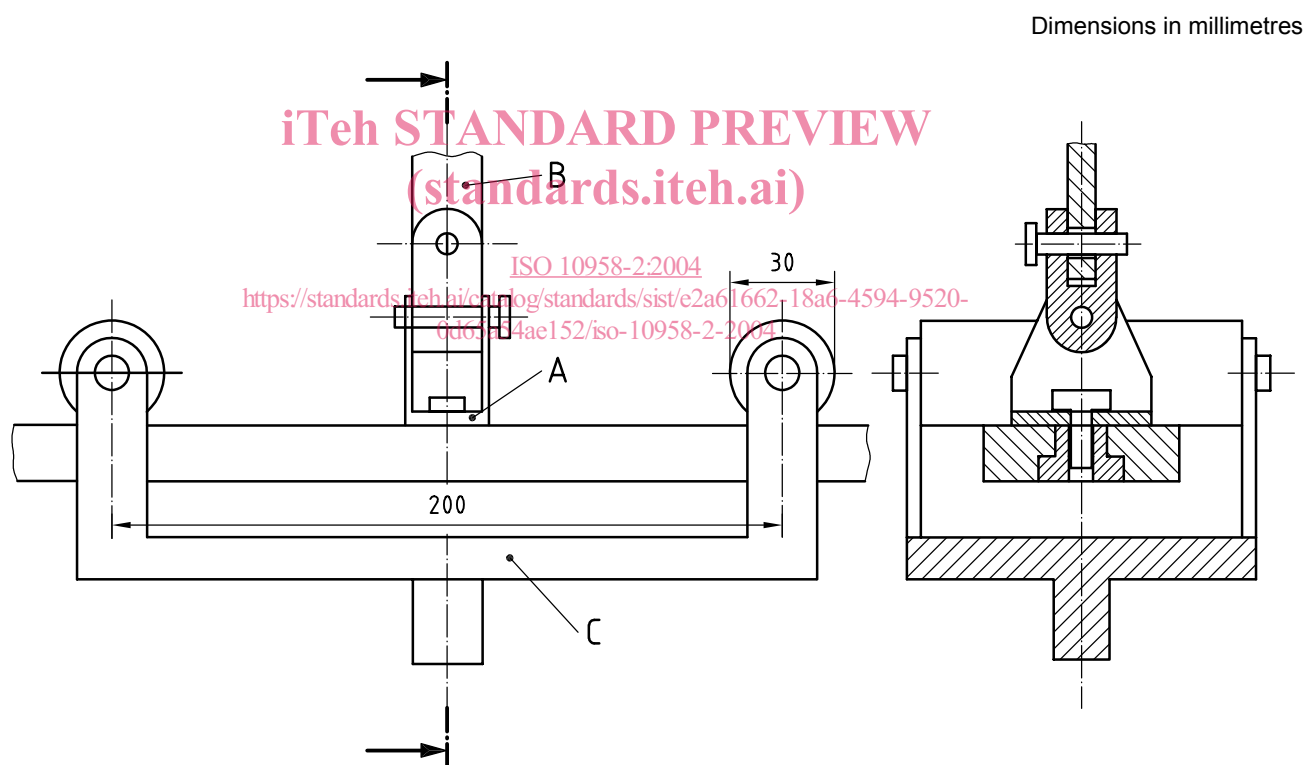

Figure 2 — Universal test machine with pull-out device

The pull-out device (see Figure 2) shall consist of

- a rigid steel attachment plate (A) with one hole of diameter 6,5 mm,
- a universal joint (B) which is connected to the attachment plate and to the clamping device of the test machine, and
- a snowboard support (C) with two support rollers with a distance of 200 mm between them.

## 6.2 Spin resistance test apparatus

6.2.1 **Device**, capable of applying a torque directly to the insert (e.g. long screw with counter-nut).

6.2.2 **Handheld torque gauge**, able to read to  $\pm 2,5$  N·m.

6.2.3 **C-Clamps**, able to hold the snowboard stationary on a flat surface.

## 7 Test procedures

### 7.1 Retention-strength test procedure

7.1.1 Test the snowboards at room temperature,  $(23 \pm 5)$  °C.

7.1.2 Cycle the UTM at a crosshead rate of 20 mm/min  $\pm 20$  %.

7.1.3 Stop the test at a load of 4 500 N, respectively 3 500 N as appropriate.

### 7.2 Spin-resistance test procedure

7.2.1 Test the inserts at room temperature,  $(23 \pm 5)$  °C.

7.2.2 Clamp the snowboard to a flat surface.

7.2.3 Insert the test screw into the insert, engaging to the full depth of the insert.

7.2.4 Torque the insert up to the required torque of 20 N·m.

<https://standards.iteh.ai/catalog/standards/sist/e2a61662-18a6-4594-9520-0d65a54ae152/iso-10958-2-2004>

## 8 Marking

Snowboards with a suggested rider mass between 25 kg and 45 kg shall be marked with a clearly visible, permanent sign of minimum size 10 mm, placed outside the binding mounting area. The sign shall be as follows:



**25 kg - 45 kg**



## 9 Test report

The test report shall include the following information:

- a) a reference to this part of ISO 10958;
- b) snowboard/binding insert manufacturer, model/style and length;
- c) snowboard serial number;
- d) compliance with the requirements according to Clause 5;
- e) any deviations from this part of ISO 10958;
- f) date of tests.

**iTeh STANDARD PREVIEW**  
**(standards.iteh.ai)**

[ISO 10958-2:2004](https://standards.iteh.ai/catalog/standards/sist/e2a61662-18a6-4594-9520-0d65a54ae152/iso-10958-2-2004)

<https://standards.iteh.ai/catalog/standards/sist/e2a61662-18a6-4594-9520-0d65a54ae152/iso-10958-2-2004>