



Designation: D4320 – 04

# Standard Practice for Laboratory Preparation of Chemically Grouted Soil Specimens for Obtaining Design Strength Parameters<sup>1</sup>

This standard is issued under the fixed designation D4320; the number immediately following the designation indicates the year of original adoption or, in the case of revision, the year of last revision. A number in parentheses indicates the year of last reapproval. A superscript epsilon ( $\epsilon$ ) indicates an editorial change since the last revision or reapproval.

## 1. Scope\*

1.1 This practice covers the laboratory preparation of chemically grouted soil specimens for use in laboratory tests to determine design strength parameters.

NOTE 1—This practice may not be applicable to grout mixtures with gel times shorter than the time required to saturate the specimen with grout.

1.2 The specimens are intended for both strength and modulus determination in unconfined and confined compression testing.

NOTE 2—Preparation methods for specimens to be used for other purposes are described in Test Methods D4219 and D5202.

1.3 This practice requires the injection of grout into soil specimens already fabricated to a desired density.

1.4 All observed and calculated values shall conform to the guidelines for significant digits and rounding established in Practice D6026.

1.4.1 The method used to specify how data are collected, calculated, or recorded in this standard is not directly related to the accuracy to which the data can be applied in design or other uses, or both. How one applies the results obtained using this standard is beyond its scope.

1.5 The values stated in inch-pound units are to be regarded as standard, except as noted below. The values given in parentheses are mathematical conversions to SI units, which are provided for information only and are not considered standard.

1.6 *This standard does not purport to address all of the safety concerns, if any, associated with its use. It is the responsibility of the user of this standard to establish appropriate safety and health practices and determine the applicability of regulatory requirements prior to use.*

1.7 This practice offers a set of instructions for performing one or more specific operations. This document cannot replace education or experience and should be used in conjunction with professional judgment. Not all aspects of this practice may be

applicable in all circumstances. This ASTM standard is not intended to represent or replace the standard of care by which the adequacy of a given professional service must be judged, nor should this document be applied without consideration of a project's many unique aspects. The word "Standard" in the title of this document means only that the document has been approved through the ASTM consensus process.

1.8 The text of this standard references notes and footnotes which provide explanatory material. These notes and footnotes (excluding those in tables and figures) shall not be considered as requirements of the standard.

## 2. Referenced Documents

2.1 *ASTM Standards:*<sup>2</sup>

D653 Terminology Relating to Soil, Rock, and Contained Fluids

D3740 Practice for Minimum Requirements for Agencies Engaged in Testing and/or Inspection of Soil and Rock as Used in Engineering Design and Construction

D4219 Test Method for Unconfined Compressive Strength Index of Chemical-Grouted Soils

D5202 Test Method for Determining Triaxial Compression Creep Strength of Chemical Grouted Soils

D6026 Practice for Using Significant Digits in Geotechnical Data

## 3. Terminology

3.1 *Definitions:*

3.1.1 For definitions of terms in this standard, refer to Terminology D653.

## 4. Significance and Use

4.1 The purpose of this practice is to prepare specimens of chemically grouted soils for testing in unconfined or triaxial compression, when the test data is to be used for design purposes.

NOTE 3—The quality of the result produced by this standard is dependent on the competence of the personnel performing it, and the

<sup>1</sup> This practice is under the jurisdiction of ASTM Committee D18 on Soil and Rock and is the direct responsibility of Subcommittee D18.15 on Stabilization With Admixtures.

Current edition approved Nov. 1, 2004. Published November 2004. Originally approved in 1984. Last previous edition approved in 2002 as D4320 – 02. DOI: 10.1520/D4320-04.

<sup>2</sup> For referenced ASTM standards, visit the ASTM website, [www.astm.org](http://www.astm.org), or contact ASTM Customer Service at [service@astm.org](mailto:service@astm.org). For *Annual Book of ASTM Standards* volume information, refer to the standard's Document Summary page on the ASTM website.

\*A Summary of Changes section appears at the end of this standard.

suitability of the equipment and facilities used. Agencies that meet the criteria of Practice D3740 are generally considered capable of competent and objective testing/sampling/inspection/etc. Users of this standard are cautioned that compliance with Practice D3740 does not in itself assure reliable results. Reliable results depend on many factors; Practice D3740 provides a means of evaluating some of those factors.

5. Apparatus

5.1 *Specimen Molds*—Molds are to be constructed so that they may be longitudinally split to allow the removal of grouted specimens without the use of a jacking force. They may be sized for the preparation of one or multiple specimens (Multiple specimen molds should be externally marked to indicate desired ends of individual specimens, as an aid in preparation). Molds shall produce specimens with a length-to-diameter ratio between two and three, (2.5 is recommended) and shall have a tolerance of ±0.01 in. (0.25 mm) on the internal diameter. Molds will have top and bottom caps designed to prevent leakage of grout during pressure injection.

NOTE 4—Satisfactory molds, similar to Fig. 1, may be made from an acrylic tube which has been split longitudinally into three pieces (Fig. 2), which allows for the mold to be assembled and disassembled using silicon rubber seals and hose clamps. Equally satisfactory molds can be made by splitting tubes longitudinally with one narrow slit (Fig. 3), which is closed by hose clamps around the tubes and will reopen when the clamps are loosened, thus releasing the specimens. Leakage may be prevented by covering the slit from the inside with tape. Satisfactory seals of end caps may be made by threading the tubing and cap or by external tie rods to hold the caps in place (Fig. 4).

5.2 *Grout Injection System*—A system composed of the following components (Fig. 5):

5.2.1 *Mixing Tank*, capable of being pressurized to 30.0 psi (207 kPa) without leaking and able to contain all of the grout

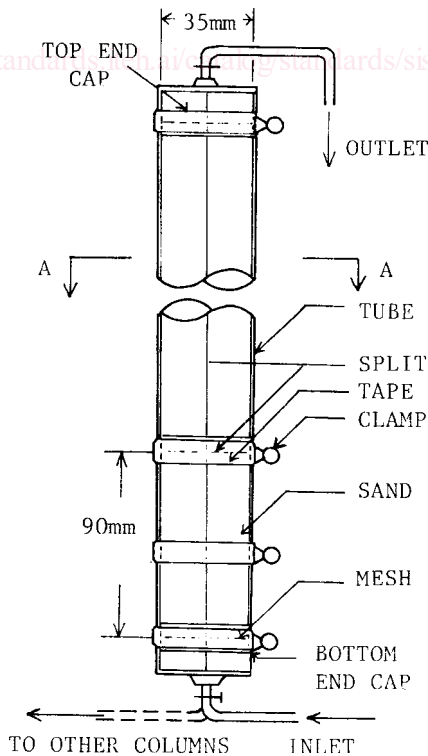
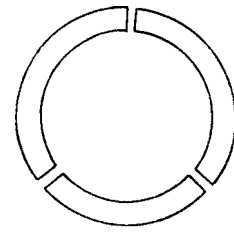
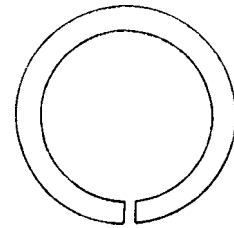

FIG. 1 Specimen Mold



A-A

FIG. 2 Three piece multiple specimen mold



A-A

FIG. 3 Split tube multiple specimen mold

volume to be injected in one grouting operation. The tank will have an internal mixing device (such as a paddle wheel) or be able to accommodate the use of a magnetic stirrer. The tank will be fitted with a regulated air-pressure source and pressure gage.

NOTE 5—Alternatively, proportioning pump sets may be used. Such equipment may be of advantage when the grout gel times are too short for effective use of pressure-tank injection equipment.

5.2.2 *Tubing*, capable of transporting the grout from the mixing tank to the specimen mold or molds to be injected is required. A bleed valve located just before the mold injection inlet allows for air bubbles trapped in the grout lines to be removed before they move into the specimen.

5.3 *Balance*—A balance or scale of 1000-g capacity, sensitive to 0.1 g.

5.4 *Miscellaneous Equipment*—Tools such as: spoons, weighing dishes, etc., for handling and weighing soil and any dry grout components, graduate for measuring water and fluid grout components, tamping rod or vibrating tool or both for compaction of specimens to desired density, nylon screen having openings small enough to retain the soil to be grouted but otherwise as large as possible, and scissors for cutting.

5.5 *Leveling Device*—A leveling plate attached to a rod of sufficient length such that the plate can be oriented perpendicular to the long axis of the mold at any height within the mold, capable of fitting inside the mold with approximately 0.25-in. (6.0-mm) clearance.

5.6 *Moist Room or Cabinet*—A moist room or cabinet capable of maintaining a temperature of 73.4 ± 2.0°F (23.0 ± 1.1°C) and a relative humidity of not less than 96 % for moist curing specimens.

5.7 *Deviations*, from standard curing conditions are to be noted in the report.