**Belt drives — V-belts for the automotive
industry and corresponding pulleys —
Dimensions**

*Transmissions par courroies — Courroies trapézoïdales pour la
construction automobile et poulies correspondantes — Dimensions*

iTeh STANDARD PREVIEW
(standards.iteh.ai)

[ISO 2790:2004](https://standards.iteh.ai/catalog/standards/sist/fe382a5d-531f-4763-8fba-fe756ad481f7/iso-2790-2004)

[https://standards.iteh.ai/catalog/standards/sist/fe382a5d-531f-4763-8fba-
fe756ad481f7/iso-2790-2004](https://standards.iteh.ai/catalog/standards/sist/fe382a5d-531f-4763-8fba-fe756ad481f7/iso-2790-2004)



PDF disclaimer

This PDF file may contain embedded typefaces. In accordance with Adobe's licensing policy, this file may be printed or viewed but shall not be edited unless the typefaces which are embedded are licensed to and installed on the computer performing the editing. In downloading this file, parties accept therein the responsibility of not infringing Adobe's licensing policy. The ISO Central Secretariat accepts no liability in this area.

Adobe is a trademark of Adobe Systems Incorporated.

Details of the software products used to create this PDF file can be found in the General Info relative to the file; the PDF-creation parameters were optimized for printing. Every care has been taken to ensure that the file is suitable for use by ISO member bodies. In the unlikely event that a problem relating to it is found, please inform the Central Secretariat at the address given below.

iTeh STANDARD PREVIEW
(standards.iteh.ai)

ISO 2790:2004

<https://standards.iteh.ai/catalog/standards/sist/fe382a5d-531f-4763-8fba-fe756ad481f7/iso-2790-2004>

© ISO 2004

All rights reserved. Unless otherwise specified, no part of this publication may be reproduced or utilized in any form or by any means, electronic or mechanical, including photocopying and microfilm, without permission in writing from either ISO at the address below or ISO's member body in the country of the requester.

ISO copyright office
Case postale 56 • CH-1211 Geneva 20
Tel. + 41 22 749 01 11
Fax + 41 22 749 09 47
E-mail copyright@iso.org
Web www.iso.org

Published in Switzerland

Contents

	Page
1 Scope	1
2 Normative references	1
3 Terms, definitions and symbols	1
4 Belts	1
4.1 General	1
4.2 Cross-section and pitch zone	1
4.3 Measurement of the effective length of a belt and its ride-out	2
4.4 Centre distance variations	4
5 Service pulleys	4
5.1 Dimensions	4
5.2 Checking of effective diameter	6
5.3 Designation	7

iTeh STANDARD PREVIEW (standards.iteh.ai)

[ISO 2790:2004](https://standards.iteh.ai/catalog/standards/sist/fe382a5d-531f-4763-8fba-fe756ad481f7/iso-2790-2004)

[https://standards.iteh.ai/catalog/standards/sist/fe382a5d-531f-4763-8fba-
fe756ad481f7/iso-2790-2004](https://standards.iteh.ai/catalog/standards/sist/fe382a5d-531f-4763-8fba-fe756ad481f7/iso-2790-2004)

Foreword

ISO (the International Organization for Standardization) is a worldwide federation of national standards bodies (ISO member bodies). The work of preparing International Standards is normally carried out through ISO technical committees. Each member body interested in a subject for which a technical committee has been established has the right to be represented on that committee. International organizations, governmental and non-governmental, in liaison with ISO, also take part in the work. ISO collaborates closely with the International Electrotechnical Commission (IEC) on all matters of electrotechnical standardization.

International Standards are drafted in accordance with the rules given in the ISO/IEC Directives, Part 2.

The main task of technical committees is to prepare International Standards. Draft International Standards adopted by the technical committees are circulated to the member bodies for voting. Publication as an International Standard requires approval by at least 75 % of the member bodies casting a vote.

Attention is drawn to the possibility that some of the elements of this document may be the subject of patent rights. ISO shall not be held responsible for identifying any or all such patent rights.

ISO 2790 was prepared by Technical Committee ISO/TC 41, *Pulleys and belts (including veebelts)*, Subcommittee SC 1, *Friction*.

This fourth edition cancels and replaces the third edition (ISO 2790:1989), subclauses 4.1, 4.2 and 5.1, Tables 1, 2, 4 and 5, of which have been technically revised and a new Figure 5 added.

ISO 2790:2004
<https://standards.iteh.ai/catalog/standards/sist/fe382a5d-531f-4763-8fba-fe756ad481f7/iso-2790-2004>

Belt drives — V-belts for the automotive industry and corresponding pulleys — Dimensions

1 Scope

This International Standard specifies the requirements for belts and pulleys for V-belt drives used for driving auxiliaries of internal combustion engines for the automotive industry.

2 Normative references

The following referenced documents are indispensable for the application of this document. For dated references, only the edition cited applies. For undated references, the latest edition of the referenced document (including any amendments) applies.

ISO 1081, *Belt drives — V-belts and V-ribbed belts, and corresponding grooved pulleys — Vocabulary*

ISO 8370-1:1993, *Belt drives — Dynamic test to determine pitch zone location — Part 1: V-belts*

ISO 9608, *V-belts — Uniformity of belts — Test method for determination of centre distance variation*

3 Terms, definitions and symbols

For the purposes of this document, the terms, definitions and symbols relating to drives using V-belts (i.e. belts and grooved pulleys) defined in ISO 1081 apply.

4 Belts

4.1 General

A belt is defined by its cross-section (groove profile AV 10 to AV 17) and by its effective length, in millimetres, measured under specified conditions.

4.2 Cross-section and pitch zone

A cross-section of a belt is defined by the nominal top width, w (see Figure 1 and Table 1).

The position of the belt pitch zone in the pulley groove is defined by the effective line differential, b_e (see Figure 4 and Table 1).

The nominal belt included angle is 40° unless agreed otherwise between customer and belt manufacturer.

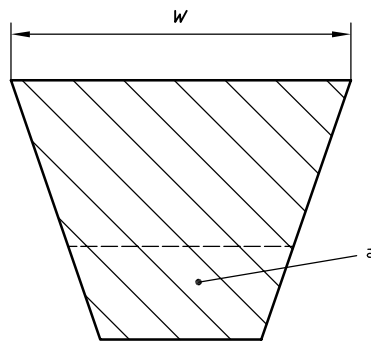

^a Notched (optional).

Figure 1 — Profile of the belt

Table 1 — Dimensions of belt cross-sections

Dimensions in millimetres

Parameter	Symbol	AV 10		AV 13		AV 17	
		Wrapped belt	Raw-edged belt	Wrapped belt	Raw-edged belt	Wrapped belt	Raw-edged belt
Nominal top width	<i>w</i>	10	10	13	13	17	17
Effective line differential	<i>b_e</i>	^a	^a	^a	^a	^a	^a

^a Values of *b_e* for the different types of belt are not standardized. They can be determined in accordance with ISO 8370-1:1993, 7.2.

4.3 Measurement of the effective length of a belt and its ride-out

Set the belt up on two identical pulleys, having the dimensions shown in Table 2 and mounted on a horizontal bench, and apply to the sliding pulley the measurement tension *F* (see Figure 2).

Rotate the belt at least twice to seat it properly.

The effective length of the belt, *L_e*, is given by the equation:

$$L_e = E_{max} + E_{min} + C_e$$

where

E_{max} is the measured maximum centre distance of the pulleys;

E_{min} is the measured minimum centre distance of the pulleys;

C_e is the effective circumference of one pulley:

$$C_e = \pi d_e = 300 \text{ mm}$$

The ride-out, *f*, of the belt (see Figure 3) shall be such that:

$$0 < f < 2,4 \text{ mm}$$

for each type of belt.

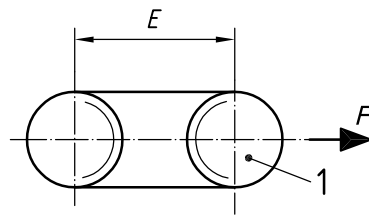

Key

1 sliding pulley

Figure 2 — Measuring device

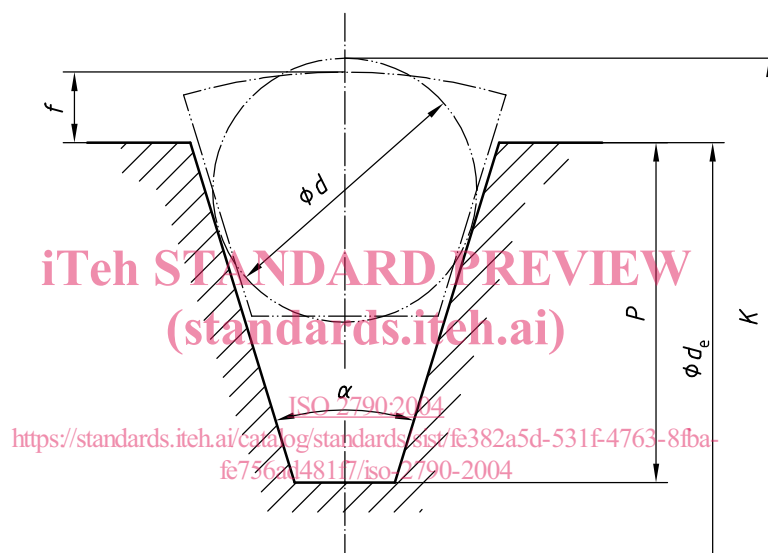

Figure 3 — Groove for measuring V-belts

Table 2 — Dimensions of checking pulley and measuring force

Parameter	Symbol	Unit	Groove profiles		
			AV 10	AV 13	AV 17
Groove angle	α	degrees	$36^\circ \pm 0^\circ 10'$	$36^\circ \pm 0^\circ 10'$	$34^\circ \pm 0^\circ 10'$
Effective diameter	d_e	mm	95,49	95,49	95,49
Outside diameter	d_o	mm	$95,5 \pm 0,2$	$95,5 \pm 0,2$	$95,5 \pm 0,2$
Diameter of balls or rods for checking the pulley grooves	d	mm	$7,95_{-0,025}^0$	$11,124_{-0,025}^0$	$14,288_{-0,025}^0$
Distance from external tangent planes to ball or rods	K	mm	$99,31 \pm 0,05$	$103,53 \pm 0,05$	$103,71 \pm 0,05$
Minimum depth of groove	P	mm	11	13,75	16
Tension ^a	F	N	267	267	356

^a The tension on each strand of the belt shall be equal to one half of the values shown.

4.4 Centre distance variations

Centre distance variations are given in relation to the belt top width given in Table 3. They are determined in accordance with ISO 9608.

Table 3 — Centre distance variations

Dimensions in millimetres

Belt length		Top width
Over	Up to (inclusive)	$w \leq 25$
		ΔE
—	1 000	1,2
1 000	2 000	1,6
2 000	5 000	2
5 000	—	2,5

5 Service pulleys

5.1 Dimensions

The dimensions of service pulleys are shown in Figures 4 and 5 and given in Tables 4 and 5.

The demands of modern accessory drives often make it necessary to use belts in sets. The dimensions of the grooves and groove spacings shown are for multiple belt drives or drives using joined belts.

(standards.iteh.ai)

Tolerances of axial and radial run-out in millimetres

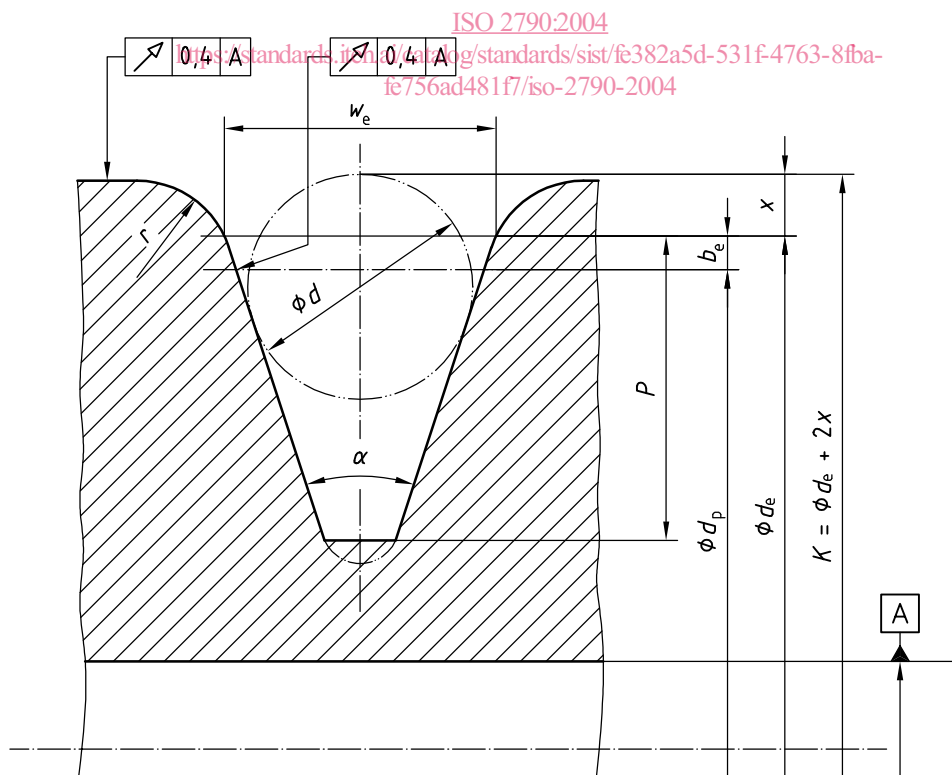

Key
 d_p is the pitch diameter

Figure 4 — Groove for service pulley

Table 4 — Dimensions of grooved pulleys

Dimensions in millimetres, angles in degrees

Parameter	Symbol	Groove profiles		
		AV 10	AV 13	AV 17
Effective width of groove	w_e	9,7	12,7	16,8
Groove angle ^a	α	$36^\circ \pm 0^\circ 30'$	$36^\circ \pm 0^\circ 30'$	$36^\circ \pm 0^\circ 30'$
Minimum groove depth	P	11	13,75	16
Minimum curved radius of sides at top of groove	r	0,8	0,8	0,8

The sides of the groove shall be smooth.

The axial and radial run-outs shall be measured separately as the total indicator reading of the movement of the ball mounted under spring pressure, to follow the groove as the pulley is rotated.

The optional bottom corner radii, if used, shall be below the depth P .

The axis of symmetry of any cross-section of the groove shall make an angle of 90° , with a maximum deviation of 2° , with a half-plane passing through the axis of the pulley.

^a For pulley diameters less than 57 mm, 70 mm and 102 mm respectively for AV 10, AV 13 and AV 17, it is recommended that the groove angle be reduced to 34° .

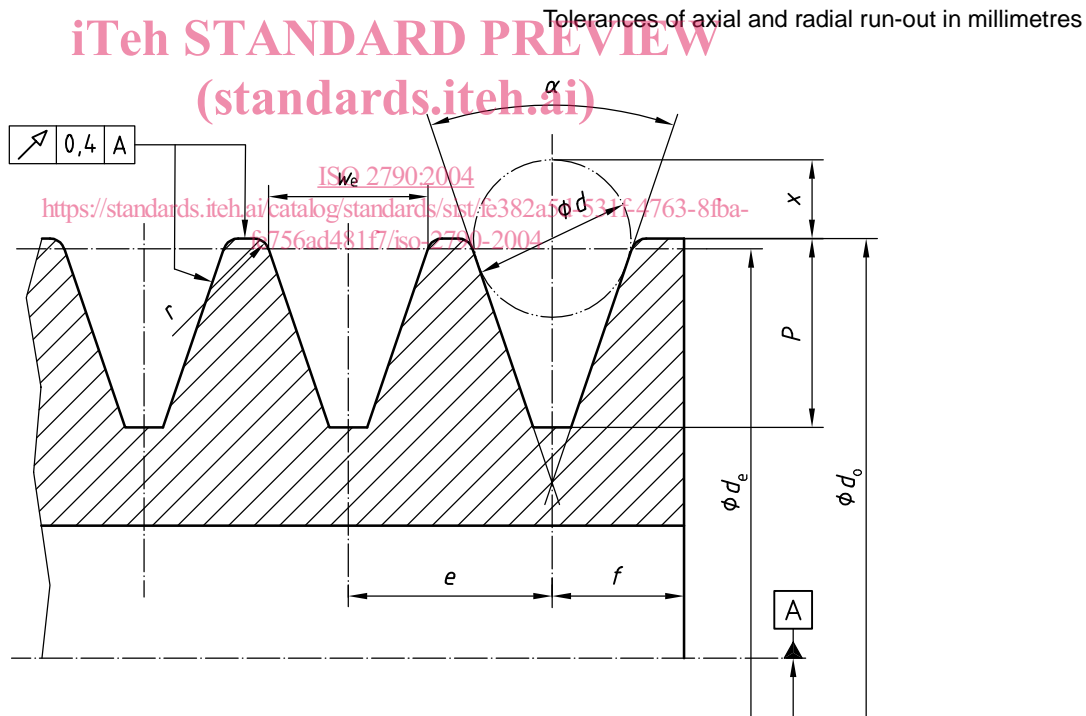

$$d_o - d_e \leq 1,4 \text{ mm}$$

Figure 5 — Multigrooved pulleys