



Standard Test Method for Dust-and-Fog Tracking and Erosion Resistance of Electrical Insulating Materials¹

This standard is issued under the fixed designation D 2132; the number immediately following the designation indicates the year of original adoption or, in the case of revision, the year of last revision. A number in parentheses indicates the year of last reapproval. A superscript epsilon (ϵ) indicates an editorial change since the last revision or reapproval.

1. Scope

1.1 This test method is intended to differentiate solid electrical insulating materials with respect to their resistance to the action of electric arcs produced by conduction through surface films of a specified contaminant containing moisture. Test Methods D 2302 and D 2303 may also be used to evaluate materials.

1.2 The values stated in inch-pound units are the standard, except in cases where SI units are more appropriate. The values in parentheses are for information only.

1.3 *This standard does not purport to address all of the safety concerns, if any, associated with its use. It is the responsibility of the user of this standard to establish appropriate safety and health practices and determine the applicability of regulatory limitations prior to use.* Specific precautionary statements are given in 11.4.

NOTE 1—There is no equivalent ISO standard.

2. Referenced Documents

2.1 ASTM Standards:

D 374 Test Methods for Thickness of Solid Electrical Insulation²

D 709 Specification for Laminated Thermosetting Materials²

D 1711 Terminology Relating to Electrical Insulation²

D 2302 Method of Test for Differential Wet Tracking Resistance of Electrical Insulating Materials with Controlled Water-to-Metal Discharges³

D 2303 Test Methods for Liquid-Contaminant, Inclined-Plane Tracking and Erosion of Insulating Materials²

3. Terminology

3.1 Definitions:

3.1.1 For definitions pertinent to this test method see Terminology D 1711.

¹ This test method is under the jurisdiction of ASTM Committee D-9 on Electrical and Electronic Insulating Materials and is the direct responsibility of Subcommittee D09.18 on Solid Insulations, Non-Metallic Shieldings, and Coverings for Electrical and Telecommunications Wires and Cables.

Current edition approved Feb. 10, 1998. Published January 1999. Originally issued as D 2132 – 62. Last previous edition D 2132 – 89.

² *Annual Book of ASTM Standards*, Vol 10.01.

³ Discontinued, see 1982 *Annual Book of ASTM Standards*, Part 39.

4. Summary of Test Method

4.1 With electrodes mounted as shown in Fig. 1, coat test specimens with a synthetic dust and test in a chamber shown in Fig. 2. Direct a water spray at the test specimen. After the surface has been wetted, apply a 60-Hz voltage between the electrodes. Arcing occurs across localized high-resistance areas produced by nonuniform evaporation of the water from the contaminant. These arcs produce high temperatures in the underlying insulation with resultant carbonization of most organic materials. The carbonization concentrates the electric field. Further carbonization may occur in the direction of the field. In such cases, a carbon track is formed which spans the distance between the electrodes and causes failure. Materials that do not track may erode under the action of the arcing. Such erosion usually progresses from an upper electrode through the thickness of the specimen towards the underlying electrode.

4.2 Rate materials that track in terms of the time required to form a track between the electrodes.

4.3 Rate materials that do not track in terms of the time required to erode to failure.

4.4 Failure will be indicated when the current increases sufficiently to actuate an overcurrent device.

NOTE 2—The conditions of this test favor the formation of a track for several possible reasons. Most important, the continuous renewal of the conducting properties of the contaminant by the water spray allows a track to grow progressively over long periods of time.

5. Significance and Use

5.1 *Method*—Electrical insulation in service may fail as a result of tracking, erosion, or a combination of both, if it is exposed to high relative humidity and contamination environments. This is particularly true of organic insulations in outdoor applications where the surface of the insulation becomes contaminated by deposits of moisture and dirt, for example, coal dust or salt spray. This test method is an accelerated test that simulates extremely severe outdoor contamination. It is believed that the most severe conditions likely to be encountered in outdoor service in the United States will be relatively mild compared to the conditions specified in this test method.

5.2 *Test Results*—Materials can be classified by this test method as tracking-resistant, tracking-affected, or tracking-susceptible. The exact test values for these categories as they

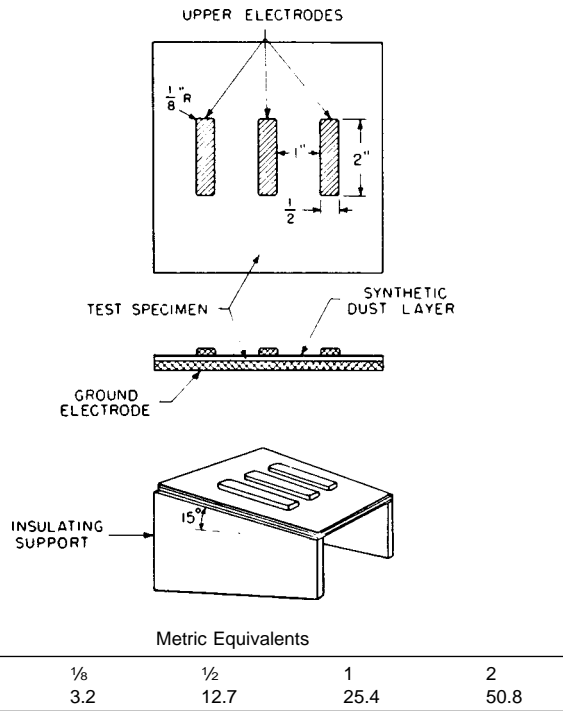

FIG. 1 Test Arrangement of Electrode System

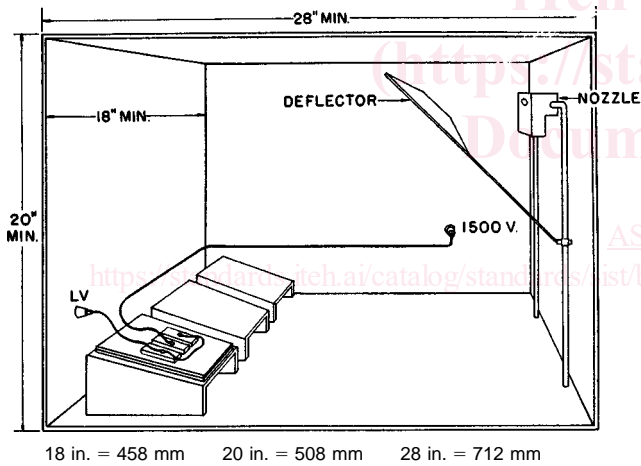

FIG. 2 Dust and Fog Test Chamber, Minimum Recommended Size

apply to specific uses will be specified in the appropriate material specifications, but guideline figures are suggested in Note 3. Tracking-resistant materials, unless erosion failure occurs first, may last many hundreds of hours (Note 4). Erosion, though it may progress laterally, generally results in a failure perpendicular to the specimen surface. Therefore, only specimens of the same nominal thickness may be compared for resistance to tracking-induced erosion. The extent of erosion may be estimated from measurements of the depth of penetration of the erosion. Materials that are not tracking-susceptible may be placed in three broad categories—erosion-resistant, erosion-affected, and erosion-susceptible. When the standard thickness specimen is tested, the following times to failure typify the categories (Note 5):

Erosion-susceptible	5 to 50 h
Erosion-affected	50 to 200 h
Erosion-resistant	over 200 h

NOTE 3—Tracking-susceptible materials usually fail within 5 h. Tracking-affected materials usually fail before about 100 h.

NOTE 4—This information is derived from the individual experiences of eight laboratories using this test method since its publication as a suggested test method in June 1957, and from the results of an organized test program among these laboratories.

NOTE 5—In a normal distribution approximately 68 % of all test values are included within ± 1 standard deviation of the mean.

5.3 *Interpretation of Test Results*—This test method provides information that allows classification as described in 5.2. The comparison of materials within the same group is likely to be ambiguous unless three or more replicate specimens are tested. When the test method is used for specification purposes, simple minimum values should not be established without consideration of the large variance to be expected in test results. It is recommended that quality levels and specification minima be determined by statistical techniques.

6. Apparatus

6.1 *General*—A schematic diagram of the power supply and control apparatus for testing one specimen is shown in Fig. 3(a). It is generally desirable to test three or more specimens simultaneously. It is recommended but not mandatory that a separate power supply and control be used for each test specimen. This allows “breaking-in” and recording of time to failure separately for each specimen.

6.2 *Circuit Breaker*—The circuit breaker (current relay, OL) interrupts the power supply on failure and stops the timing meter. It may be used as an ON-OFF switch and as a device for interrupting air and water supply when all specimens fail. Fig. 3(b) illustrates the air and water supply circuit when three specimens are tested using one fog nozzle. The circuit breaker shall be rated at 2 to 3 A, inverse-time element type, for a 115-V supply. Use a resistance, R_0 , to shunt the current coil during the break-in period so that the breaker will not actuate as a result of the bright-flash currents typical of this period. Adjust the resistance to produce an effective breaker action at approximately 6 A (115-V supply). Remove or switch out the shunt resistance after break-in.

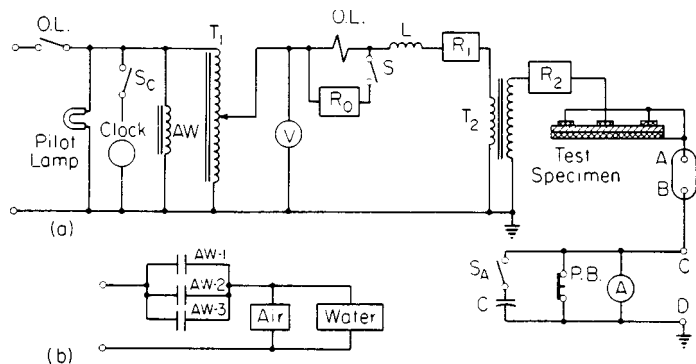

(a) Power supply and control circuit of wet tracking tests.
(b) Air and water supply circuit.

FIG. 3 Circuit Diagrams

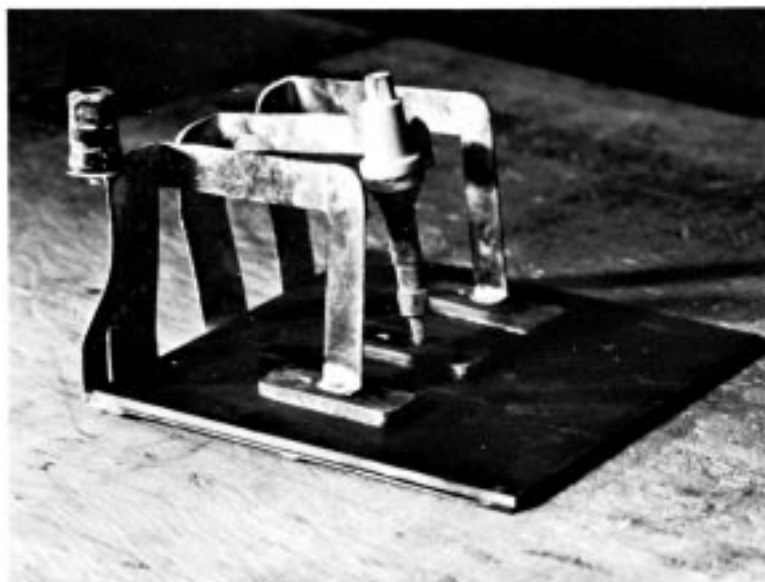

FIG. 4 Clamping Arrangement for Test-Specimen Electrodes

6.3 *Supply Transformer*⁴—Use a supply transformer, T_2 , capable of supplying 1500 V, 60 Hz, rms. A200-VA potential transformer is capable of supplying power for up to three specimens if desired. Use a transformer with a 20:1 ratio when used with a 115-V primary supply. Choose a transformer that offers an impedance between 600 and 1200 Ω resistance and 200 and 700 Ω reactance. Accomplish this by insertion of inductance L and resistance R_1 in the low-voltage side and resistance R_2 in the high-voltage side.

6.4 *Control Transformer*—Use a variable-ratio autotransformer, T_1 , to adjust the voltage as required.

6.5 *Voltmeter*—A voltmeter, V , may be used in the primary side to determine the specimen test voltage. Alternatively a high-impedance voltmeter may be connected in the secondary, in which case precautions should be taken to prevent electric shock to an operator. If a voltmeter is used in the primary, calibrate it against secondary voltage with a secondary load of 10 mA.

6.6 *Monitoring Provisions*— Use an ac ammeter, A , to monitor specimen current. Use a separate ammeter for each test specimen. Alternatively make provisions to connect an ammeter into each test-specimen circuit. Shunt the ammeter with a normally closed contact, PB , and a capacitance, C , to protect the ammeter from the large intermittent currents that occur during break-in. Connect the capacitance, if used, by a switch, S_A . After the break-in period, open the switch unless the values of the capacitance and ammeter impedances are such as to produce negligible error in current measurement. Use terminals A , B and C , D for oscilloscope monitoring, for current measurement with a voltmeter in combination with a resistor, or for insertion of an undercurrent relay to be used to stop the clock if the scintillation current falls below the specified value.

6.7 *Electrodes*—Use three copper or brass electrodes $\frac{1}{2}$ by 2 by $\frac{1}{8}$ in. (13 by 51 by 3.2 mm), with corners rounded to a

$\frac{1}{8}$ -in. (3.2-mm) radius on the top surface of the specimen and spaced 1 in. (25 mm) apart as shown in Fig. 1. Use a ground plate of copper or brass and of the same size as the test specimen on the bottom surface and mounted on an insulating support inclined 15 deg to the horizontal as shown in Fig. 1. Clamp the electrodes firmly to the test specimen. A suggested arrangement is shown in Fig. 4.

6.8 *Test Chamber*—Use a cubicle test chamber, Fig. 2, made from plastic or metal. The front wall is made of glass or poly(methyl methacrylate), or contains viewing ports or doors made of these materials. Make the cubicle at least 20 in. (510 mm) high and 28 in. (710 mm) wide. Determine the depth by the number of specimens to be tested. Three specimens require a minimum depth of 18 in. (460 mm). Fit the chamber with means for venting near the bottom of the cubicle, preferably along the end of the chamber where the specimens are located. Limit the venting area to about 20 in.² (130 cm²) to eliminate dependence of test results on the ambient humidity.

6.8.1 Mount one or more fog nozzles (Fig. 5) to obtain the specified uniform moisture deposition on all test specimens. It is suggested that one fog nozzle, mounted approximately 25 in. (635 mm) straight line distance from the nozzle to the center specimen at a height of approximately 14 in. (360 mm) above these specimens, will, with a suitably adjusted deflector, produce the specified conditions for three test specimens in a single cubicle (see Fig. 2). When only one fog nozzle is used in the cubicle, it is recommended that additional air be introduced into the cubicle equal to about double that flowing through a standard fog nozzle connected to an air supply of 5 to 6 psig (34 to 41 kPa).

6.8.2 Connect the fog nozzle assembly,⁵ Fig. 6, to an air and water supply. Provide means to adjust the air supply to 5 to 6 psig. Supply the water from a reservoir mounted below the

⁴ General Electric Type JE41, Model KAR-3, and Westinghouse Type VS, Style No. 687588, have been found satisfactory for this purpose.

⁵ A suitable fog nozzle is a Lucite atomizer, Model 145-718 manufactured by Industrial Filter and Pump Manufacturing Co., 5916 Ogden Ave., Chicago, IL 60650.(708-656-7800)