

SLOVENSKI STANDARD
SIST EN 3682-004:2014**01-april-2014****Nadomešča:****SIST EN 3682-004:2009**

Aeronavtika - Konektorji, vtič in vtičnica, električni, pravokotni, zamenljivi tip, s stojalom in ploščo, s stalno delovno temperaturo do 150 °C - 004. del: Vtičnica, velikost 2 - Standard za proizvod

Aerospace series - Connectors, plug and receptacle, electrical, rectangular, interchangeable insert type, rack to panel, operating temperature 150 °C continuous - Part 004: Size 2 receptacle - Product standard

Luft- und Raumfahrt - Elektrischer Rechtecksteckverbinder, freie und feste Bauform, auswechselbare Isolierkörper, Gestell-Einschubsteckverbinder, Betriebstemperatur 150 °C konstant - Teil 004: Steckdose Größe 2 - Produktnorm

Série aérospatiale - Connecteurs électriques rectangulaires rackables, fiches et embases, à inserts interchangeables, température d'utilisation 150 °C continu - Partie 004: Boîtier femelle taille 2 - Norme de produit

Ta slovenski standard je istoveten z: EN 3682-004:2012

ICS:

49.060	Letalska in vesoljska električna oprema in sistemi	Aerospace electric equipment and systems
--------	--	--

SIST EN 3682-004:2014**en**

iTeh STANDARD PREVIEW
(standards.iteh.ai)

[SIST EN 3682-004:2014](#)

<https://standards.iteh.ai/catalog/standards/sist/49f439bf-3443-434b-a743-3faefdaaf53/sist-en-3682-004-2014>

EUROPEAN STANDARD

EN 3682-004

NORME EUROPÉENNE

EUROPÄISCHE NORM

October 2012

ICS 49.060

Supersedes EN 3682-004:2006

English Version

**Aerospace series - Connectors, plug and receptacle, electrical,
rectangular, interchangeable insert type, rack to panel, operating
temperature 150 °C continuous - Part 004: Size 2 receptacle -
Product standard**

Série aérospatiale - Connecteurs électriques rectangulaires rackables, fiches et embases, à inserts interchangeables, température d'utilisation 150 °C continu - Partie 004: Boîtier femelle taille 2 - Norme de produit

Luft- und Raumfahrt - Elektrischer Rechtecksteckverbinder, freie und feste Bauform, auswechselbare Isolierkörper, Gestell-Einschubsteckverbinder, Betriebstemperatur 150 °C konstant - Teil 004: Fester Steckverbinder Größe 2 - Produktnorm

This European Standard was approved by CEN on 13 April 2012.

CEN members are bound to comply with the CEN/CENELEC Internal Regulations which stipulate the conditions for giving this European Standard the status of a national standard without any alteration. Up-to-date lists and bibliographical references concerning such national standards may be obtained on application to the CEN-CENELEC Management Centre or to any CEN member.

This European Standard exists in three official versions (English, French, German). A version in any other language made by translation under the responsibility of a CEN member into its own language and notified to the CEN-CENELEC Management Centre has the same status as the official versions.

CEN members are the national standards bodies of Austria, Belgium, Bulgaria, Croatia, Cyprus, Czech Republic, Denmark, Estonia, Finland, Former Yugoslav Republic of Macedonia, France, Germany, Greece, Hungary, Iceland, Ireland, Italy, Latvia, Lithuania, Luxembourg, Malta, Netherlands, Norway, Poland, Portugal, Romania, Slovakia, Slovenia, Spain, Sweden, Switzerland, Turkey and United Kingdom.



EUROPEAN COMMITTEE FOR STANDARDIZATION
COMITÉ EUROPÉEN DE NORMALISATION
EUROPÄISCHES KOMITEE FÜR NORMUNG

Management Centre: Avenue Marnix 17, B-1000 Brussels

Contents

Page

Foreword.....	3
1 Scope	4
2 Normative references	4
3 Terms and definitions	4
4 Required characteristics	4
5 Designation	9
6 Marking	9
7 Technical specification	9

iTeh STANDARD PREVIEW
(standards.iteh.ai)

[SIST EN 3682-004:2014](https://standards.iteh.ai/catalog/standards/sist/49f439bf-3443-434b-a743-3faefdaaf53/sist-en-3682-004-2014)

<https://standards.iteh.ai/catalog/standards/sist/49f439bf-3443-434b-a743-3faefdaaf53/sist-en-3682-004-2014>

Foreword

This document (EN 3682-004:2012) has been prepared by the Aerospace and Defence Industries Association of Europe - Standardization (ASD-STAN).

After enquiries and votes carried out in accordance with the rules of this Association, this Standard has received the approval of the National Associations and the Official Services of the member countries of ASD, prior to its presentation to CEN.

This European Standard shall be given the status of a national standard, either by publication of an identical text or by endorsement, at the latest by April 2013, and conflicting national standards shall be withdrawn at the latest by April 2013.

Attention is drawn to the possibility that some of the elements of this document may be the subject of patent rights. CEN [and/or CENELEC] shall not be held responsible for identifying any or all such patent rights.

This document supersedes EN 3682-004:2006.

According to the CEN/CENELEC Internal Regulations, the national standards organisations of the following countries are bound to implement this European Standard: Austria, Belgium, Bulgaria, Croatia, Cyprus, Czech Republic, Denmark, Estonia, Finland, Former Yugoslav Republic of Macedonia, France, Germany, Greece, Hungary, Iceland, Ireland, Italy, Latvia, Lithuania, Luxembourg, Malta, Netherlands, Norway, Poland, Portugal, Romania, Slovakia, Slovenia, Spain, Sweden, Switzerland, Turkey and the United Kingdom.

SIST EN 3682-004:2014

<https://standards.iteh.ai/catalog/standards/sist/49f439bf-3443-434b-a743-3faefedaa53/sist-en-3682-004-2014>

EN 3682-004:2012 (E)**1 Scope**

This European Standard defines the size 2 receptacle used in the family of rectangular electrical connectors for rack to panel, with interchangeable inserts. The plug corresponding to this receptacle is defined in EN 3682-005.

2 Normative references

The following documents, in whole or in part, are normatively referenced in this document and are indispensable for its application. For dated references, only the edition cited applies. For undated references, the latest edition of the referenced document (including any amendments) applies.

EN 3682-001, *Aerospace series — Connectors, plug and receptacle, electrical, rectangular, interchangeable insert type, rack to panel, operating temperature 150 °C continuous — Part 001: Technical specification*

EN 3682-002, *Aerospace series — Connectors, plug and receptacle, electrical, rectangular, interchangeable insert type, rack to panel, operating temperature 150 °C continuous — Part 002: Specification of performance and contact arrangements*

EN 3682-005, *Aerospace series — Connectors, plug and receptacle, electrical, rectangular, interchangeable insert type, rack to panel, operating temperature 150 °C continuous — Part 005: Size 2 plug — Product standard*

ISO 263, *ISO inch screw threads — General plan and selection for screws, bolts and nuts — Diameter range 0,06 to 6 in¹⁾*

ITeT STANDARD PREVIEW
(standards.iteh.ai)

3 Terms and definitions

SIST EN 3682-004:2014

For the purposes of this document, the terms and definitions given in EN 3682-001 apply.

<https://standards.iteh.ai/catalog/standards/sist/49e139bf-3443-434b-a743-31ae1daa1d5/sist-en-3682-004-2014>

4 Required characteristics**4.1 Dimensions**

See Figures 1 to 3.

1) Published by: ISO International International Standardisation Organisation <http://www.iso.org>

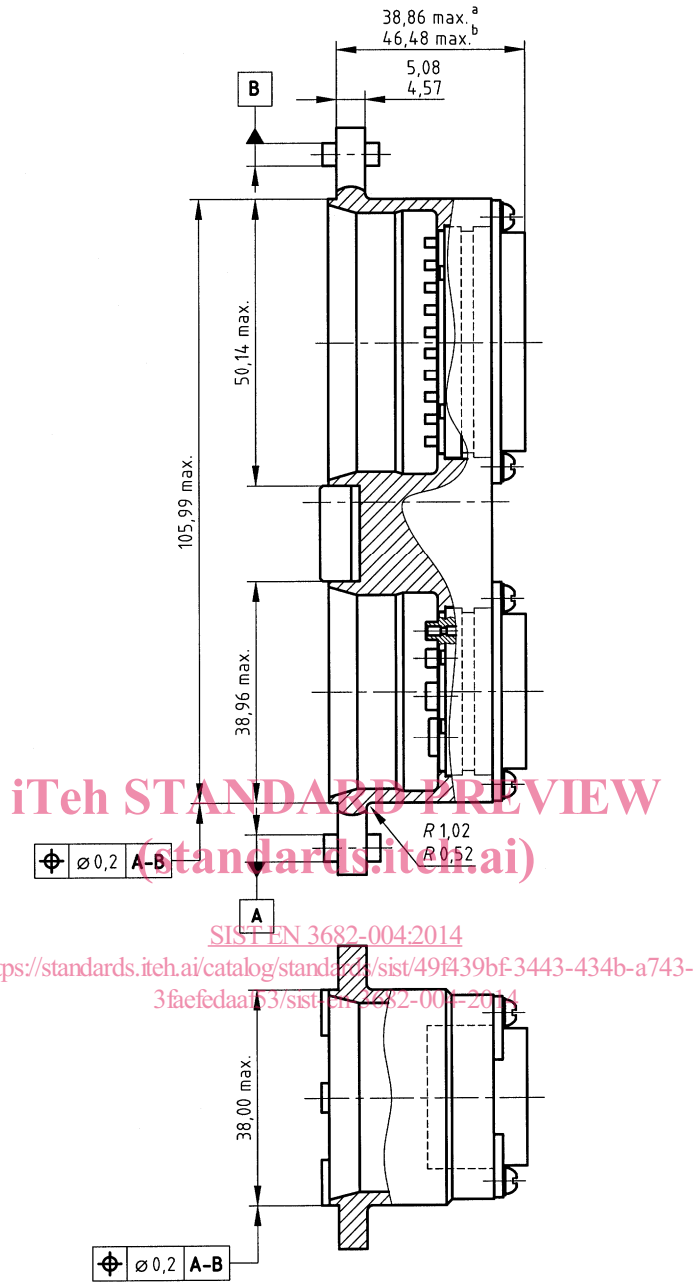

- ^a For arrangements with size 22 contacts.
- ^b For arrangements without size 22 contacts.

Figure 2

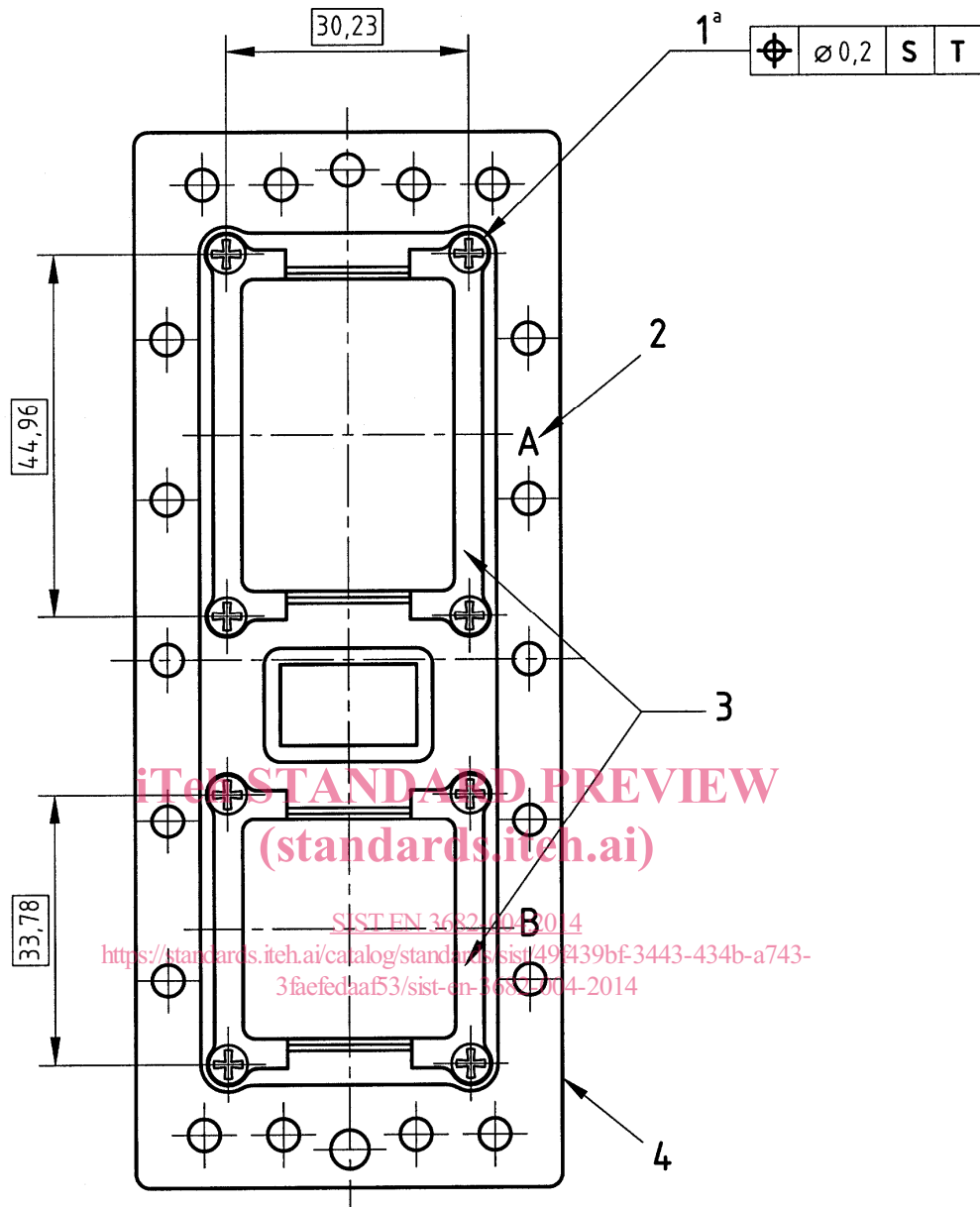

Key

- 1 Eight cross slotted screws 4-40 UNC 2A
- 2 Cavities identification on the front and the rear of the flange
- 3 Insert retention device
- 4 Marking of trademark of manufacture and part number on right or left of the flange

^a See ISO 263.

NOTE See EN 3682-001, Tables 2, 3 and 5 for S and T references.

Figure 3