**Road vehicles — Vehicle test methods for
electrical disturbances from narrowband
radiated electromagnetic energy —**

**Part 4:
Bulk current injection (BCI)**

iTeh STANDARD PREVIEW
*Véhicules routiers — Méthodes d'essai d'un véhicule soumis à des
perturbations électriques par rayonnement d'énergie électromagnétique
en bande étroite*
(standard.iteh.ai)

Partie 4: Méthode d'injection de courant (BCI)

ISO 11451-4:2006

<https://standards.iteh.ai/catalog/standards/sist/bf207974-8d70-4813-a2de-09913f0469f5/iso-11451-4-2006>



PDF disclaimer

This PDF file may contain embedded typefaces. In accordance with Adobe's licensing policy, this file may be printed or viewed but shall not be edited unless the typefaces which are embedded are licensed to and installed on the computer performing the editing. In downloading this file, parties accept therein the responsibility of not infringing Adobe's licensing policy. The ISO Central Secretariat accepts no liability in this area.

Adobe is a trademark of Adobe Systems Incorporated.

Details of the software products used to create this PDF file can be found in the General Info relative to the file; the PDF-creation parameters were optimized for printing. Every care has been taken to ensure that the file is suitable for use by ISO member bodies. In the unlikely event that a problem relating to it is found, please inform the Central Secretariat at the address given below.

iTeh STANDARD PREVIEW
(standards.iteh.ai)

[ISO 11451-4:2006](https://standards.iteh.ai/catalog/standards/sist/bf207974-8d70-4813-a2de-09913f0469f5/iso-11451-4-2006)

<https://standards.iteh.ai/catalog/standards/sist/bf207974-8d70-4813-a2de-09913f0469f5/iso-11451-4-2006>

© ISO 2006

All rights reserved. Unless otherwise specified, no part of this publication may be reproduced or utilized in any form or by any means, electronic or mechanical, including photocopying and microfilm, without permission in writing from either ISO at the address below or ISO's member body in the country of the requester.

ISO copyright office
Case postale 56 • CH-1211 Geneva 20
Tel. + 41 22 749 01 11
Fax + 41 22 749 09 47
E-mail copyright@iso.org
Web www.iso.org

Published in Switzerland

Foreword

ISO (the International Organization for Standardization) is a worldwide federation of national standards bodies (ISO member bodies). The work of preparing International Standards is normally carried out through ISO technical committees. Each member body interested in a subject for which a technical committee has been established has the right to be represented on that committee. International organizations, governmental and non-governmental, in liaison with ISO, also take part in the work. ISO collaborates closely with the International Electrotechnical Commission (IEC) on all matters of electrotechnical standardization.

International Standards are drafted in accordance with the rules given in the ISO/IEC Directives, Part 2.

The main task of technical committees is to prepare International Standards. Draft International Standards adopted by the technical committees are circulated to the member bodies for voting. Publication as an International Standard requires approval by at least 75 % of the member bodies casting a vote.

Attention is drawn to the possibility that some of the elements of this document may be the subject of patent rights. ISO shall not be held responsible for identifying any or all such patent rights.

ISO 11451-4 was prepared by Technical Committee ISO/TC 22, *Road vehicles*, Subcommittee SC 3, *Electrical and electronic equipment*.

This second edition cancels and replaces the first edition (ISO 11451-4:1995), which has been technically revised.

ISO 11451 consists of the following parts, under the general title *Road vehicles — Vehicle test methods for electrical disturbances from narrowband radiated electromagnetic energy*:

- *Part 1: General principles and terminology*
- *Part 2: Off-vehicle radiation sources*
- *Part 3: On-board transmitter simulation*
- *Part 4: Bulk current injection (BCI)*

iTeh STANDARD PREVIEW
(standards.iteh.ai)

ISO 11451-4:2006

<https://standards.iteh.ai/catalog/standards/sist/bf207974-8d70-4813-a2de-09913f0469f5/iso-11451-4-2006>

Road vehicles — Vehicle test methods for electrical disturbances from narrowband radiated electromagnetic energy —

Part 4: Bulk current injection (BCI)

1 Scope

This part of ISO 11451 specifies bulk current injection (BCI) test methods for testing the electromagnetic immunity of electronic components for passenger cars and commercial vehicles regardless of the propulsion system (e.g. spark-ignition engine, diesel engine, electric motor). The electromagnetic disturbance considered in this part of ISO 11451 is limited to continuous narrowband electromagnetic fields.

Part 1 of ISO 11451 gives definitions, practical use and basic principles of the test methods.

2 Normative references

The following referenced documents are indispensable for the application of this document. For dated references, only the edition cited applies. For undated references, the latest edition of the referenced document (including any amendments) applies.

ISO 11451-1:2005, *Road vehicles — Vehicle test methods for electrical disturbances from narrowband radiated electromagnetic energy — Part 1: General principles and terminology*

3 Test conditions

The applicable frequency range for this test method is 1 MHz to 400 MHz. The frequency range of the BCI test method is a direct function of the current probe characteristics. More than one type of current probe may be required to cover the Applicable frequency range.

The users shall specify the test severity level(s) over the frequency range. Suggested test severity levels are given in Annex C. These test severity levels are expressed in terms of the equivalent root-mean-square value of the unmodulated wave.

Standard test conditions are given in ISO 11451-1 for the following:

- test temperature,
- supply voltage,
- modulation,
- dwell time,

- frequency step sizes,
- definition of test severity levels, and
- test signal quality.

4 Test instrument description and specification

4.1 BCI system

BCI is a method of carrying out immunity tests by inducing disturbance signals directly into the wiring harness by means of a current injection probe. The injection probe is a current transformer through which the wires of the device under test (DUT) are passed. Immunity tests are then carried out by varying the test severity level and frequency of the induced disturbance.

BCI shall be conducted on each individual system fitted to the vehicle.

4.2 Instrumentation

Figure 1 shows an example of a BCI test configuration.

An injection probe or set of probes capable of operating over the test frequency range is required to interface the test equipment of the DUT. The probe shall be capable of withstanding a continuous input power over the test frequency range regardless of the system loading.

The current measurement probe or set of probes shall be capable of operating over the test frequency range. The current measurement probe(s) shall be terminated in the load impedance at which they are calibrated.

[ISO 11451-4:2006](https://standards.iteh.ai/catalog/standards/sist/bf207974-8d70-4813-a2de-09913f0469f5/iso-11451-4-2006)

4.3 Test set-up

<https://standards.iteh.ai/catalog/standards/sist/bf207974-8d70-4813-a2de-09913f0469f5/iso-11451-4-2006>

The vehicle should be tested as built; no additional grounding connections are allowed. Tests should be performed inside a shielded room.

The distance between the vehicle and all other conductive structures, such as the walls of a shielded room (with the exception of the ground plane underneath the vehicle) shall be a minimum of 0,5 m.

5 Test procedure

5.1 Test plan

Prior to performing the tests, a test plan shall be prepared; it shall include interface test points, mode of operation for the DUT, acceptance criteria for the DUT, and any special instructions and changes from the standard test. Each DUT shall be verified under the most significant conditions, i.e. at least in stand-by mode and in a mode where all the actuators can be excited.

5.2 Test methods

CAUTION — Hazardous voltages and fields may exist within the test area. Care shall be taken to ensure that the requirements for limiting the exposure of humans to RF energy are met.

There are two test methods for the BCI test: the Substitution method and the Closed-loop method (see 5.2.1 and 5.2.2 respectively).

For both tests, the test equipment shall be connected in a manner similar to that shown in Figure 1.

Dimensions in millimetres

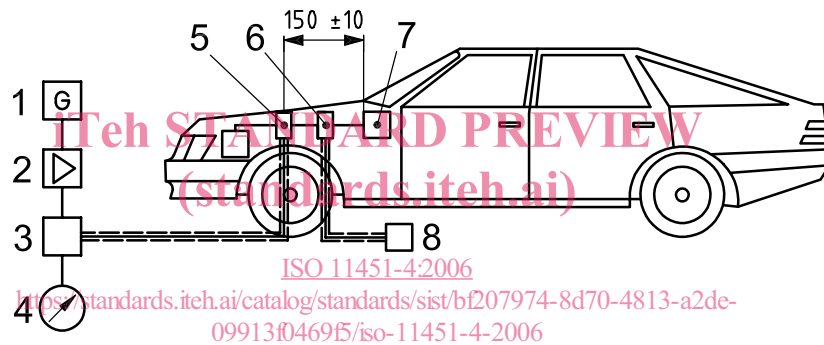

Key

- 1 signal generators
- 2 broadband amplifier
- 3 RF 50 Ω directional coupler
- 4 RF power level measuring device or equivalent
- 5 RF injection probe
- 6 RF current measurement probe (required for Closed-loop method, optional for Substitution method)
- 7 DUT
- 8 spectrum analyser or equivalent (required for Closed-loop method, optional for Substitution method)

NOTE It is recommended that appropriate ferrite chokes be placed on the coaxial cables to the injection and current measurement probes.

Figure 1 — Example of BCI test configuration

5.2.1 Substitution method

This method is based upon the use of forward power as the reference parameter for calibration and test.

In this method, the specific test level (current, voltage or power) shall be calibrated prior to the actual testing.

The test with the DUT is then conducted by subjecting it to the test signals based on the calibrated values as predetermined in the test plan.

Measurements using this method can be affected by coupling between the injection probe and the wiring harness as well as by reflected energy.

Mount the current injection probe around the harness (150 ± 10) mm from the connector or the outlet aperture of the DUT being tested on the vehicle.

Where the harness contains a number of branches to a DUT, the test should be repeated with the current probe(s) clamped around each of the branches (150 ± 10) mm from the branch termination. Under these test conditions, the measuring probe, if used, shall be left at its previous distance from the DUT.

Using the pre-calibrated level of forward power (see Annex A), conduct a search for events over the frequency range of the injection probe.

For each event, record the lowest forward power to the probe as the threshold of immunity even if this is found with the injection probe in different positions at different frequencies.

A current measurement probe may optionally be mounted between the current injection probe and the DUT. It may provide extra useful information but it may also modify the test conditions. Where this probe is used, the measured current cannot be used to determine the performance of the DUT, but should be retained and used during investigative work for the causes of events and the variances in test conditions after system modifications.

5.2.2 Closed-loop method

iTeh STANDARD PREVIEW

(standards.iteh.ai)

The RF to the current injection probe shall be increased until:

- the predetermined maximum test current level, measured using the current measurement probe, is reached, or
- the maximum forward power (defined in the test plan) to the injection probe is achieved.

The current measurement probe shall be calibrated using the method in Annex B.

Record the threshold of susceptibility as a function of frequency.

5.3 Test report

When required in the test plan, a test report shall be submitted detailing information regarding the test equipment, test site, systems tested, frequencies, power levels, system interactions and any other relevant information regarding the test.

Annex A (normative)

Current injection probe calibration method

To determine the injected current flowing, the forward power measurement across a calibration fixture is used. Figure A.1 shows an example of a test equipment configuration for the current injection probe calibration.

Mount the current injection probe centred in the calibration fixture (see Figure A.2), and while sweeping the test frequency range, monitor the forward power required to achieve the current at which testing is to be conducted.

As an alternative method, once testing of the system is complete and all data has been recorded, mount the current injection probe in the calibration fixture. At each frequency showing an event, the recorded forward power levels are applied to the probe. The currents then observed in the calibration fixture are those at which events within the system occurred.

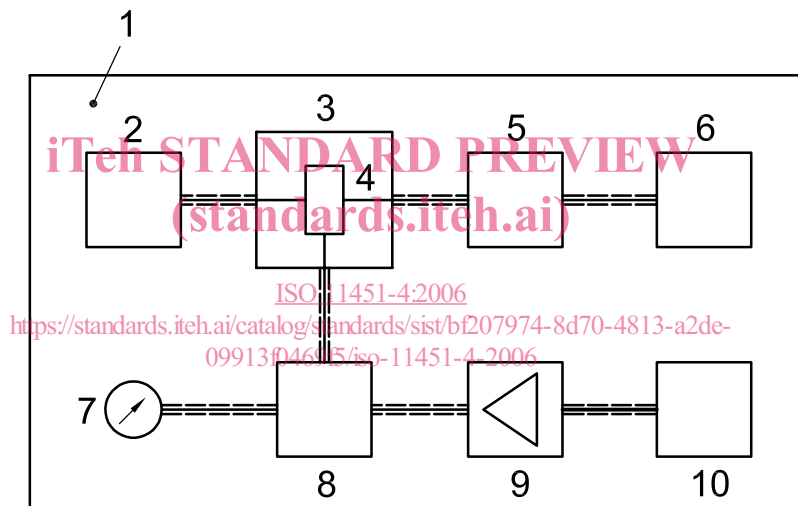

Key

- 1 shielded enclosure
- 2 50 Ω coaxial load, VSWR 1,2:1 max
- 3 calibration fixture
- 4 injection probe
- 5 50 Ω attenuator
- 6 spectrum analyser or equivalent
- 7 RF power level measuring device (two are required)
- 8 RF 50 Ω dual directional coupler (with 30 dB minimum decoupling coefficient)
- 9 broadband amplifier with 50 Ω output impedance
- 10 RF signal generator

Figure A.1 — Example of current injection probe calibration configuration