

---

---

**Agricultural machinery — Safety —  
Part 5:  
Power-driven soil-working machines**

*Matériel agricole — Sécurité —*

*Partie 5: Machines de travail du sol à outils animés*

**iTeh STANDARD PREVIEW**  
**(standards.iteh.ai)**

[ISO 4254-5:2008](https://standards.iteh.ai/catalog/standards/sist/254b9d5b-7ebc-4019-bdca-4e1ffddb668e/iso-4254-5-2008)

<https://standards.iteh.ai/catalog/standards/sist/254b9d5b-7ebc-4019-bdca-4e1ffddb668e/iso-4254-5-2008>



**PDF disclaimer**

This PDF file may contain embedded typefaces. In accordance with Adobe's licensing policy, this file may be printed or viewed but shall not be edited unless the typefaces which are embedded are licensed to and installed on the computer performing the editing. In downloading this file, parties accept therein the responsibility of not infringing Adobe's licensing policy. The ISO Central Secretariat accepts no liability in this area.

Adobe is a trademark of Adobe Systems Incorporated.

Details of the software products used to create this PDF file can be found in the General Info relative to the file; the PDF-creation parameters were optimized for printing. Every care has been taken to ensure that the file is suitable for use by ISO member bodies. In the unlikely event that a problem relating to it is found, please inform the Central Secretariat at the address given below.

**iTeh STANDARD PREVIEW**  
**(standards.iteh.ai)**

[ISO 4254-5:2008](https://standards.iteh.ai/catalog/standards/sist/254b9d5b-7ebc-4019-bdca-4e1fdddb668e/iso-4254-5-2008)

<https://standards.iteh.ai/catalog/standards/sist/254b9d5b-7ebc-4019-bdca-4e1fdddb668e/iso-4254-5-2008>



**COPYRIGHT PROTECTED DOCUMENT**

© ISO 2008

All rights reserved. Unless otherwise specified, no part of this publication may be reproduced or utilized in any form or by any means, electronic or mechanical, including photocopying and microfilm, without permission in writing from either ISO at the address below or ISO's member body in the country of the requester.

ISO copyright office  
Case postale 56 • CH-1211 Geneva 20  
Tel. + 41 22 749 01 11  
Fax + 41 22 749 09 47  
E-mail [copyright@iso.org](mailto:copyright@iso.org)  
Web [www.iso.org](http://www.iso.org)

Published in Switzerland

## Contents

Page

Foreword .....	iv
Introduction.....	v
1 Scope .....	1
2 Normative references .....	1
3 Terms and definitions .....	2
4 Safety requirements and/or measures .....	2
4.1 General .....	2
4.2 Noise reduction at the design stage.....	2
4.3 Protection against inadvertent contact with power-driven tools .....	2
4.4 Adjustment of working depth.....	7
5 Verification of safety requirements or protective measures .....	9
6 Information for use .....	9
6.1 Operator's manual .....	9
6.2 Safety and instructional signs .....	9
Annex A (informative) List of significant hazards .....	10
Annex B (informative) Examples of power-driven soil working machines .....	14

[ISO 4254-5:2008](https://standards.iteh.ai/catalog/standards/sist/254b9d5b-7ebc-4019-bdca-4e1ffddb668e/iso-4254-5-2008)

<https://standards.iteh.ai/catalog/standards/sist/254b9d5b-7ebc-4019-bdca-4e1ffddb668e/iso-4254-5-2008>

## Foreword

ISO (the International Organization for Standardization) is a worldwide federation of national standards bodies (ISO member bodies). The work of preparing International Standards is normally carried out through ISO technical committees. Each member body interested in a subject for which a technical committee has been established has the right to be represented on that committee. International organizations, governmental and non-governmental, in liaison with ISO, also take part in the work. ISO collaborates closely with the International Electrotechnical Commission (IEC) on all matters of electrotechnical standardization.

International Standards are drafted in accordance with the rules given in the ISO/IEC Directives, Part 2.

The main task of technical committees is to prepare International Standards. Draft International Standards adopted by the technical committees are circulated to the member bodies for voting. Publication as an International Standard requires approval by at least 75 % of the member bodies casting a vote.

Attention is drawn to the possibility that some of the elements of this document may be the subject of patent rights. ISO shall not be held responsible for identifying any or all such patent rights.

ISO 4254-5 was prepared by Technical Committee ISO/TC 23, *Tractors and machinery for agriculture and forestry*, Subcommittee SC 3, *Safety and comfort*.

This second edition cancels and replaces the first edition (ISO 4254-5:1992), which has been technically revised.

ISO 4254 consists of the following parts, under the general title *Agricultural machinery — Safety:*

- *Part 1: General requirements*
- *Part 3: Tractors* <sup>1)</sup>
- *Part 5: Power-driven soil-working machines*
- *Part 6: Sprayers and liquid fertilizer distributors*
- *Part 7: Combine harvesters, forage harvesters and cotton harvesters*
- *Part 8: Solid fertilizer distributors*
- *Part 9: Seed drills*
- *Part 10: Rotary tedders and rakes*
- *Part 11: Pick-up balers*
- *Part 12: Rotary mowers and flail mowers*

Part 4, *Forestry winches*, was cancelled and replaced by ISO 19472, *Machinery for forestry — Winches — Dimensions, performance and safety*.

---

1) To be cancelled and replaced by ISO 26322-1, *Tractors and machinery for agriculture and forestry — Safety — Part 1: Standard tractors*

## Introduction

The structure of safety standards in the field of machinery is as follows.

- a) Type-A standards (basis standards) give basic concepts, principles for design, and general aspects that can be applied to machinery.
- b) Type-B standards (generic safety standards) deal with one or more safety aspect(s) or one or more type(s) of safeguards that can be used across a wide range of machinery:
  - type-B1 standards on particular safety aspects (e.g. safety distances, surface temperature, noise);
  - type-B2 standards on safeguards (e.g. two-hands controls, interlocking devices, pressure sensitive devices, guards);
- c) Type-C standards (machinery safety standards) deal with detailed safety requirements for a particular machine or group of machines.

This part of ISO 4254 is a type-C standard as stated in ISO 12100-1.

When provisions of this type-C standard are different from those which are stated in type-A or type-B standards, the provisions of this type-C standard take precedence over the provisions of the other standards for machines that have been designed and built according to the provisions of this type-C standard.

The machinery concerned and the extent to which hazards, hazardous situations and events are covered are indicated in the scope of this part of ISO 4254. These hazards are specific to power-driven soil-working machines.

Significant hazards that are common to all the agricultural machines (self-propelled, mounted, semi-mounted and trailed) are dealt with in ISO 4254-1.

**iTeh STANDARD PREVIEW**  
**(standards.iteh.ai)**

ISO 4254-5:2008

<https://standards.iteh.ai/catalog/standards/sist/254b9d5b-7ebc-4019-bdca-4e1ffddb668e/iso-4254-5-2008>

# Agricultural machinery — Safety —

## Part 5: Power-driven soil-working machines

### 1 Scope

This part of ISO 4254, intended to be used together with ISO 4254-1, specifies the safety requirements and their verification for the design and construction of mounted, semi-mounted and trailed power-driven soil-working machines used in agriculture. In addition, it specifies the type of information on safe working practices (including residual risks) to be provided by the manufacturer.

This part of ISO 4254 deals with significant hazards (as listed in Annex A), hazardous situations and events relevant to power-driven soil-working machines used as intended and under the conditions foreseen by the manufacturer (see Clause 4).

This part of ISO 4254 is not applicable to:

— spading machines;

— machines fitted with a retractable device making them capable of working between two successive plants in the same row.

This part of ISO 4254 is not applicable to environmental hazards or electromagnetic compatibility. It is not applicable to hazards related to moving parts for power transmission, except for strength requirements for guards and barriers, nor to maintenance or repairs carried out by professional service personnel.

NOTE 1 Specific requirements related to road traffic regulations are not taken into account in this part of ISO 4254.

NOTE 2 Vibrations are not regarded as a significant hazard in the case of mounted, semi-mounted or trailed machines.

This part of ISO 4254 is not applicable to power-driven soil-working machines which are manufactured before the date of its publication.

When requirements of this part of ISO 4254 are different from those which are stated in ISO 4254-1, the requirements of this part of ISO 4254 take precedence over the requirements of ISO 4254-1.

### 2 Normative references

The following referenced documents are indispensable for the application of this document. For dated references, only the edition cited applies. For undated references, the latest edition of the referenced document (including any amendments) applies.

ISO 4254-1:2008, *Agricultural machinery — Safety — Part 1: General requirements*

ISO 12100-1:2003, *Safety of machinery — Basic concepts, general principles for design — Part 1: Basic terminology, methodology*

### 3 Terms and definitions

For the purposes of this document, the terms and definitions given in ISO 12100-1 and ISO 4254-1 and the following apply.

**3.1 power-driven soil-working machine**  
machine with powered tools designed for modifying soil structure or profile and/or for incorporating plant and crop residues or animal manure during tillage

NOTE See Annex B for examples of such machines.

**3.2 attachment**  
equipment which can be fitted to a power-driven soil-working machine and which allows the function of the machine to be modified

**3.2.1 attachment preventing access**  
attachment which restricts access onto the top of the power-driven soil-working machine and its driven tools at the rear

EXAMPLE Seed drills.

**3.2.2 attachment not preventing access**  
equipment which allows access onto the top of the power-driven soil-working machine

EXAMPLE Frames, rollers or harrows.

ITeH STANDARD PREVIEW  
(standards.iteh.ai)

[ISO 4254-5:2008](https://standards.iteh.ai/standards/sist/254b9d5b-7ebc-4019-bdca-4e1ffddb668e/iso-4254-5-2008)

## 4 Safety requirements and/or measures

### 4.1 General

Machinery shall comply with the safety requirements and/or protective measures of this clause. Unless otherwise specified in this part of ISO 4254, the machine shall comply with the requirements of ISO 4254-1.

The compliance with the safety requirements and/or measures shall be verified in accordance with Clause 5.

### 4.2 Noise reduction at the design stage

The main noise sources when operating power-driven mounted, semi-mounted and trailed soil-working machines are the tractor, the engagement of tools with the soil — neither of which is under the control of the machine manufacturer — and the gearbox of the machine. Appropriately designed gearwheels, drives and oil bath lubrication and cooling may be seen as measures for noise reduction at the design stage.

### 4.3 Protection against inadvertent contact with power-driven tools

**4.3.1** Machines shall be designed or guarded in accordance with 4.3.1.1 to 4.3.1.5 in order to avoid inadvertent contact with the powered tools at the front, rear, sides and top of the machine during normal operation and service.

**4.3.1.1** At the front, sides and rear of the accessible zone shown in Figure 1, a barrier shall extend from the outermost path of the tools to a distance,  $a$ , beyond the path of the tools as shown in Figure 2 a) and b).

**4.3.1.2** On the top of the machine, the area between the barriers shall be guarded as follows.

a) The area covering the tools up to the outermost points of their path shall be guarded by a solid guard.



- b) The area between the barriers and the edge of the top guard shall be covered in such a way that it is not possible to gain access to the tools. This guarding may be achieved by a guard, any suitable part of the machine or a combination of both.

**4.3.1.3** On the sides and rear of the machine, when in the working position, for the guard covering the parts of the tools above the ground, distance  $a$  may extend to less than 200 mm (see Figure 3).

**4.3.1.4** At the rear of the machine when the guard is hinged, its lower edges shall be at a minimum distance,  $d$ , in any position, in accordance with the dimensions shown in Figure 4.

**4.3.1.5** The top guard, barriers and those parts of the machine ensuring the guarding shall be able to withstand a vertical downward load of 1 200 N. In addition, the barriers shall be capable of withstanding the following horizontal loads:

- a) 600 N for machines with a horizontal axis intended to be used with a tractor where the maximum power is  $\leq 37$  kW according to 6.1 h);
- b) 1 000 N for all other machines.

**4.3.2** The guard at the rear may be moveable or removable in order to permit the fitting of attachments. Attachments that afford equivalent protection to that provided by the rear guard may be used in place of the guard, provided that the following provisions are met.

- a) Such parts or such attachments shall not be power driven.
- b) Access to the driven tools shall be prevented by a barrier at any point on line ZY as shown in Figure 2 c). The area between the barrier and the top of the machine shall be covered in accordance with 4.3.1.2 b).
- c) When attachments preventing access (see 3.2.1) are fitted, it shall not be possible to gain access to the power-driven tools of the soil-working machine through the shaded area shown in Figure 5. This means that for attachments preventing access, the guarding at the rear according to 4.3.1.1 and 4.3.1.2 b) shall extend a minimum 550 mm from both sides of the machine.

**4.3.3** When a soil-working machine with powered tools can be used without machine components or tools normally serving as a guard according to 6.1 a) and b), the machine shall be designed in such a way that an alternative guard (supplied by the manufacturer) can be fitted.

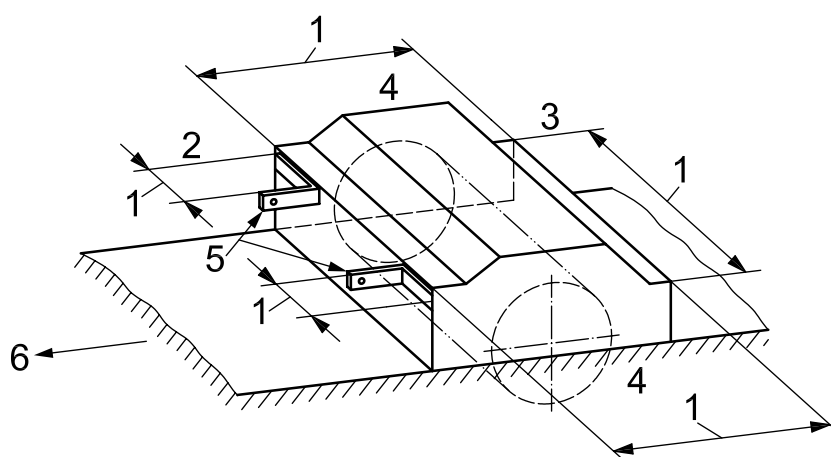

**Key**

- |   |                 |   |  |
|---|-----------------|---|--|
| 1 | accessible zone | 4 | sides                                    |
| 2 | front           | 5 | lower hitch points                       |
| 3 | rear            | 6 | forward direction (rear-mounted machine) |

**Figure 1 — Accessible zones (see 4.3.1)**

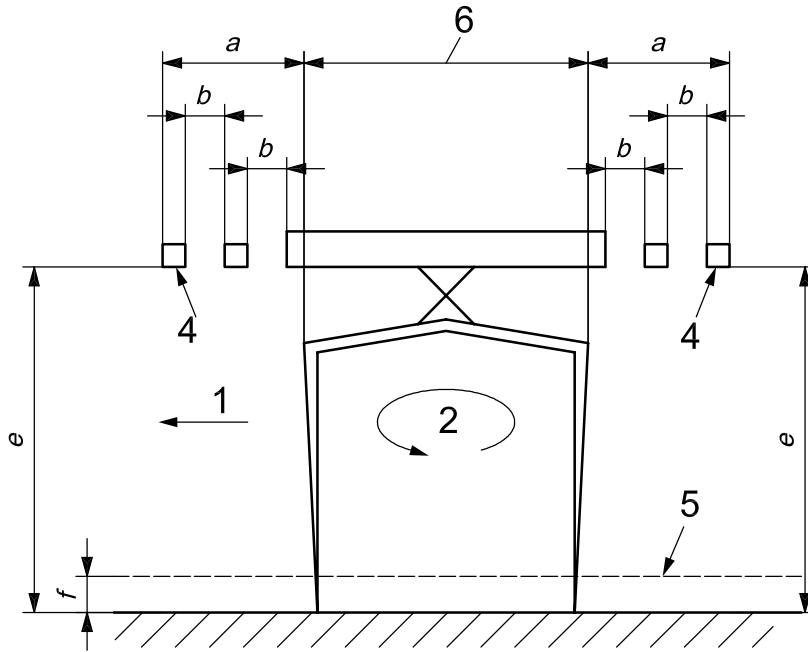

a) Front and rear barriers (see 4.3.1)

**iTeh STANDARD PREVIEW**  
**(standards.iteh.ai)**

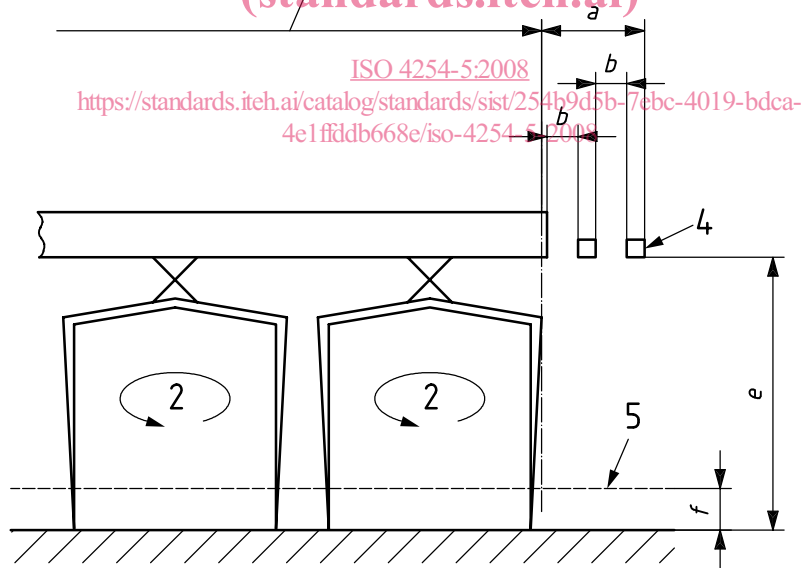

b) Side barriers (see 4.3.1)

ISO 4254-5:2008  
<https://standards.iteh.ai/catalog/standards/sist/254b9d5b-7c9c-4019-bdca-4e1ffddb668e/iso-4254-5:2008>

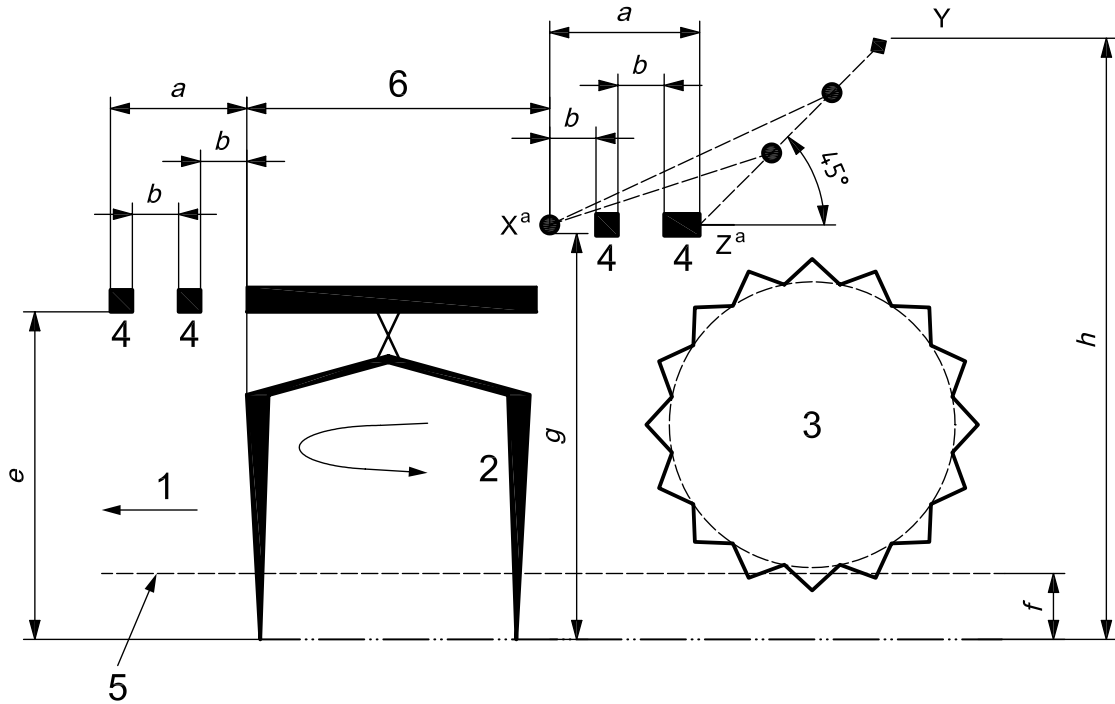

c) Rear guarding (see 4.3.2)

iTeh STANDARD PREVIEW

Dimensions in millimetres

$a$	$b$	$g-f$	$h-f$
$\geq 200$	$\leq 60$ at front $\leq 80$ at rear and sides	$\leq 500$	$\leq 700$
$f$ working depth according to information given by manufacturer in operator's manual			

**Key**

- 1 direction of travel
  - 2 power-driven tool
  - 3 depth control roller
  - 4 barrier
  - 5 ground surface
  - 6 tool path
- a See 4.3.2 b).

Figure 2 — Guarding and barriers — Dimensions