

---

---

**Earth-moving machinery —  
Determination of average ground contact  
pressure for crawler machines**

*Engins de terrassement — Détermination de la pression moyenne de  
contact au sol des engins à chenilles*

**iTeh STANDARD PREVIEW**  
**(standards.iteh.ai)**

[ISO 16754:2008](https://standards.iteh.ai/catalog/standards/sist/5de40162-26a3-42ff-8e95-f6e04eac83d1/iso-16754-2008)

[https://standards.iteh.ai/catalog/standards/sist/5de40162-26a3-42ff-8e95-  
f6e04eac83d1/iso-16754-2008](https://standards.iteh.ai/catalog/standards/sist/5de40162-26a3-42ff-8e95-f6e04eac83d1/iso-16754-2008)



**PDF disclaimer**

This PDF file may contain embedded typefaces. In accordance with Adobe's licensing policy, this file may be printed or viewed but shall not be edited unless the typefaces which are embedded are licensed to and installed on the computer performing the editing. In downloading this file, parties accept therein the responsibility of not infringing Adobe's licensing policy. The ISO Central Secretariat accepts no liability in this area.

Adobe is a trademark of Adobe Systems Incorporated.

Details of the software products used to create this PDF file can be found in the General Info relative to the file; the PDF-creation parameters were optimized for printing. Every care has been taken to ensure that the file is suitable for use by ISO member bodies. In the unlikely event that a problem relating to it is found, please inform the Central Secretariat at the address given below.

**iTeh STANDARD PREVIEW**  
**(standards.iteh.ai)**

ISO 16754:2008

<https://standards.iteh.ai/catalog/standards/sist/5de40162-26a3-42ff-8e95-f6e04eac83d1/iso-16754-2008>



**COPYRIGHT PROTECTED DOCUMENT**

© ISO 2008

All rights reserved. Unless otherwise specified, no part of this publication may be reproduced or utilized in any form or by any means, electronic or mechanical, including photocopying and microfilm, without permission in writing from either ISO at the address below or ISO's member body in the country of the requester.

ISO copyright office  
Case postale 56 • CH-1211 Geneva 20  
Tel. + 41 22 749 01 11  
Fax + 41 22 749 09 47  
E-mail [copyright@iso.org](mailto:copyright@iso.org)  
Web [www.iso.org](http://www.iso.org)

Published in Switzerland

## Foreword

ISO (the International Organization for Standardization) is a worldwide federation of national standards bodies (ISO member bodies). The work of preparing International Standards is normally carried out through ISO technical committees. Each member body interested in a subject for which a technical committee has been established has the right to be represented on that committee. International organizations, governmental and non-governmental, in liaison with ISO, also take part in the work. ISO collaborates closely with the International Electrotechnical Commission (IEC) on all matters of electrotechnical standardization.

International Standards are drafted in accordance with the rules given in the ISO/IEC Directives, Part 2.

The main task of technical committees is to prepare International Standards. Draft International Standards adopted by the technical committees are circulated to the member bodies for voting. Publication as an International Standard requires approval by at least 75 % of the member bodies casting a vote.

Attention is drawn to the possibility that some of the elements of this document may be the subject of patent rights. ISO shall not be held responsible for identifying any or all such patent rights.

ISO 16754 was prepared by Technical Committee ISO/TC 127, *Earth-moving machinery*, Subcommittee SC 1, *Test methods relating to machine performance*.

## iTeh STANDARD PREVIEW (standards.iteh.ai)

[ISO 16754:2008](https://standards.iteh.ai/catalog/standards/sist/5de40162-26a3-42ff-8e95-f6e04eac83d1/iso-16754-2008)

<https://standards.iteh.ai/catalog/standards/sist/5de40162-26a3-42ff-8e95-f6e04eac83d1/iso-16754-2008>

**iTeh STANDARD PREVIEW**  
**(standards.iteh.ai)**

ISO 16754:2008

<https://standards.iteh.ai/catalog/standards/sist/5de40162-26a3-42ff-8e95-f6e04eac83d1/iso-16754-2008>

# Earth-moving machinery — Determination of average ground contact pressure for crawler machines

## 1 Scope

This International Standard specifies a uniform method for calculating the average ground contact pressure of self-propelled and towed crawler (track-laying) earth-moving machines, as defined in ISO 6165, on soft surfaces with empty equipment or attachment.

The average ground contact pressure value is used only for comparing different machine models. Actual ground contact pressure values under operating conditions will vary depending on load, position of the centre of gravity, terrain, track shoe type and size, and surface conditions.

NOTE 1 Alternative methods for determining ground contact pressure could apply to some specific machine families.

NOTE 2 The calculation makes allowance for some penetration into the supporting soil surface and the resulting increase in support area.

## 2 Normative references

The following referenced documents are indispensable for the application of this document. For dated references, only the edition cited applies. For undated references, the latest edition of the referenced document (including any amendments) applies.

ISO 6165:2006, *Earth-moving machinery — Basic types — Identification and terms and definitions*

ISO 6746-1:2003, *Earth-moving machinery — Definitions of dimensions and codes — Part 1: Base machine*

## 3 Terms and definitions

For the purposes of this document, the terms and definitions given in ISO 6746-1 and the following apply.

### 3.1

#### operating mass

#### OM

mass of the base machine, with equipment and empty attachment in the most usual configuration as specified by the manufacturer, and with the operator (75 kg), full fuel tank and all fluid systems (i.e. hydraulic oil, transmission oil, engine oil, engine coolant) at the levels specified by the manufacturer and, when applicable, with sprinkler water tank(s) half-full

NOTE 1 The mass of an operator is not included for non-riding machines.

NOTE 2 Ballast mass included at delivery can be included if specified by the manufacturer.

NOTE 3 The operating mass is expressed in kilograms.

[ISO 6016]

**3.2 overall crawler length**

$L_6$   
distance on X coordinate between two X planes passing through the farthest points on the ground-supported portion of the track undercarriage

See Figure 1.

NOTE 1 It is expressed in millimetres.

NOTE 2  $L_6$  can also be determined according to 4.3.

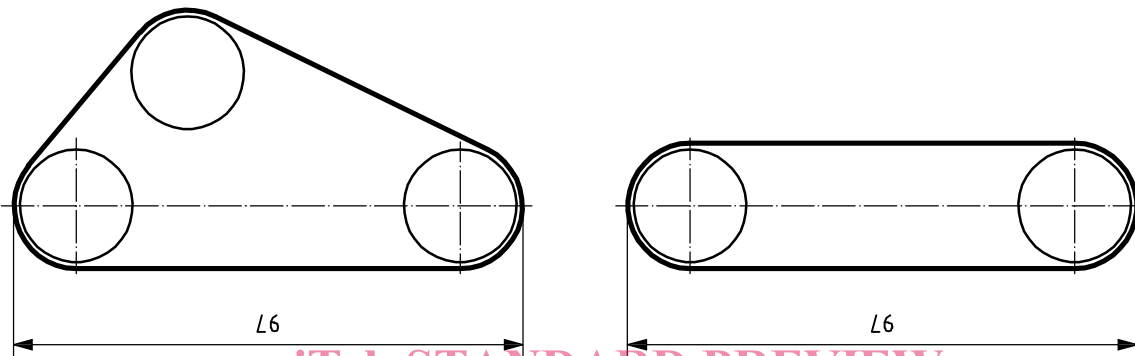

**Figure 1 — Overall crawler length**

**3.3 crawler base**

$L_2$   
distance on X coordinate between two X planes passing through the front idler axis and the sprocket (or rear idler) axis

[ISO 6746-1]

See Figure 2.

NOTE It is expressed in millimetres.

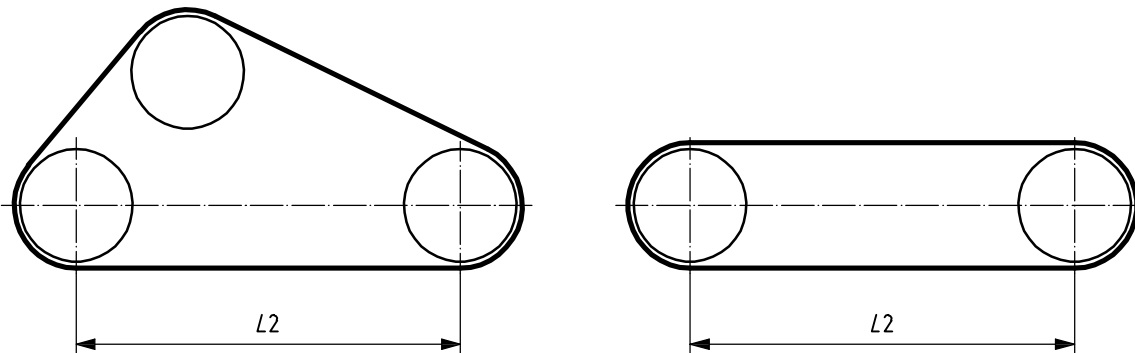

**Figure 2 — Crawler base**

### 3.4 track shoe width

$W_4$

distance on Y coordinate between two Y planes passing through the extreme lateral points of the same track shoe

[ISO 6746-1]

See Figure 3.

NOTE It is expressed in millimetres.

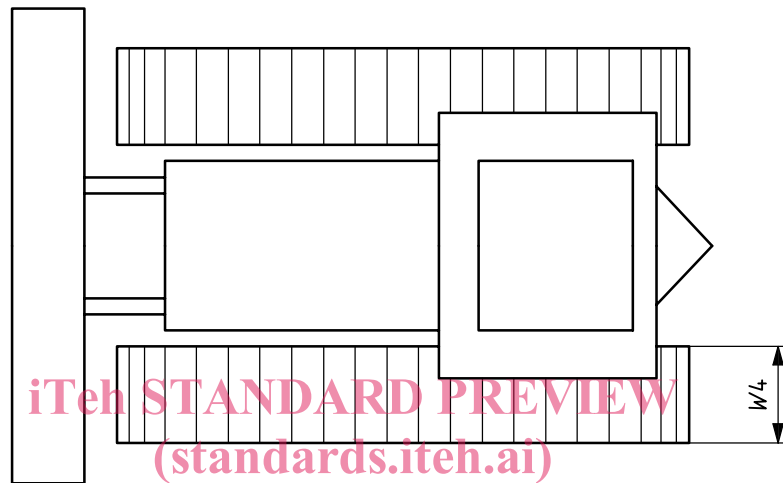

ISO 16754:2008  
<https://standards.iteh.ai/catalog/standards/sist/5dc70102-26a3-42ff-8e95-f6e04eac83d1/iso-16754-2008>  
**Figure 3 — Track shoe width**

## 4 Requirements

### 4.1 General

The machine shall be the standard configuration as specified by the manufacturer.

### 4.2 Calculation of average ground contact pressure, $P_g$

Determine the average ground contact pressure,  $P_g$ , in kilopascals, using Equation (1):

$$P_g = \frac{1\,000 \times 9,807m}{n \times W_4 [L_2 + 0,35(L_6 - L_2)]} \quad (1)$$

where

$m$  is the operating mass;

$n$  is the number of tracks;

$L_2$  is the crawler base;

$L_6$  is the overall crawler length;

$W_4$  is the track shoe width.

NOTE 1 Equation (1) provides allowance for some track penetration into the supporting soil surface and the resulting increase in support area.

NOTE 2 In the Equation (1), symbols with subscripts have been used to represent the dimensions in order to avoid confusion between codes (e.g.  $L_6$ ) and values.

### 4.3 Determination of $L_6$

$L_6$  can also be determined using Equation (2), which can be used for all types of crawler configurations, including that shown in Figure 4, provided that the angle,  $\alpha$ , is greater than or equal to  $10^\circ$ .

$$L_6 = L_2 + 2d \tag{2}$$

where

$d$  is the distance on the Z coordinate between the ground reference plane and the Z plane (see ISO 6746-1) passing through the front and rear roller axis, as shown in Figure 4;

$L_2$  is the crawler base;

$L_6$  is the overall crawler length.

NOTE In the equation, symbols with subscripts have been used to represent the dimensions in order to avoid confusion between (e.g.  $L_6$ ) codes and values.



Angle  $\alpha$  shall be  $\geq 10^\circ$ .

Figure 4 — Distance and angle used in determining  $L_6$



## Bibliography

- [1] ISO 6016, *Earth-moving machinery — Methods of measuring the masses of whole machines, their equipment and components*
- [2] SAE J1309:2003, *Travel Performance and Rating Procedure, Crawler Mounted Hydraulic Excavators, Material Handlers, Knuckle Boom Log Loaders, and Certain Forestry Equipment*

**iTeh STANDARD PREVIEW**  
**(standards.iteh.ai)**

[ISO 16754:2008](https://standards.iteh.ai/catalog/standards/sist/5de40162-26a3-42ff-8e95-f6e04eac83d1/iso-16754-2008)

<https://standards.iteh.ai/catalog/standards/sist/5de40162-26a3-42ff-8e95-f6e04eac83d1/iso-16754-2008>