



Standard Test Method for Basic Calibration of Master Viscometers and Viscosity Oil Standards¹

This standard is issued under the fixed designation D 2162; the number immediately following the designation indicates the year of original adoption or, in the case of revision, the year of last revision. A number in parentheses indicates the year of last reapproval. A superscript epsilon (ϵ) indicates an editorial change since the last revision or reapproval.

This standard has been approved for use by agencies of the Department of Defense.

^{ε1} NOTE—Equation 8 was corrected editorially in November 2001.

1. Scope

1.1 This test method covers the calibration of master viscometers and viscosity oil standards, both of which may be used to calibrate routine viscometers as described in Test Method D 445 and Specifications D 446 over the temperature range from 15 to 100°C.

1.2 The calibration constants in mm^2/s^2 are to be regarded as the standard. The kinematic viscosities in mm^2/s are to be regarded as the standard.

1.3 *This standard does not purport to address all of the safety concerns, if any, associated with its use. It is the responsibility of the user of this standard to establish appropriate safety and health practices and determine the applicability of regulatory limitations prior to use.* For specific precautionary statements see Section 7.

2. Referenced Documents

2.1 ASTM Standards:

- D 445 Test Method for Kinematic Viscosity of Transparent and Opaque Liquids (and the Calculation of Dynamic Viscosity)²
- D 446 Specifications and Operating Instructions for Glass Capillary Kinematic Viscometers²
- D 1193 Specification for Reagent Water³
- D 1250 Guide for Petroleum Measurement Tables²
- D 1480 Test Method for Density and Relative Density (Specific Gravity) of Viscous Materials by Bingham Pycnometer²
- D 1590 Test Methods for Surface Tension of Water and Waste Water³
- E 1 Specification for ASTM Thermometers⁴

¹ This test method is under the jurisdiction of ASTM Committee D-2 on Petroleum Products and Lubricants and is the direct responsibility of Subcommittee D02.07 on Flow Properties.

Current edition approved June 10, 1999. Published August 1999. Originally published as D 2162 – 63 T. Last previous edition D 2162 – 93 (1998).

² Annual Book of ASTM Standards, Vol 05.01.

³ Annual Book of ASTM Standards, Vol 11.01.

⁴ Annual Book of ASTM Standards, Vol 14.03.

2.2 ISO Standard:⁵

ISO 3666 Viscosity of Water

3. Terminology

3.1 Definitions of Terms Specific to This Standard:

3.1.1 *basic calibration, n*—calibration based on the primary standard, water.

3.1.1.1 *Discussion*—Pure water has a kinematic viscosity of 1.0034 mm^2/s (cSt) at 20°C. See ISO 3666.

3.1.2 *master viscometer, n*—glass capillary viscometer with a liquid driving head of at least 400 mm.

3.1.2.1 *Discussion*—It is specially designed to minimize errors due to surface tension, kinetic energy, and capillary end effects.

3.1.3 *viscosity oil standard, n*—stable Newtonian liquid, the kinematic viscosity of which has been related to the kinematic viscosity of water through the step-up procedure described in this test method.

4. Summary of Test Method

4.1 Two or more master viscometers, having calibration constants in the 0.001 to 0.003- mm^2/s^2 (cSt/s) range, are calibrated with water at 20°C. The kinematic viscosities of two or more oil standards are measured at 40°C in these two master viscometers. Corrections are made for buoyancy and, where necessary, for temperature and surface tension.

4.2 A third master viscometer, with a calibration constant of 0.003 to 0.009 mm^2/s^2 (cSt/s), is then calibrated at 40°C with the two standard oils and its calibration factor calculated at standard conditions for water at 20°C. In like manner additional viscosity oil standards and additional master viscometers are calibrated at 40°C using the average results from at least two master viscometers or two oil standards. Steps between successive calibration constants or viscosities increase by a factor of three or less until the desired viscosity range is covered.

⁵ Available from American National Standards Institute, 11 W. 42nd St., 13th floor, New York, NY 10036.

4.3 Oils are calibrated at other temperatures using the average result from at least two master viscometers.

5. Significance and Use

5.1 Because there are surface tension or kinematic viscosity differences, or both, between the primary standard (7.4) and kinematic viscosity standards (7.5), special procedures using master viscometers are required to “step-up” from the kinematic viscosity of the primary standard to the kinematic viscosities of oil standards.

5.2 Using master viscometers calibrated according to this test method, an operator can calibrate kinematic viscometers in accordance with Specifications D 446.

5.3 Using viscosity oil standards established in this test method, an operator can calibrate kinematic viscometers in accordance with Specifications D 446.

6. Apparatus

6.1 *Master Viscometers: Cannon⁶ or Ubbelohde⁷ Type*—Acceptable viscometers are shown in Fig. 1 and Fig. 2. Two masters are required with calibration constants in the 0.001 to 0.003-mm²/s² (cSt/s) range. Additional masters have factors increasing in three-fold steps.

6.2 *Thermometers*—Kinematic viscosity thermometers having a range from 18.5 to 21.5°C, or 38.5 to 41.5°C, and conforming to the requirements for Thermometers 44C and 120C, as prescribed in Specification E 1, and calibrated to

⁶ Cannon, M. R., “Viscosity Measurement, Master Viscometers,” *Industrial and Engineering Chemistry*, Analytical Edition, Vol 16, 1944, p. 708.

⁷ Ubbelohde, L., “The Suspended Lever Viscometer,” *Journal Institute Petroleum Technologists* (London), Vol 22, 1936, p. 37.

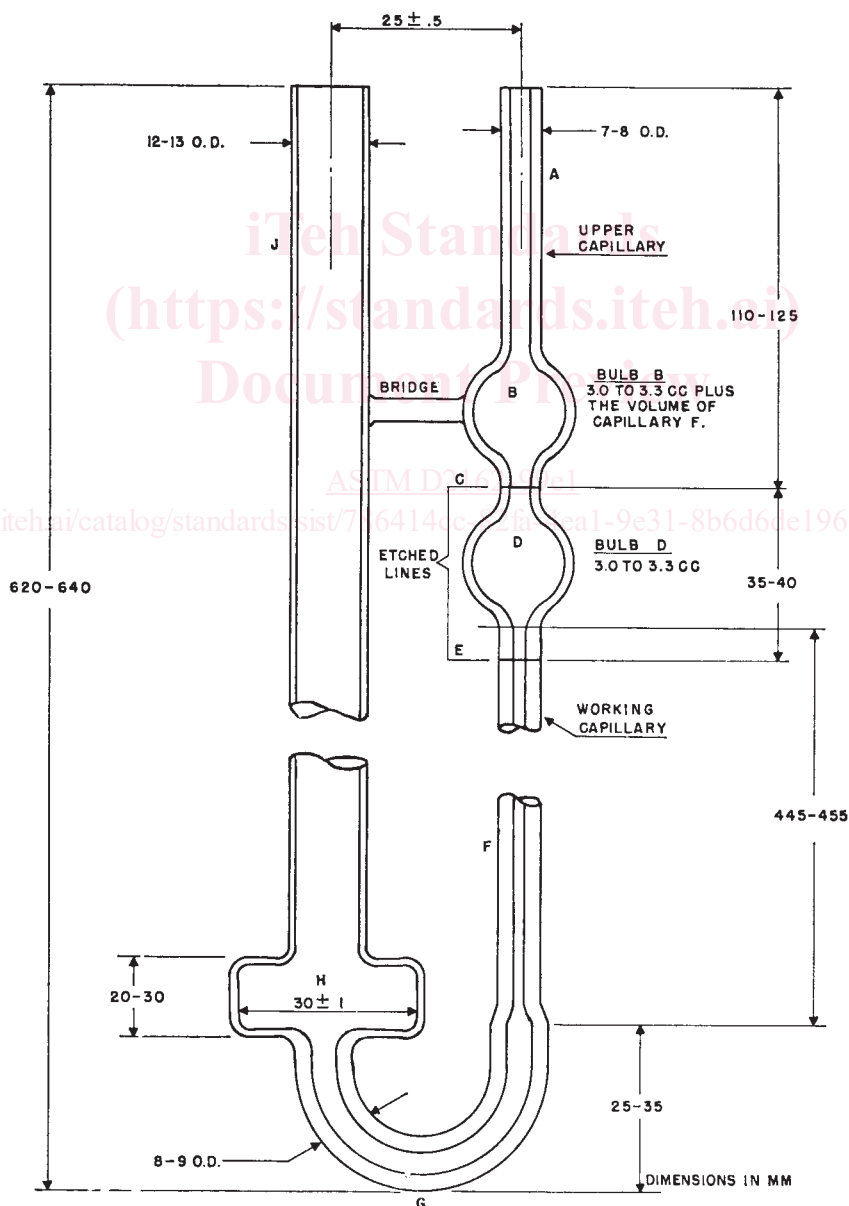

FIG. 1 Cannon Master Viscometer

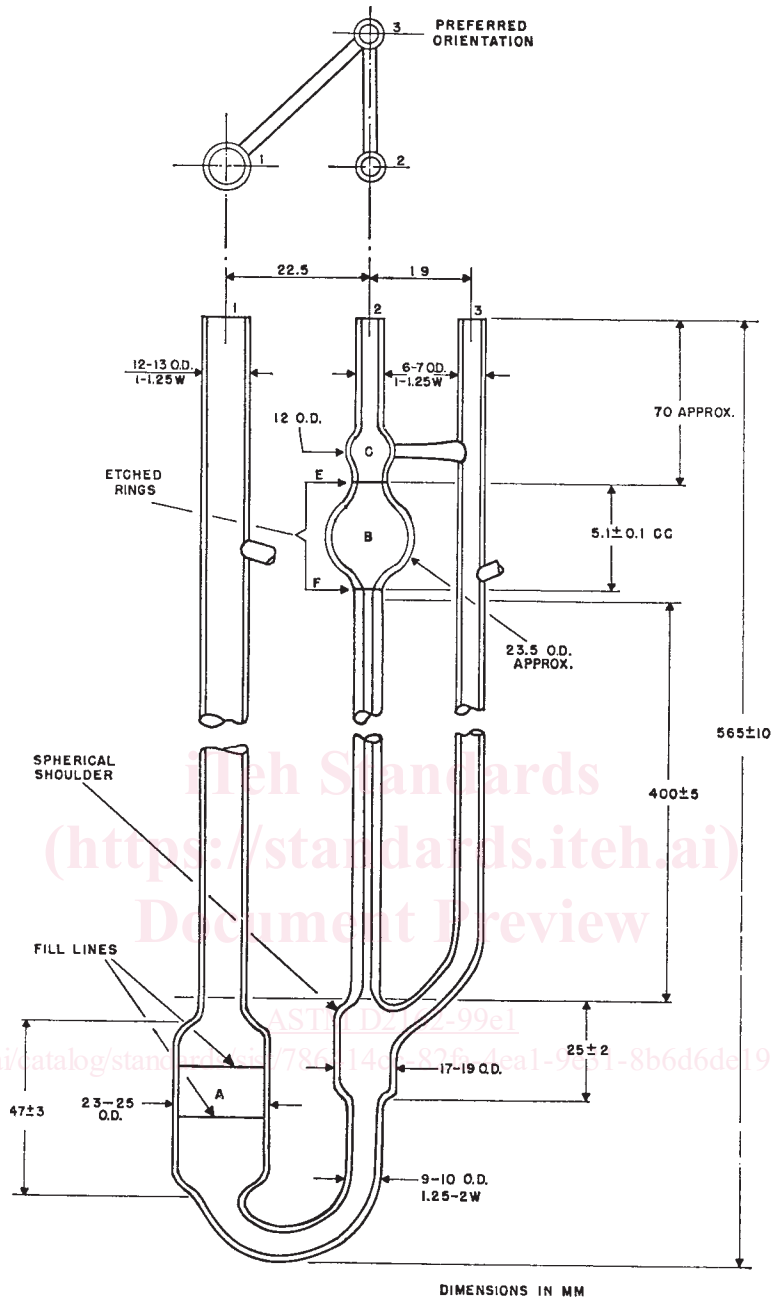

FIG. 2 Ubbelohde Master Viscometer

0.005°C by the National Institute of Standards and Technology or other qualified agency. A standard platinum resistance thermometer together with a Mueller resistance bridge having equivalent or better accuracy is preferable, where available. Other Thermometers 46C, 121C, etc. as required for standardizing oil viscosities at other temperatures may be used.

6.3 *Bath*—A thermostated bath containing water or other transparent liquid deep enough to immerse the master viscometers so that the upper fiducial mark is at least 50 mm below the surface. The efficiency of stirring and the balance between heat loss and input must be such that the temperature of the water does not vary by more than ±0.01°C over the length of the viscometer or from one viscometer position to another. The working section of the bath should be shielded from direct

radiation from heaters and lights. A standard platinum resistance thermometer, approximately 450 mm in length, may be used to ensure that the variation in temperature does not exceed ±0.01°C. Firm supports should be provided to hold the master viscometer in a rigid and reproducible position within 0° 15 min of vertical.

6.4 *Timer*—Either a spring-wound or electric timer capable of measuring time intervals of 300 to 10 000 s with an accuracy of ±0.03 %. The stop watch, fully but not tightly wound, must be used and tested in the same position. For example, if used at 45° inclination, it should have been tested previously in that position. Electric timers must be operated on circuits, the frequencies of which are controlled. Commercial power sources, the frequencies of which are intermittently and not