

---

**Svetloba in razsvetljava - Merjenje in podajanje fotometričnih podatkov svetlobnih virov in svetilk - 1. del: Merjenje in format podatkov**

Light and lighting - Measurement and presentation of photometric data of lamps and luminaires - Part 1: Measurement and file format

Licht und Beleuchtung - Messung und Darstellung photometrischer Daten von Lampen und Leuchten - Teil 1: Messung und Datenformat

Lumière et éclairage - Mesure et présentation des données photométriques des lampes et des luminaires - Partie 1: Mesurage et format de données

[https://standards.iteh.ai/catalog/standards/sist/12865b4a-fe42-44aa-8851-](https://standards.iteh.ai/catalog/standards/sist/12865b4a-fe42-44aa-8851-b484d508b178/sist-en-13032-1-2004a1-2012)

**Ta slovenski standard je istoveten z: EN 13032-1:2004+A1:2012**

---

**ICS:**

17.180.20	Barve in merjenje svetlobe	Colours and measurement of light
91.160.01	Razsvetljava na splošno	Lighting in general

**SIST EN 13032-1:2004+A1:2012**      **en,fr,de**

**iTeh STANDARD PREVIEW**  
**(standards.iteh.ai)**

[SIST EN 13032-1:2004+A1:2012](https://standards.iteh.ai/catalog/standards/sist/12865b4a-fe42-44aa-8851-b484d508b178/sist-en-13032-1-2004a1-2012)

<https://standards.iteh.ai/catalog/standards/sist/12865b4a-fe42-44aa-8851-b484d508b178/sist-en-13032-1-2004a1-2012>

EUROPEAN STANDARD  
NORME EUROPÉENNE  
EUROPÄISCHE NORM

**EN 13032-1:2004+A1**

March 2012

ICS 17.180.20

Supersedes EN 13032-1:2004

English Version

**Light and lighting - Measurement and presentation of  
photometric data of lamps and luminaires - Part 1: Measurement  
and file format**

Lumière et éclairage - Mesure et présentation des données  
photométriques des lampes et des luminaires - Partie 1:  
Mesurage et format de données

Licht und Beleuchtung - Messung und Darstellung  
photometrischer Daten von Lampen und Leuchten - Teil 1:  
Messung und Datenformat

This European Standard was approved by CEN on 16 January 2004 and includes Corrigendum 1 issued by CEN on 26 January 2005 and Amendment 1 approved by CEN on 15 January 2012.

CEN members are bound to comply with the CEN/CENELEC Internal Regulations which stipulate the conditions for giving this European Standard the status of a national standard without any alteration. Up-to-date lists and bibliographical references concerning such national standards may be obtained on application to the CEN-CENELEC Management Centre or to any CEN member.

This European Standard exists in three official versions (English, French, German). A version in any other language made by translation under the responsibility of a CEN member into its own language and notified to the CEN-CENELEC Management Centre has the same status as the official versions.

CEN members are the national standards bodies of Austria, Belgium, Bulgaria, Croatia, Cyprus, Czech Republic, Denmark, Estonia, Finland, France, Germany, Greece, Hungary, Iceland, Ireland, Italy, Latvia, Lithuania, Luxembourg, Malta, Netherlands, Norway, Poland, Portugal, Romania, Slovakia, Slovenia, Spain, Sweden, Switzerland, Turkey and United Kingdom.



EUROPEAN COMMITTEE FOR STANDARDIZATION  
COMITÉ EUROPÉEN DE NORMALISATION  
EUROPÄISCHES KOMITEE FÜR NORMUNG

**Management Centre: Avenue Marnix 17, B-1000 Brussels**

## Contents

	page
Foreword.....	4
Introduction.....	5
1 Scope .....	6
2 Normative references .....	6
3 Terms and definitions .....	6
4 Co-ordinate system .....	7
4.1 General.....	7
4.2 System of measuring planes .....	8
4.2.1 General.....	8
4.2.2 B-planes.....	8
4.2.3 C-planes.....	10
4.2.4 Relationships between the plane systems .....	12
5 Laboratory requirements for tests.....	13
5.1 General.....	13
5.2 Test conditions .....	13
5.2.1 Test room.....	13
5.2.2 Test voltage.....	13
5.2.3 Ambient temperature.....	13
5.2.4 Air movement.....	15
5.2.5 Stabilisation of the light source.....	15
5.3 Electrical power supply.....	15
5.3.1 Current handling capacity .....	15
5.3.2 Stability of supply voltage .....	15
5.3.3 AC frequency .....	15
5.3.4 AC waveform.....	15
5.3.5 DC ripple.....	15
5.3.6 Electro-magnetic field .....	16
5.4 Luminous intensity distribution measurements .....	16
5.5 Luminous flux measurements.....	16
5.6 Luminance measurements .....	16
5.7 Photometric factors .....	17
5.8 Luminaires for test .....	17
6 Requirements for measurement .....	20
6.1 General aspects .....	20
6.1.1 Goniophotometers.....	21
6.1.2 Integrating photometers .....	22
6.1.3 Illuminance meters .....	24
6.1.4 Luminance meters .....	26
6.2 Measurement uncertainties .....	27
7 Basic data format requirements.....	28
8 Electronic transfer of luminaire data.....	28
8.1 General.....	28
8.2 File format.....	28
Annex A (informative) Screening against stray light.....	29
Annex B (normative) Properties of photometers .....	30
B.2.1 Definition .....	30
B.2.2 Measurement.....	31

B.2.3	Characterization.....	31
B.3.1	Definition .....	32
B.3.2	Measurement.....	32
B.3.3	Characterization.....	32
B.4.1	Directional response for the measurement of illuminance .....	33
B.4.2	Directional response for the measurement of luminance .....	35
B.5.1	Description .....	38
B.5.2	Measurement.....	38
B.5.3	Characterization.....	39
B.6.1	Description .....	39
B.6.2	Measurement.....	39
B.6.3	Characterization.....	40
B.7.1	Description .....	40
B.7.2	Measurement.....	40
B.7.3	Characterization.....	40
B.8.1	Definition .....	40
B.8.2	Measurement.....	41
B.8.3	Characterization.....	41
B.10.1	Definition .....	42
B.10.2	Measurement.....	42
B.10.3	Characterization.....	42
B.11.1	Description .....	43
B.11.2	Measurement.....	43
B.11.3	Characterization.....	43
B.12.1	Description .....	44
B.12.2	Lower and upper frequency limits.....	44
B.13.1	Definition .....	45
B.13.2	Measurement.....	45
B.13.3	Characterization.....	45
Annex C (normative)	Testing of mirrors for variation in reflectance and flatness .....	46
Annex D (normative)	CEN File Format .....	47
Annex E (informative)	Examples of the CEN File Format.....	59
Annex F (normative)	<b>A<sub>1</sub></b> Measurement procedure for the photometry of luminaires equipped with T16 lamps or fluorescent compact lamps <b>A<sub>1</sub></b> .....	62
F.2.1	Ageing.....	62
F.2.2	Burn-in (pre-conditioning).....	62
F.2.3	Hot transfer .....	63
F.2.4	Stabilisation .....	63
F.2.5	Multiple use of lamps .....	63
F.2.6	Replacement of measurement lamps .....	63
F.2.7	Storage and transport of lamps .....	63
F.3.1	Electrical wiring .....	64
F.3.2	Measurement procedure .....	64
Bibliography	.....	65

**EN 13032-1:2004+A1:2012 (E)****Foreword**

This document (EN 13032-1:2004+A1:2012) has been prepared by Technical Committee CEN/TC 169 "Light and lighting", the secretariat of which is held by DIN.

This European Standard shall be given the status of a national standard, either by publication of an identical text or by endorsement, at the latest by September 2012, and conflicting national standards shall be withdrawn at the latest by September 2012.

This document includes Amendment 1, approved by CEN on 2012-01-15 and Corrigendum 1<sup>1</sup>, issued by CEN on 2005-01-26.

This document supersedes EN 13032-1:2004.

The start and finish of text introduced or altered by amendment is indicated in the text by tags **A1** **A1**.

The modifications of the related CEN Corrigendum have been implemented at the appropriate places in the text and are indicated by the tags **AC** **AC**.

Acknowledgement is given to CIE for their help in the preparation of this standard.

The European Standard 13032 *Light and lighting - Measurements and presentation of photometric data of lamps and luminaires* is published in the following parts:

*Part 1: Measurement and file format.*

[SIST EN 13032-1:2004+A1:2012](https://standards.iteh.ai/catalog/standards/sist/12865b4a-fe42-44aa-8851-b484d508b178/sist-en-13032-1-2004a1-2012)

*Part 2: Presentation of data for indoor and outdoor work places.*

<https://standards.iteh.ai/catalog/standards/sist/12865b4a-fe42-44aa-8851-b484d508b178/sist-en-13032-1-2004a1-2012>

*Part 3: Emergency lighting (in preparation).*

*Part 4: Sports lighting (in preparation).*

*Part 6: Tunnel lighting (in preparation).*

**A1** *deleted text* **A1**

According to the CEN/CENELEC Internal Regulations, the national standards organizations of the following countries are bound to implement this European Standard: Austria, Belgium, Bulgaria, Croatia, Cyprus, Czech Republic, Denmark, Estonia, Finland, France, Germany, Greece, Hungary, Iceland, Ireland, Italy, Latvia, Lithuania, Luxembourg, Malta, Netherlands, Norway, Poland, Portugal, Romania, Slovakia, Slovenia, Spain, Sweden, Switzerland, Turkey and United Kingdom.

<sup>1</sup> This corrigendum was relating to the extension of the DOW of EN 13032-1:2004.

## Introduction

The provision of reliable and accurate photometric data is a basic requirement for any lighting engineer in order to design a good lighting scheme.

This European Standard aims to put on a common basis current European lighting practices so that a luminaire with its associated performance data, purchased in one country, can be directly compared and accurately employed in another country.

The standard is a guide to procedures referring where necessary to the relevant CIE, ISO and CEN publications.

The reliability of these data depends also on well defined qualifications about the management, the organisation and the metrological referability of the Laboratory and the skill of the staff.

**A1** Due to the specific handling requirements for T16 and compact fluorescent lamps, these lamps are covered separately (normative Annex F). **A1**

## iTeh STANDARD PREVIEW (standards.iteh.ai)

[SIST EN 13032-1:2004+A1:2012](https://standards.iteh.ai/catalog/standards/sist/12865b4a-fe42-44aa-8851-b484d508b178/sist-en-13032-1-2004a1-2012)

<https://standards.iteh.ai/catalog/standards/sist/12865b4a-fe42-44aa-8851-b484d508b178/sist-en-13032-1-2004a1-2012>

**EN 13032-1:2004+A1:2012 (E)****1 Scope**

This European Standard establishes general principles for the measurement of basic photometric data for lighting application purposes.

It establishes the measurement criteria needed for the standardisation of basic photometric data and details of the CEN file format for electronic data transfer.

This is part 1 of a multi part standard. Part 1 deals with the basic photometric measurement and file format. Other parts deal with lamps and luminaires data depending on the applications.

**2 Normative references**

This European Standard incorporates by dated or undated reference, provisions from other publications. These normative references are cited at the appropriate places in the text, and the publications are listed hereafter. For dated references, subsequent amendments to or revisions of any of these publications apply to this European Standard only when incorporated in it by amendment or revision. For undated references the latest edition of the publication referred to applies (including amendments).

EN 12665:2002, *Light and lighting — Basic terms and criteria for specifying lighting requirements*

EN 60081, *Doublecapped fluorescent lamps — Performance specifications (IEC 60081)*

EN 60901, *Single-capped fluorescent lamps — Performance specifications (IEC 60901)*

ISO 9660, *Information processing — Volume and file structure of CD-ROM for information interchange*

*SIST EN 13032-1:2004+A1:2012*  
<https://standards.iteh.ai/catalog/standards/sist/12865b4a-fc42-44aa-8851-b484d508b178/sist-en-13032-1-2004a1-2012>

**3 Terms and definitions**

For the purposes of this European Standard, the terms and definitions given in EN 12665 together with the following apply.

**3.1****light source**

lamp or luminaire

**3.2****photometric centre**

point in a luminaire or lamp from which the photometric distance law operates most closely in the direction of maximum intensity

NOTE It is the origin of the coordinate system used for the measuring of luminous intensity distribution and should be specified.

**3.3****limiting photometric distance**

minimum distance for deriving the luminous intensity from the measured illuminance

**3.4****relative measurement**

measurement obtained as a ratio of two quantities of the same type expressed in arbitrary units. Photometric measurement in SI units relative to specified bare lamp flux

[CIE 121:1996, definition 2.3.2]



**3.5****luminaire data per 1 000 lm (of lamp flux)**

photometric data of luminaire relative to a total theoretical luminous flux of 1 000 lm from all the lamps of the luminaire, when these are operated outside the luminaire under reference conditions but with the same ballast(s)

**3.6****luminous intensity distribution (of a luminaire)**

distribution of luminous intensity with direction. The luminous intensity distribution may be represented by numerical tables or by graphics and is usually expressed in units of candelas per 1 000 lm of lamp flux

**A1 3.7****measurement lamp**

lamp used for the photometric characterisation of a luminaire

**3.8****cold spot (of a fluorescent lamp)**

coldest point on the discharge tube that determine the Hg-pressure in the discharge tube 

**4 Co-ordinate system****4.1 General<sup>2</sup>**

The determination of the intensity distribution involves the use of a co-ordinate system in order to define the direction in which the intensity measurements are made; the system used is a spherical co-ordinate system with the centre coincident with the photometric centre of the luminaire.

From a general point of view the co-ordinate system consists in a group of planes with a single axis of intersection: the polar axis. In this system a direction in space is characterised by two angles:

- a)- the angle between the plane taken as a conventional origin and the half plane containing the considered direction;
- b) - the angle between the polar axis and the considered direction or the complement of this angle.

The orientation of this system with respect to the first axis and the second axis (see Figure 1) of the luminaire is chosen with particular regard to the type of luminaire, to the type of lamp, to the mounting attitude of the luminaire and its application, in order to perform more accurate measurements or to simplify the consequent lighting calculations.

The identification of the first axis and the second axis shall be defined by the manufacturer or the photometric laboratory according to this standard. The third axis is the axis containing the photometric centre and perpendicular to the two first axes. For information on the location of the photometric centre see clause 5.8.

**NOTE** Usually the first axis of a luminaire is perpendicular to the light emitting area of the luminaire. As the light emitting area is not always clearly defined and could be curved, the relationship between this axis and a mechanical feature of the luminaire should be declared (e.g., the design attitude for road luminaires or the front glass for floodlights and for ceiling mounted luminaires the surface upon which the luminaire is mounted).

<sup>2</sup> See CIE 121, 3.3.

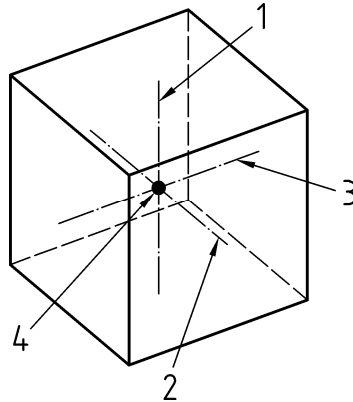
**Key**

- 1 First axis
- 2 Second axis
- 3 Third axis
- 4 Photometric centre

**Figure 1 — Photometric centre and photometric axes of the luminaire**

## 4.2 System of measuring planes

### 4.2.1 General

In general the luminous intensity distribution of a luminaire is measured in a number of planes. From the variety of possible measuring planes three systems of planes have been historically used and were identified by the CIE as A-, B- and C-planes. The same terminology is adopted in this standard, but A-planes system is disregarded.

The C-planes system is to be considered as the recommended standard system.

The B-planes system may also be used, in particular for the photometry of luminaires such as floodlights.

Any two of these planes with an angular difference of  $180^\circ$  will form a plane in the mathematical sense.

### 4.2.2 B-planes<sup>3</sup>

The totality of B-planes (see Figure 2) is the group of planes for which the line of intersection (polar axis) goes through the photometric centre and is parallel to the second axis of the luminaire.

B-planes are marked with angles  $B_x$  with  $-180^\circ \leq B_x \leq +180^\circ$ . Within a plane directions are given by the angle  $\beta$  with  $-90^\circ \leq \beta \leq +90^\circ$ . The system of B-planes is coupled rigidly to the light source and follows its tilt if the luminaire is tilted.

The photometric centre of the luminaire lies in the centre of the co-ordinate system.

The first axis of the luminaire lies in plane  $B_0$ , is perpendicular to the polar axis through the photometric centre and points in the direction  $\beta = 0^\circ$ .

The second axis of the luminaire is coincident with the polar axis.

<sup>3</sup> See CIE 121, 3.4.2.

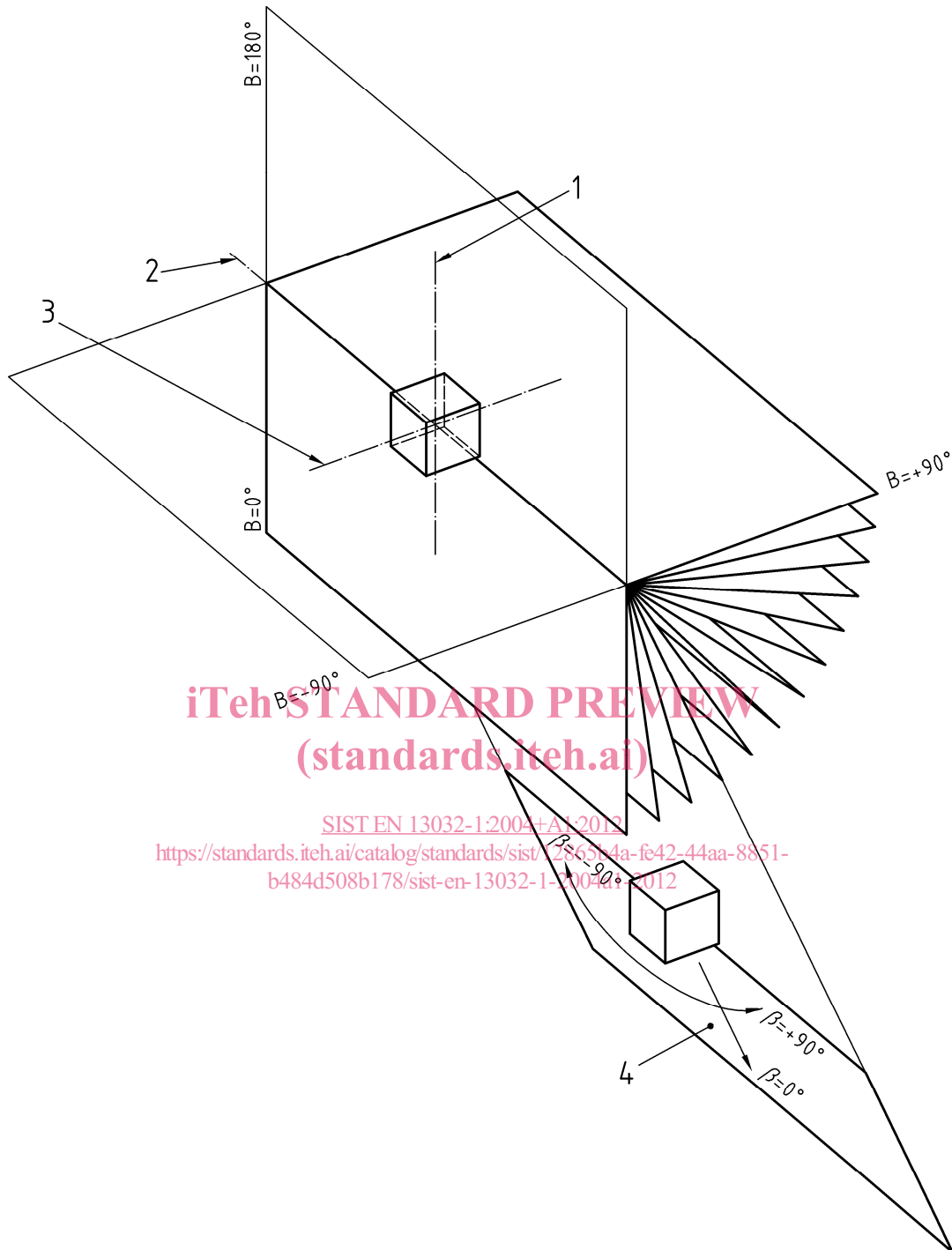

iTeh STANDARD PREVIEW  
(standards.iteh.ai)

SIST EN 13032-1:2004+A1:2012

<https://standards.iteh.ai/catalog/standards/sist/2865b4a-fe42-44aa-8851-b484d508b178/sist-en-13032-1-2004-a1-2012>

#### Key

- 1 First axis
- 2 Second axis, polar axis
- 3 Third axis
- 4 Page = B-Plane

**Figure 2 — Luminaire orientation for B-planes**

Conventions related to the choice of axes linked to the luminaire:

- 1) The first axis of the luminaire is the axis through the photometric centre and perpendicular to the plane which is representative for the main light emitting area.

## EN 13032-1:2004+A1:2012 (E)

- 2) For floodlights the second axis of the luminaire generally is parallel to the spigot or tilting axis of the luminaires. If orientation of the lamp requires a different orientation of the second axis, it shall be stated by the lamp manufacturer or the photometric laboratory.
- 3) For luminaires other than floodlights containing linear single or double ended lamps, the axis of the lamp or the geometric axis of multiple lamps, is chosen as the third axis of the luminaire, perpendicular to the two first ones. Thus the transverse plane to the lamps of the luminaire, which is generally the most extensive light emitting plane, lies in the  $B_0$  plane (for luminaires with a symmetry in this transverse plane in  $B_0 / B_{180}$  plane).
- 4) For other luminaires with the lamp axis coincident with the first axis of the luminaire, for other luminaires with multiple lamps or for other luminaires where no lamp axes can be defined, the luminaire shall be orientated that:
  - a) the maximum intensity  $I_{\max}$  of the light distribution is within the  $B_0$  plane or if  $I_{\max}$  is located at  $\beta = 0^\circ$  or if there are more than one location of  $I_{\max}$ ;
  - b) the  $B_0 / B_{180}$  plane is the symmetry plane of the luminous intensity distribution with the highest degree of symmetry.

If the convention 1) or 2) is applicable or if different conventions are used, the choice of luminaires axes shall be stated by the manufacturer or the photometric laboratory, so as to clearly identify the luminaire alignment in the co-ordinate system, both for photometric measurements and for lighting calculations.

4.2.3 C-planes<sup>4</sup>

## iTeh STANDARD PREVIEW

(standards.iteh.ai)

The totality of C-planes (see Figure 3) is the group of planes for which the line of intersection (polar axis) is the vertical line through the photometric centre. The polar axis does not necessarily coincide with the first axis of the luminaire, if the luminaire is tilted during measurements.

<https://standards.iteh.ai/catalog/standards/sist/12865b4a-fe42-44aa-8851-6484c5085178/sist-en-13032-1-2004-a1-2012>

C-planes are marked with angles  $C_x$  with  $0^\circ \leq C_x < 360^\circ$ . Within a plane directions are given by the angle  $\gamma$  with  $0^\circ \leq \gamma \leq 180^\circ$ . The direction  $\gamma = 0^\circ$  is oriented to the nadir.

<sup>4</sup> See CIE 121, 3.4.3.

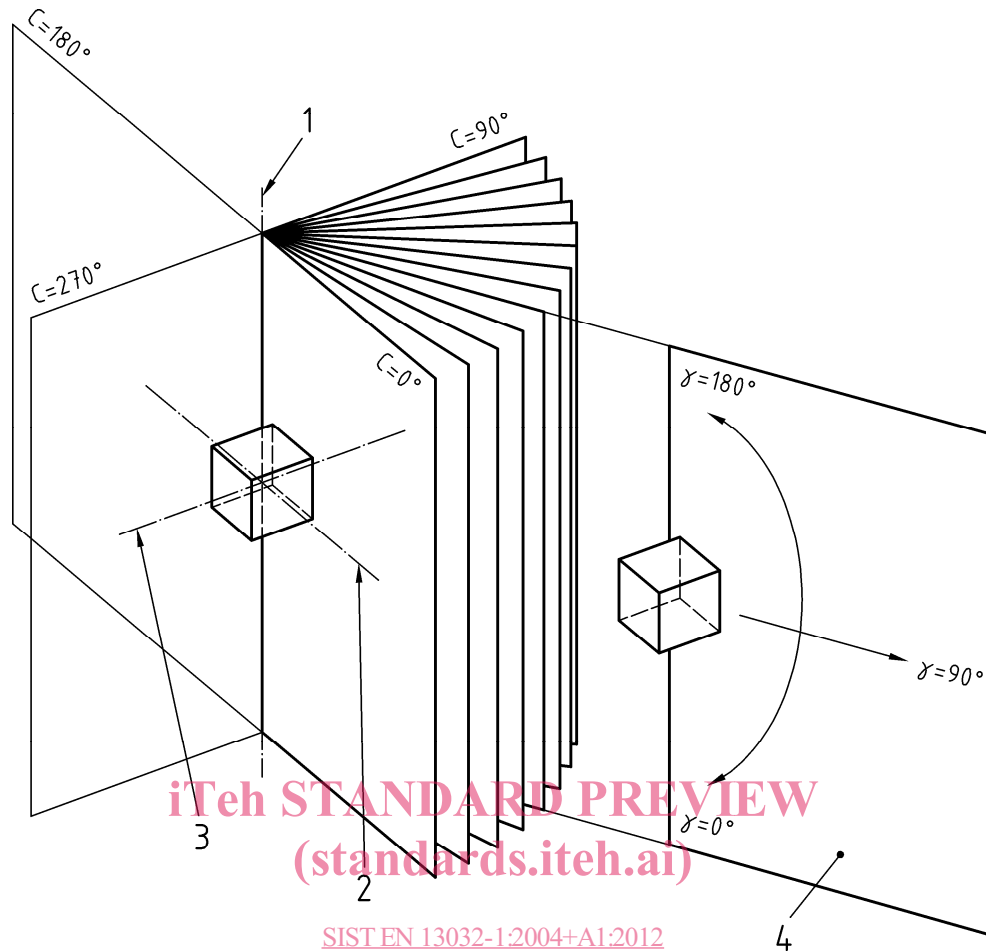

SIST EN 13032-1:2004+A1:2012  
<https://standards.iteh.ai/catalog/standards/sist/12865b4a-fe42-44aa-8851-b484d508b178/sist-en-13032-1-2004a1-2012>

**Key**

- 1 First axis, polar axis
- 2 Second axis
- 3 Third axis
- 4 Page = C-plane

**Figure 3 — Luminaire orientation for C-planes**

The system of C-planes is oriented rigidly in space and does not follow a tilt of the luminaire.

If the luminaire is tilted during measurement (the polar axis is not coincident with the first axis of the luminaire), the angle of tilt should be declared (see Figure 4).

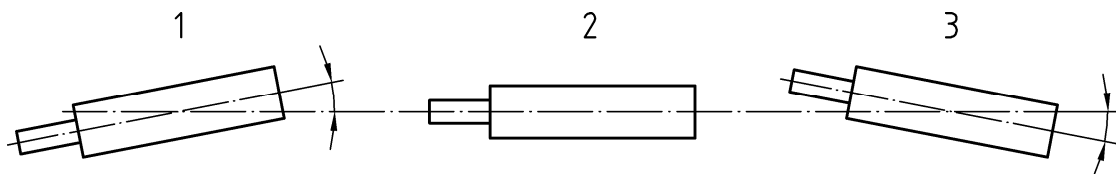
**Key**

- 1 Positive tilt angle
- 2 Zero tilt angle
- 3 negative tilt angle

**Figure 4 — Definition of tilt angle**

## EN 13032-1:2004+A1:2012 (E)

Conventions related to the choice of axes linked to the luminaire:

- 1) The first axis of the luminaire is the axis through the photometric centre and perpendicular to the plane which is representative of the main light emitting area.
- 2) For luminaires containing linear single or double ended lamps, the axis of the lamp or the geometric axis of multiple lamps, is chosen as the third axis of the luminaire, perpendicular to the two first ones. It means that the transverse plane to the lamps of the luminaire, which is generally the most extensive light emitting plane, lies in the  $C=0$  plane (for luminaires with a symmetry in this transverse plane in  $C_0/C_{180}$  plane).
- 3) For luminaires with the lamp axis coincident with the first axis of the luminaire, for luminaires with multiple lamps or for luminaires where no lamp axes can be defined, the luminaire shall be orientated that:
  - a) the maximum intensity  $I_{\max}$  of the light distribution is within the  $C_0$  plane or if  $I_{\max}$  is located at  $\gamma = 0^\circ$  or if there are more than one location of  $I_{\max}$ ;
  - b) the  $C_0/C_{180}$  plane is the symmetry plane of the luminous intensity distribution with the highest degree of symmetry.

If the latest convention 1) or 2) is applicable or if different conventions are used, the choice of luminaires axes shall be stated by the manufacturer or the photometric laboratory, as to clearly identify the luminaire alignment in the co-ordinate system, as well for photometric measurements as for lighting calculations.

NOTE For road lighting calculations, the usual convention is that the  $C_0/C_{180}$  intensity planes lie parallel to the road. This is normally the case for most transversely mounted luminaires, but not for luminaires with linear lamp(s) where the lamp axis is parallel to the road axis.

SIST EN 13032-1:2004+A1:2012

#### 4.2.4 Relationships between the plane systems<sup>5</sup>

The value of the light intensity measured in a certain direction is independent of the way the direction is presented. Generally the values of each of the two angles are different for any direction in the aforementioned plane systems. The angular values of one plane system can be converted into the corresponding angular values of another plane system if the relationships given in the following Table 1 are used. The relationships are only valid if the tilt angle of the luminaire in the C-plane system is zero and as far as the second axis of the luminaire respects the conventions for luminaire orientations in the two co-ordinate systems.

**Table 1 — Conversion equations for plane systems**

Orientation Planes		For Conversion of Angles	
Given	Wanted	For Planes	For Angles
$B, \beta$ $C, \gamma$	$C, \gamma$ $B, \beta$	$\tan C = \sin B / \tan \beta$ $\tan B = \sin C \times \tan \gamma$	$\cos \gamma = \cos B \times \cos \beta$ $\sin \beta = \sin C \times \sin \gamma$

NOTE In some countries, the defined B-planes system has also been named A-planes system. To avoid confusion with the co-ordinate systems originally defined by CIE, A-plane name for this system is not recommended.

<sup>5</sup> See CIE 121, 3.4.4.

## 5 Laboratory requirements for tests

### 5.1 General<sup>6</sup>

The object of the tests is to measure the characteristics of the luminaire by means of appropriate equipment and procedures under the following test conditions which are comparable between laboratories and which relate as closely as practicable to the typical conditions of service for which the luminaire is designed.

### 5.2 Test conditions

#### 5.2.1 Test room

Measuring location: A luminaire shall be measured in surroundings so arranged that the photometer head receives only light from the luminaire direct or with intended reflection. Stray light shall be minimised according to the requirements in annex A.

#### 5.2.2 Test voltage<sup>7</sup>

The test voltage at the supply terminals shall be the rated lamp voltage or the rated circuit voltage appropriate to the lamp control gear in use, if any.

The voltage shall be controlled in accordance with Table 2.

#### 5.2.3 Ambient temperature<sup>8</sup>

The mean ambient temperature,  $T_m$ , shall equal  $(25 \pm 1)$  °C throughout the test of the light source, except where larger tolerances are indicated in table 2.

If the temperature for which the nominal luminous flux of a fluorescent lamp is published is other than 25 °C, a correction factor, supplied by the lamp manufacturer, shall be applied by the laboratory.

The ambient temperature shall be measured at a horizontal distance not exceeding 1,5 m to the surface of the light source with the lamps switched on.

Photometric measurements not made in accordance with the mean ambient test temperature shall have correction factors applied to the individual readings.

---

<sup>6</sup> See CIE 121, 4.1 and 4.3.

<sup>7</sup> See CIE 121, 4.2.5.

<sup>8</sup> See CIE 121, 4.3.1.