



Designation: D 1998 – 04

Standard Specification for Polyethylene Upright Storage Tanks¹

This standard is issued under the fixed designation D 1998; the number immediately following the designation indicates the year of original adoption or, in the case of revision, the year of last revision. A number in parentheses indicates the year of last approval. A superscript epsilon (ϵ) indicates an editorial change since the last revision or reapproval.

1. Scope*

1.1 This specification covers flat-bottom, upright, cylindrical tanks molded in one-piece seamless construction by rotational molding. The tanks are molded from polyethylene for above ground, vertical installation and are capable of containing aggressive chemicals at atmospheric pressure. Included are requirements for materials, properties, design, construction, dimensions, tolerances, workmanship and appearance. Tank capacities are from 1900 L [500 gal] up.

1.2 This specification does not cover the design of vessels intended for use at pressures other than atmospheric pressure. Furthermore, this specification does not cover the design of portable tanks. It is also not for vessels intended for use with liquids heated above their flash points, or temperatures above 66°C [150°F] for Type I tanks and 60°C [140°F] for Type II tanks for continuous service. *NFPA Standards 30 and 31 shall be consulted for installations that are subject to the requirements of these standards.*

1.3 Special design considerations not covered in this specification shall be given to vessels subject to superimposed mechanical forces, such as seismic forces, wind load or agitation; to vessels subject to service temperature in excess of 23°C [73.4°F]; and vessels subject to superimposed pressure exceeding 25.4 cm [10 in.] of water or 2.5×10^{-3} MPa [0.36 psi].

1.4 The values stated in SI units are to be regarded as the standard. The values given in brackets are for information only.

NOTE 1—There is no similar or equivalent ISO standard.

1.5 The following precautionary caveat pertains only to the test methods portion, Section 11, of this specification: *This standard does not purport to address all of the safety concerns,*

¹ This specification is under the jurisdiction of ASTM Committee D20 on Plastics and is the direct responsibility of Subcommittee D20.15 on Thermoplastic Materials (Section D20.15.01).

Current edition approved November 1, 2004. Published December 2004. Originally approved in 1991. Last previous edition approved in 1997 as D 1998 - 97.

if any, associated with its use. It is the responsibility of the user of this standard to establish appropriate safety and health practices and determine the applicability of regulatory limitations prior to use.

2. Referenced Documents

2.1 ASTM Standards:²

D 618 Practice for Conditioning Plastics for Testing

D 883 Terminology Relating to Plastics

D 1693 Test Method for Environmental Stress-Cracking of Ethylene Plastics

D 2837 Test Method for Obtaining Hydrostatic Design Basis for Thermoplastic Pipe Materials or Pressure Design for Thermoplastic Pipe Products

D 3892 Practice for Packaging/Packing of Plastics

D 4703 Practice for Compression Molding Thermoplastic Materials into Test Specimens, Plaques, or Sheets

E 691 Practice for Conducting an Interlaboratory Study to Determine the Precision of a Test Method

F 412 Terminology Relating to Plastic Piping Systems

2.2 OSHA Standard:

29 CFR 1910.106 Occupational Safety and Health Administration, Flammable and Combustible Liquids³

2.3 ANSI Standard: 6d652180492/astm-d1998-04

B-16.5 Pipe Flanges and Flanged Fittings⁴

2.4 NFPA Standards:

30 Flammable and Combustible Liquid Code⁵

31 Installation of Oil Burning Equipment⁵

² For referenced ASTM standards, visit the ASTM website, www.astm.org, or contact ASTM Customer Service at service@astm.org. For *Annual Book of ASTM Standards* volume information, refer to the standard's Document Summary page on the ASTM website.

³ Available from Occupational Safety and Health Administration (OSHA), 200 Constitution Ave., NW, Washington, DC 20210.

⁴ Available from American National Standards Institute (ANSI), 25 W. 43rd St., 4th Floor, New York, NY 10036.

⁵ Available from National Fire Protection Association (NFPA), 1 Batterymarch Park, Quincy, MA 02269-9101.

*A Summary of Changes section appears at the end of this standard.

3. Terminology

3.1 *Definitions:* Definitions are in accordance with Terminologies **D 883** and **F 412** and the Association of Rotational Molders (ARM) Glossary of Terms,⁶ unless otherwise indicated.

3.2 *Definitions of Terms Specific to This Standard:*

3.2.1 *impact failure, n*—any crack in the test specimen resulting from the impact and visible in normal room lighting to a person with normal eyesight.

3.2.2 *rotational molding, n*—a three-stage commercial process consisting of loading the mold with powdered resin, fusing the resin by heating while rotating the mold about more than one axis, and cooling and removing the molded article.

3.2.3 *service factor, n*—a number less than 1.0 (that takes into consideration all the variables and degrees of safety involved in a polyethylene storage tank installation) that is multiplied by the hydrostatic design basis to give the design hoop stress.

4. Classification

4.1 Tanks meeting this specification are classified according to type as follows, and it is the responsibility of the purchaser to specify Type I or Type II:

4.1.1 Type I—Tanks molded from cross-linkable polyethylene.

4.1.2 Type II—Tanks molded from non-cross-linkable polyethylene.

5. Materials

5.1 This specification is based upon the use of 100 % virgin polyethylene intended for the rotational molding process. Any use of regrind, recycled or reprocessed materials, or combinations of such materials, shall not rely upon the performance data of their original constituents, but must meet the requirements of this specification in its own right.

5.1.1 The polyethylene shall have a stress-cracking resistance of 500 h minimum F50 in accordance with Test Method **D 1693**, Condition A, full-strength stress-cracking agent. The test specimens shall be compression molded or rotational molded. If compression molded, Procedure C of Annex A1 of Practice **D 4703** shall be followed for both types of polyethylene with a minimum platen temperature of 177°C [350°F] for Type II materials. The temperature for Type I (cross-linkable) polyethylene shall be 197°C [390°F] and the platen shall be kept closed under full pressure for five minutes at the specified temperature in order to bring about the crosslinking reaction. If the test specimens are rotational molded, the conditions for rotational molding shall be similar to the conditions used for molding a tank from this polyethylene.

NOTE 2—The stress-cracking test is not used as an indicator of general chemical resistance of a polyethylene. Refer to the polyethylene supplier's or molder's chemical-resistance chart for information on the resistance of the polyethylene to specific chemicals or products, or test specific products or chemicals prior to use.

5.2 All tanks used for outdoor installation shall contain an ultraviolet stabilizer at a level adequate to give protection for the intended service life of the tanks. This stabilizer shall be compounded into the polyethylene.

5.3 Any pigments added must be compatible with the polyethylene and shall not exceed 0.5 % dry blended, and 2 % compounded in, of the total weight.

NOTE 3—The use of dry-blended pigments may have an effect on physical properties, that is, impact strength.

5.4 Each resin used in designing tanks covered by this specification shall have hydrostatic-hoop-stress data available.

6. Design Requirements for Both Type I and Type II Tanks

Design Requirements for Both Type I and Type II Tanks

6.1 *Cylinder Shell (Unsupported Portion of Tanks)*—The minimum required wall thickness of the cylindrical shell at any fluid level shall be determined by the following equation, but shall not be less than 4.7 mm [0.187 in.] thick. The tolerance indicated in **9.1.2** applies to these dimensions.

$$T = P \times OD/2 \text{ SD} \quad (1)$$

where:

T = wall thickness, mm [in.],

P = pressure, MPa (0.0098 MPa/m-H₂O × $SG \times H$ (m)),
or psi (0.433 psi/ft-H₂O × $SG \times H$ (ft)),

SG = specific gravity of fluid,

H = fluid head, m [ft],

OD = outside diameter of tank, mm [in.], and

SD = hydrostatic design stress, MPa [psi].

6.1.1 The hydrostatic design stress that is used to determine the minimum wall thickness at any fluid level must be based on hoop stress data for the resin. The hoop stress data, obtained in accordance with the procedures of Test Method **D 2837**, provide a hydrostatic-design-basis for the resin. The hydrostatic-design-basis must be reduced by a service factor to determine the actual hydrostatic design stress. The maximum service factor shall be 0.5 for wall thicknesses less than 9.5 mm [0.375 in.]. For thicknesses equal to or greater than 9.5 mm [0.375 in.], the maximum service factor shall be 0.475. For example, if the hydrostatic-design-basis for the resin is 8.7 MPa [1260 psi], the hydrostatic design stress for a tank with wall thickness greater than 9.5 mm [0.375 in.] is $0.475 \times 8.7 = 4.1$ MPa [or $0.475 \times 1260 = 600$ psi].

6.1.2 Tank hoop stresses shall be derated for service above 23°C [73.4°F].

6.2 *Cylinder Shell (Externally Supported Tanks)*—The minimum required wall thickness for the cylinder straight shell must be sufficient to support its own weight in an upright position without any external support, but shall not be less than 4.7 mm [0.187 in.] thick. The tolerance indicated in **9.1.2** applies to these dimensions.

6.3 *Top Head*—Must be integrally molded with the cylinder shell. The minimum thickness of the top head shall be equal to the top of the straight wall.

6.4 *Bottom Head*—Must be integrally molded with the cylinder shell. The minimum thickness for a full-supported flat-bottom head shall be 4.7 mm [0.187 in.]. The radius of the bottom knuckle of a flat-bottom tank shall not be less than 25.4 mm [1 in.] for tanks with a diameter less than 1.8 m [6 ft] and

⁶ Available from Association of Rotational Molders, 2000 Spring Road, Suite 511, Oak Brook, IL 60523.

38.1 mm [1.5 in.] for a diameter greater than 1.8 m [6 ft]. The minimum thickness of the radius shall not be less than the maximum thickness of the cylinder wall.

6.5 *Open-Top Tanks*—The top edge of open tanks shall be reinforced by design to maintain its shape after installation.

7. Fittings

7.1 Fabricated nozzles, gaskets, and other fitting accessories must be chemically compatible with the materials to be handled in the tanks.

7.2 Openings that are cut in tanks to install fittings must not have sharp corners. Holes shall have minimum clearance to insure best performance of fittings.

7.3 The size, location, and specification, and so forth, for manways and fittings shall be agreed upon between the purchaser and the manufacturer.

7.4 The vents must comply with OSHA 1910.106 (F) (iii) (2) (IV) (9) normal venting for atmospheric tanks, or other accepted standard, or shall be at least as large as the filling or withdrawal connection, whichever is larger but in no case less than 25.4 mm [1 in.] nominal inside diameter.

7.5 Fittings installed in tanks shall be of appropriate strength to meet manufacturer and purchaser specifications.

7.6 Bolts securing mechanical fittings must be manufactured of materials compatible with tank contents.

7.7 Provisions shall be made to attach hold-down devices to the tanks for outdoor service.

7.8 For all flanged connectors, the flange drilling and bolting shall be in accordance with ANSI/ASME B-16.5 for 150 psi [1 MPa] pressure class straddling the principal centerline of the vessel.

8. Performance Requirements

8.1 The following performance requirements shall be met by Type I and Type II tanks:

8.1.1 *Low-Temperature Impact*—Low-temperature impact shall be determined using the test method described in 11.3. The requirements for Type I and Type II tanks are as follows:

Wall thickness, mm [in.]	Impact energy, min. J [ft-lb]
4.7 mm [0.187 in.] to and including 6.4 mm [0.25 in.]	122.0 [90]
6.6 mm [0.26 in.] to and including 12.9 mm [0.50 in.]	135.5 [100]
12.9 mm [0.51 in.] to and including 19.3 mm [0.75 in.]	203.2 [150]
19.3 mm [0.76 in.] to and including 25.4 mm [1.00 in.]	271.0 [200]
Greater than 25.4 mm [1.00 in.]	271.0 [200]

8.1.2 *Percent Gel, for Type I Tanks Only*—The percent gel level shall be determined using the test method described in 11.4. The percent gel level for Type I tanks on the inside 3.2 mm [0.125 in.] of the wall shall be a minimum of 60 %.

9. Dimensions and Tolerances

9.1 *General*—All dimensions will be taken with the tank in the vertical position, unfilled. Tank dimensions will represent the exterior measurements.

9.1.1 *Outside Diameter*—The tolerance for the outside diameter, including out of roundness, shall be ± 3 %.

9.1.2 *Shell Wall and Head Thickness*—The tolerance for average thickness at each elevation shall be -10 % of the design thickness on the low side and shall be unlimited on the

high side. The tolerance for individual audit readings shall be limited to -20 % of the design thickness. The total amount of surface area on the low side of the tolerance shall not exceed 10 % of the total surface area.

9.1.3 *Placement of Fittings*—The tolerance for fitting placements shall be 12.7 mm [0.5 in.] in elevation and 2° radial at ambient temperature.

10. Workmanship

10.1 Type I finished tank walls shall be free, as commercially practicable, of visual defects such as foreign inclusions, air bubbles, pinholes, pimples, crazing, cracking and delaminations that will impair the serviceability of the vessel. Fine bubbles are acceptable with Type II tanks to the degree to which they do not interfere with proper fusion of the resin melt.

10.2 Because of the differences in various resins used in this application and the molding conditions used, the interior surface characteristics may vary. The acceptable finish shall be predetermined by agreement between the molder and the buyer.

11. Test Methods

11.1 *Test Specimens*—Test specimens shall be taken from an area that is representative of the bottom side wall. If no representative sample cut-out area in the tank is available, test specimens shall be molded in a test mold. In either case, prior testing shall verify that the tank wall and the test specimen have equal impact resistance.

11.1.1 The test mold shall be constructed of the same type material and have the same wall thickness as the tank mold. The thickness of the specimen from a test mold shall be the same as the thickness of the bottom sidewall within the tolerances as defined in 9.1.2. The test mold shall be molded with each tank.

11.2 *Conditioning*—If requested, test specimens shall be conditioned at $23 \pm 2^\circ\text{C}$ [$73.4 \pm 3.6^\circ\text{F}$] and 50 ± 5 % relative humidity for not less than 40 h prior to testing in accordance with Procedure A of Practice D 618.

11.3 *Low-Temperature Impact Test:*

11.3.1 *Scope*—This test method is for the determination of the impact property of rotational-molded polyethylene tanks at low temperature. The test method is used on tanks molded from both crosslinked and non-crosslinked polyethylenes.

11.3.2 *Summary of Test Method*—Test specimens are cut from available areas on the tank and conditioned at -29°C [-20°F] for a specified time. A suitable type of test apparatus is shown in Fig. 1 and Fig. 2. The specimens are placed, inside-surface down, in the sample holder and immediately impacted from a prescribed height with a dart of specified weight and tip radius. The specimen is observed for failure on both surfaces. The test prescribes a minimum impact value that the specimen must pass.

11.3.3 *Significance and Use:*

11.3.3.1 The dart impact test at -29°C [-20°F] produces a value that is used as an indication of the quality of the tank. If the molding conditions were inadequate and a homogenous melt was not obtained, the impact will likely be low. Higher

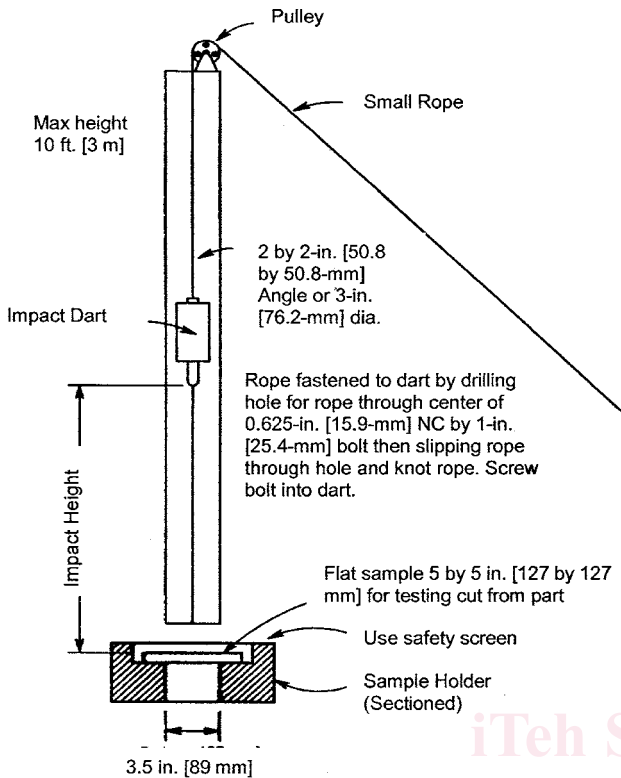

FIG. 1 Dart Drop Impact Test Apparatus

BOTH DARTS SIMILAR EXCEPT FOR LENGTH DIMENSIONS SHOWN

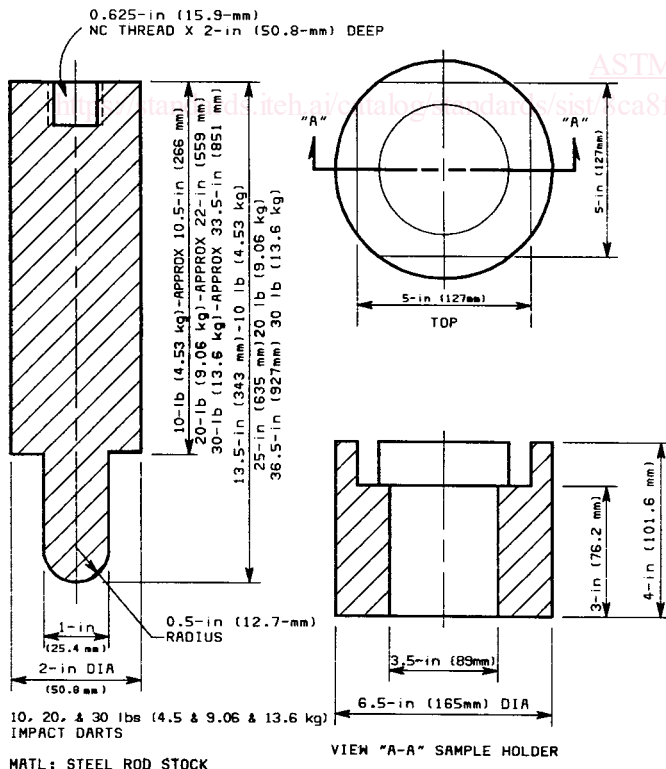

FIG. 2 Dart Drop Impact Test Apparatus

impact values are obtained with ideal molding conditions indicating that a quality part with good impact resistance has been molded.

11.3.3.2 The impact test gives a true indication of how well the tank was molded.

11.3.4 Procedure:

11.3.4.1 Cut specimens to loosely fit the 127 mm by 127 mm [5 in. by 5 in.] sample holder (See Fig. 2). Specimens shall be approximately 127 mm by 127 mm [5 in. by 5 in.], or the maximum size available. In those tanks where specimens of the above size are not available, the supplier must show correlation data between the smaller size and the recommended size.

11.3.4.2 Cool bath to -29°C [-20°F] by immersing small quantities of dry ice in isopropyl alcohol used as the bath medium or chill the specimens in a freezer if available. **Warning**—Care shall be exercised as the dry ice will agitate the solution violently.

NOTE 4—An alternative temperature for impact is -40°C [-40°F] or, in some cases, the service temperature. In applications that have a service temperature between -29°C [-20°F] and -40°C [-40°F], either the service temperature or -40°C [-40°F] shall be used. For applications that have a service temperature below -40°C [-40°F], the impact temperature shall be at or below the service temperature.

11.3.4.3 Immerse the specimens in the bath for a minimum of 30 min while maintaining the bath temperature. More immersion time is required for specimens greater than 6.4 mm [0.25 in.] thick or for specimens chilled in air instead of alcohol. A minimum of two hours is required for air chilled specimens.

11.3.4.4 Remove specimens from the freezer or bath one at a time. Within five seconds, release the dart and impact each specimen on the outer surface. Use the impact energy specified in 8.1.1 as calculated by multiplying the dart weight by the drop height (Fig. 1). The specimen shall not fail at the specified impact energy (see 3.2.1 for the definition of failure). Whenever possible, choose a dart weight that permits the drop height to be between 0.8 and 2.3 m [2.5 and 7.5 ft] in order to minimize the effect of velocity on the result of the test.

NOTE 5—Ductile failures indicate proper molding for Type I and Type II tanks, while cracking or shattering indicates improperly molded specimens. The test apparatus is shown in Fig. 1 and Fig. 2.

11.3.5 Report the Following Information:

- 11.3.5.1 Identification of the tank,
- 11.3.5.2 Date of test,
- 11.3.5.3 Impact energy used for the test in J [ft-lb], and
- 11.3.5.4 Pass or fail.

11.3.6 Precision and Bias:

11.3.6.1 Table 1 is based on a round robin conducted in 1991 in accordance with Practice E 691, involving two materials tested by seven laboratories and two materials tested by four laboratories. For each material, all of the samples were molded at one source. Each laboratory tested 20 specimens of a material on two different days under the same conditions.

11.3.6.2 Table 2 is based on a round robin conducted in 1988 in accordance with Practice E 691, involving two materials tested by seven laboratories. For each material, all the samples were prepared at one source, but the individual specimens were prepared at the laboratories that tested them.