



## Standard Test Methods and Practices for Emulsified Asphalts<sup>1</sup>

This standard is issued under the fixed designation D 244; the number immediately following the designation indicates the year of original adoption or, in the case of revision, the year of last revision. A number in parentheses indicates the year of last reapproval. A superscript epsilon ( $\epsilon$ ) indicates an editorial change since the last revision or reapproval.

*This standard has been approved for use by agencies of the Department of Defense.*

### 1. Scope

1.1 These test methods and practices, given under the headings titled Composition, Consistency, Stability, and Examination of Residue, cover the examination of asphalt emulsions composed principally of a semisolid or liquid asphaltic base, water, and an emulsifying agent. The test methods cover the following tests:

Test	Sections
Composition:	
Water Content	4-10
Residue and Oil Distillate by Distillation	See Test Method D 6997
Residue by Evaporation	See Test Method D 6934
Particle Charge of Cationic Emulsified Asphalts	11-16
Consistency:	
Viscosity (Saybolt Furol)	17-21
Stability:	
Demulsibility	See Test Method D 6936
Settlement	See Test Method D 6930
Cement Mixing	See Test Method D 6935
Sieve Test	See Test Method D 6933
Aggregate Coating	See Practice D 6998
Miscibility with Water	See Test Method D 6999
Freezing	See Practice D 6929
Coating Ability and Water Resistance	22-29
Storage Stability of Asphalt Emulsion	See Test Method D 6930
Examination of Residue	30-37
Identification Test for Rapid Setting Cationic Emulsified Asphalt	38-45
Identification of Cationic Slow Set Emulsions	46-51
Field Coating Test on Emulsified Asphalts	52-57
Emulsified Asphalt/Job Aggregate Coating Test	58-63
Density of Emulsified Asphalt	See Test Method D 6937
Residue by Low-Temperature Vacuum Distillation	64-69

1.2 The values stated in SI units are to be regarded as the standard. The values given in parentheses are for information only.

1.3 This standard does not purport to address all of the safety concerns, if any, associated with its use. It is the responsibility of the user of this standard to establish appropriate safety and health practices and determine the applicability of regulatory limitations prior to use.

### 2. Referenced Documents

#### 2.1 ASTM Standards:<sup>2</sup>

- C 778 Specification for Standard Sand
- D 5 Test Method for Penetration of Bituminous Materials
- D 70 Test Method for Specific Gravity and Density of Semi-Solid Bituminous Materials (Pycnometer Method)
- D 86 Test Method for Distillation of Petroleum Products at Atmospheric Pressure
- D 88 Test Method for Saybolt Viscosity
- D 113 Test Method for Ductility of Bituminous Materials
- D 128 Test Methods for Analysis of Lubricating Grease
- D 139 Test Method for Float Test for Bituminous Materials
- D 140 Practice for Sampling Bituminous Materials
- D 977 Specification for Emulsified Asphalt
- D 2042 Test Method for Solubility of Asphalt Materials in Trichloroethylene
- D 2397 Specification for Cationic Emulsified Asphalt
- D 3289 Test Method for Density of Semi-Solid and Solid Bituminous Materials (Nickel Crucible Method)
- D 6929 Practice for Freezing of Emulsified Asphalts
- D 6930 Test Method for Settlement and Storage Stability of Emulsified Asphalts
- D 6933 Test Method for Oversized Particles in Emulsified Asphalts (Sieve Test)
- D 6934 Test Method for Residue of Emulsified Asphalt
- D 6935 Test Method for Determining Cement Mixing of Emulsified Asphalt
- D 6936 Test Method for Determining Demulsibility of Emulsified Asphalt
- D 6937 Test Method for Determining Density of Emulsified Asphalt
- D 6997 Test Method for Distillation of Emulsified Asphalt

<sup>1</sup> These test methods are under the jurisdiction of ASTM Committee D04 on Road and Paving Materials and are the direct responsibility of Subcommittee D04.42 on Emulsified Asphalt Tests.

Current edition approved Dec. 1, 2004. Published December 2004. Originally approved in 1926. Last previous edition approved in 2000 as D 244 – 00.

<sup>2</sup> For referenced ASTM standards, visit the ASTM website, www.astm.org, or contact ASTM Customer Service at service@astm.org. For *Annual Book of ASTM Standards* volume information, refer to the standard's Document Summary page on the ASTM website.

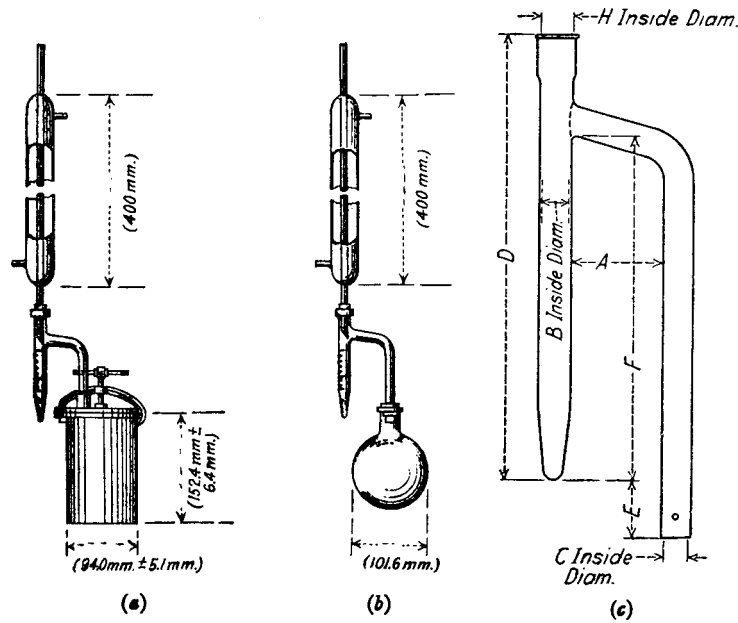

A = 45 to 55 mm  
 B = 14 to 16 mm  
 C = 12 to 16 mm  
 D = 235 to 255 mm

E = 25 to 38 mm  
 F = 186 to 194 mm  
 H = 18 to 19 mm

FIG. 1 Apparatus for Determining Water Content

- D 6998 Practice for Evaluating Aggregate Coating Using Emulsified Asphalts
- D 6999 Practice for Miscibility of Emulsified Asphalts
- E 1 Specification for ASTM Liquid-in-Glass Thermometers
- E 11 Specification for Wire Cloth and Sieves for Testing Purposes
- E 145 Specification for Gravity-Convection and Forced-Ventilation Ovens

### 3. Sample Conditioning for Testing

3.1 All emulsions with viscosity requirements of 50°C should be heated to 50 ± 3°C in the original sample container in a 71°C water bath or oven. The container should be vented to relieve pressure. After the sample reaches 50 ± 3°C, stir the sample to achieve homogeneity.

## COMPOSITION

### WATER CONTENT

#### 4. Scope

4.1 This test method covers the procedure for determining the water content of an emulsified asphalt by reflux distillation using a water trap.

#### 5. Significance and Use

5.1 This test method measures the amount of water present in the emulsified asphalt, as distinguished from either bitumen or petroleum solvent.

#### 6. Apparatus and Materials

6.1 *Metal Still*—The metal still (Fig. 1(a)) shall be a vertical cylindrical vessel, preferably of copper, having a faced flange at the top to which the head is tightly attached by means of a

clamp. The head shall be made of metal, preferably brass or copper, and shall be provided with a tubulation 25.4 mm (1 in.) in inside diameter.

6.2 *Glass Still*—The glass still (Fig. 1(b)) shall be a short-neck, round-bottom flask, made of well-annealed glass, and having an approximate capacity of 500 mL.

6.3 *Heat Source*—The heat source used with the metal still shall be a ring gas burner of 100-mm (4-in.) inside diameter or an electric mantle heater. The heat source for the glass still shall be either an ordinary gas burner or an electric heater.

6.4 *Condenser*—The condenser shall be a water-cooled reflux glass-tube type, having a jacket not less than 400 mm in length, with an inner tube 9.5 to 12.7 mm in outside diameter. The end of the condenser shall be ground to an angle of 30 ± 5° from the vertical axis of the condenser.

6.5 *Trap*—The trap shall be made of annealed glass constructed in accordance with Fig. 1(c) and shall be graduated in 0.10-mL divisions from 0 to 2 mL, and in 0.20-mL divisions from 2 to 25 mL.

6.6 *Solvent*—Xylol or other petroleum distillate conforming to the following distillation requirements: 98 % distills between 120 and 250°C. This distillation shall be conducted in accordance with Test Method D 86.

## 7. Sample

7.1 Obtain a representative sample of the material for test using standard procedures as specified in Practice D 140.

NOTE 1—The difficulties in obtaining representative samples for this determination are unusually great, so that the importance of sampling cannot be too strongly emphasized.

## 8. Procedure

8.1 When the material to be tested contains less than 25 % water, place  $100 \pm 0.1$  g of sample in the still. When the material contains more than 25 % water, use a  $50 \pm 0.1$ -g sample. Thoroughly mix the sample to be tested with 200 mL of solvent by swirling, taking proper care to avoid any loss of material.

8.2 Connect the still, trap, and condenser by means of tight-fitting corks as shown in Fig. 1(a) or (b). Adjust the end of the condenser in the trap to a position which will allow the end to be submerged to a depth of not more than 1 mm below the surface of the liquid in the trap after distillation conditions have been established. When using the metal still, insert a heavy paper gasket, moistened with the solvent, between the lid and flange before attaching the clamp.

8.3 When the ring burner is used with the metal still, place it about 76.2 mm above the bottom of the still at the beginning of the distillation, and gradually lower it as the distillation proceeds. Regulate the heat so that the condensate falls from the end of the condenser at a rate of from 2 to 5 drops per second. Continue the distillation at the specified rate until no water is visible on any part of the apparatus and a constant volume of water is obtained in the trap. Remove any persistent ring of condensed water in the condenser tube by increasing the rate of distillation for a few minutes.

## 9. Calculation and Report

9.1 Calculate the water content as follows:

$$\text{Water content, \%} = (A/B) \times 100 \quad (1)$$

where:

A = volume of water in trap, mL, and

B = original weight of sample, g.

9.2 Report the result as "... water weight percent, ASTM D 244."

## 10. Precision and Bias

10.1 The following criteria should be used for judging the acceptability of results (95 % probability):

10.1.1 Duplicate results by the same operator should not be considered suspect unless they differ by more than the following amount:

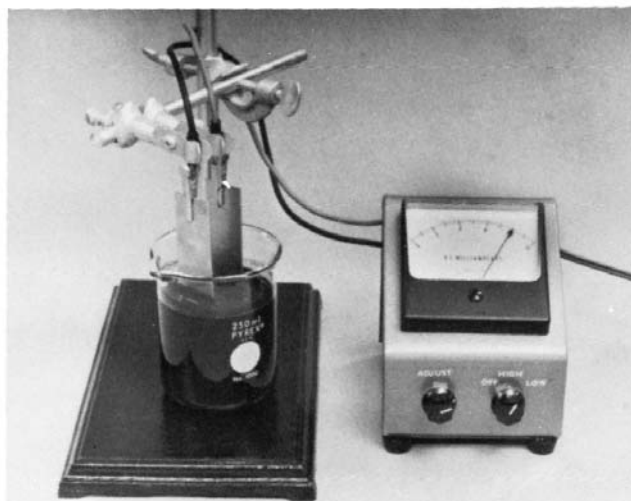

FIG. 2 Particle Charge Tester

Water Content, weight %  
30 to 50

Repeatability, weight %  
0.8

10.1.2 The results submitted by each of two laboratories should not be considered suspect unless they differ by more than the following amount:

Water Content, weight %  
30 to 50

Reproducibility, weight %  
2.0

## PARTICLE CHARGE OF CATIONIC EMULSIFIED ASPHALTS

### 11. Scope

11.1 This test method is used to identify cationic emulsions. Positively charged particles are classified as cationic.

### 12. Significance and Use

12.1 Cationic emulsions are identified by the migration of the particles to a negatively charged electrode (cathode) by means of a direct current.

### 13. Apparatus

13.1 *Current Source*, of 12-V dc, a milliammeter, and a variable resistor (see Fig. 2 and Fig. 3).

13.2 *Electrodes*—Two stainless steel plates, 25.4 mm by 101.6 mm insulated from each other and rigidly held parallel 12.7 mm apart (see Fig. 4).

13.3 *Insulator*—Polytetrafluoroethylene resin square rod, virgin electrical grade, 12.7 mm thick (see Fig. 4).

13.4 *Beaker*, 250 mL.

13.5 *Glass Rod*, 101.6 mm long and 6.35 mm thick or other suitable material or device that is capable of insulating and suspending the electrode assembly in emulsion.

13.6 *Water Bath*, capable of maintaining the required testing temperature within the limits specified in this test method.

13.7 *Thermometer*, ASTM No. 19C or 19F conforming to the requirements of Specification E 1.

### 14. Procedure

14.1 Heat the emulsion to be tested to  $50 \pm 3^\circ\text{C}$ , in a  $71 \pm 3^\circ\text{C}$  water bath. Stir the emulsion thoroughly to ensure uniformity of temperature.

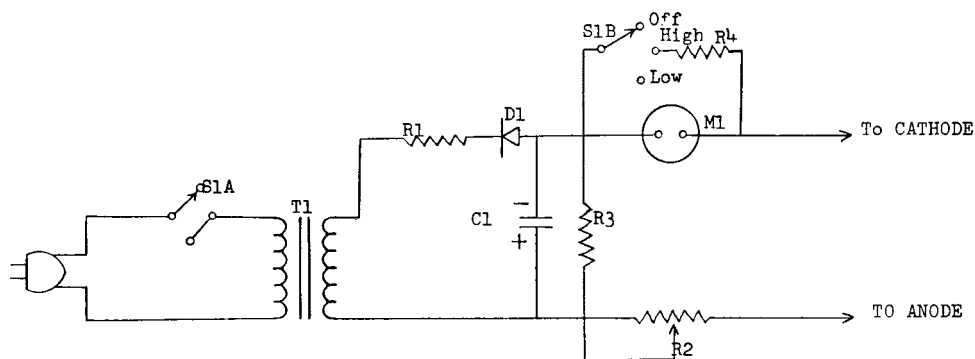

C1—500  $\mu$ F 25-V capacitor  
 D1—silicon diode  
 R1—47  $\Omega$ , 1-W resistor  
 R2—5000  $\Omega$  potentiometer  
 R3—6800  $\Omega$ , 1/4-W resistor

R4—meter shunt (determined by type of meter used)  
 S1—2-pole, 3-position rotary switch  
 T1—12.6-V filament transformer  
 M1—0 to 10-mA milliammeter

FIG. 3 Particle Charge Tester Circuit Diagram

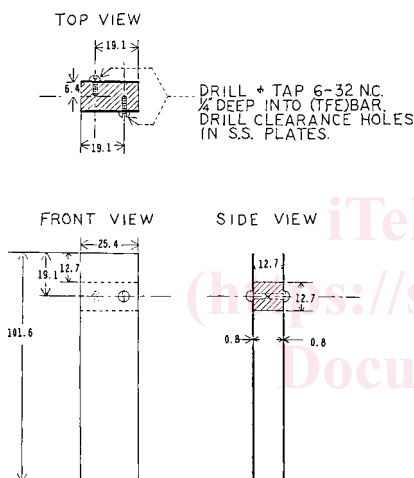

FIG. 4 Insulator

14.2 Pour the emulsion to be tested into the 250-mL beaker to a height that will allow the electrodes to be suspended 25.4 mm in the emulsion. To facilitate suspension of the electrodes, insert the glass rod or equivalent between the two electrodes under the insulator. Place the ends of the glass rod or equivalent on the two opposite top edges of the beaker. An apparatus capable of manual height adjustment to insulate and suspend electrode assembly in emulsion may be used if desired.

14.3 Connect the electrodes, that have been properly cleaned (Note 2), to the dc source.

NOTE 2—New electrodes and electrodes to be re-used should be cleaned in the following sequence:

1. Wash with distilled water,
2. Wash with a suitable asphalt solvent,

3. Wash with isopropyl or ethyl alcohol, and
4. Wash with distilled water.

14.4 Adjust the current to at least 8 mA with the variable resistor and start timing with a suitable timing device. (The 8 mA is a minimum current value. Higher current levels may be specified. The current used shall be reported.)

14.5 When the current drops to 2 mA or at the end of 30 min, whichever occurs first, disconnect the current source and gently wash the electrodes with a smooth, thin stream of distilled water.

14.6 Observe the asphalt deposit on the electrodes. A cationic emulsion will deposit a discernible amount of asphalt on the cathode (negative electrode) while the anode (positive electrode) will be relatively clean. Any evidence of a deposit of asphalt on the cathode which is clearly discernible when compared to the anode is to be considered passing.

NOTE 3—If the emulsion does not produce conclusive results and it is a cationic slow-setting grade, then proceed to Section 46, "Identification of Cationic Slow-Set Emulsion."

## 15. Report

15.1 Report the following information:

- 15.1.1 Level of current used, and
- 15.1.2 Whether the tested emulsion passes or fails as defined in 14.6.

## 16. Precision and Bias

16.1 This test method, which requires subjective evaluation of test results and reporting of only two possible conditions, does not lend itself readily to a conventional statistical round-robin exercise. At present, there is no precision and bias statement for this test method.



**VISCOSITY**
**17. Scope**

17.1 This test method utilizes the Saybolt Furol viscometer to measure the consistency of an asphalt emulsion. It is applicable to all the emulsions specified in Specifications **D 977** and **D 2397**.

**18. Significance and Use**

18.1 Viscosity has significance in the use of asphalt emulsions because it is a property which affects their utility. When used in application types of construction, the material must be thin enough to be uniformly applied through the spray bar of distributor, yet thick enough so that it will not flow from the crown or grade of the road. For mixing grade emulsions, the viscosity may affect mixability and resulting thickness of film on the aggregate. The viscosity of many emulsions is affected by shear. Therefore, strict adherence to test procedure is necessary to achieve precision.

**19. Apparatus**

19.1 *Viscometer*—A Saybolt Furol viscometer conforming to the requirements specified in Test Method **D 88**.

19.2 *Sieve*—A 850- $\mu$ m sieve or a 20-mesh strainer of wire cloth, framed or unframed.

19.3 *Thermometers*—ASTM No. 17C or 17F for tests at 25°C and ASTM No. 19F or 19C for tests at 50°C, conforming to the requirements of Specification **E 1**.

19.4 *Water Bath*, capable of maintaining the required testing temperature within the limits specified in Table 2 of Test Method **D 88**.

**20. Procedure**

20.1 *Tests at 25°C*—Stir the sample thoroughly without incorporating bubbles and pour it into a 118-mL bottle. Place the bottle in the water bath at 25°C for 30 min and mix the sample in the bottle by inverting it several times slowly enough to prevent bubble formation. Pour the sample into the viscometer through the 850- $\mu$ m sieve or 20-mesh strainer, allowing a small portion to flow through the outlet tube to waste. Place the cork in position, fill the viscometer and, without again stirring the sample, determine the viscosity as prescribed in Test Method **D 88**.

20.2 *Tests at 50°C*—Clean and dry the viscometer and insert the cork. Heat the emulsion sample to  $122 \pm 5^\circ\text{F}$  ( $50 \pm 3^\circ\text{C}$ ) in a  $160 \pm 5^\circ\text{F}$  ( $71 \pm 3^\circ\text{C}$ ) water bath or oven. Stir the sample thoroughly without incorporating bubbles, and then pour approximately 100 mL into a 400-mL glass beaker. Immerse the bottom of the beaker containing the emulsion approximately 2 in. (50.8 mm) below the level of a  $160 \pm 5^\circ\text{F}$  ( $71 \pm 3^\circ\text{C}$ ) water bath. Hold the beaker upright and stir the emulsion with a wide circular motion at a rate of 60 revolutions per minute with the thermometer to obtain uniform temperature distribution. Avoid incorporation of bubbles. Heat the emulsion in the water bath to  $124.5 \pm 0.5^\circ\text{F}$  ( $51.4 \pm 0.3^\circ\text{C}$ ). Immediately pour the emulsion through the 850- $\mu$ m (No. 20) sieve or 20-mesh

strainer into the viscometer until it is above the overflow rim. Stir the emulsion in the viscometer at 60 revolutions per minute with the thermometer until the test temperature is attained, avoiding bubble formation. Adjust the bath temperature until the emulsion temperature remains constant for 1 min at  $50 \pm 0.05^\circ\text{C}$ . Withdraw the thermometer. Quickly remove the excess emulsion from the gallery with a suction pipet. Determine the viscosity as described in Test Method **D 88**. Report the results to the nearest full second.

NOTE 4—While the Saybolt Furol viscometer is not used for petroleum products and lubricants when the time of flow is less than 25 s, this instrument is satisfactory for testing emulsified asphalt when the time of flow is not less than 20 s.

**21. Precision and Bias**

21.1 The following criteria should be used for judging the acceptability of results (95 % probability):

21.1.1 Duplicate results by the same operator should not be considered suspect unless they differ by more than the following amount:

Test Temperature, °C	Viscosity, s	Repeatability, % of the mean
25	20 to 100	5
50	75 to 400	9.6

21.1.2 The results submitted by each of two laboratories should not be considered suspect unless they differ by more than the following amount:

Test Temperature, °C	Viscosity, s	Reproducibility, % of the mean
25	20 to 100	15
50	75 to 400	21

**COATING ABILITY AND WATER RESISTANCE**
**22. Scope**

22.1 This test method is intended to aid in the identification of asphalt emulsions suitable for mixing with coarse graded calcareous aggregates. It can be applied to other aggregates. (See **Note 5**).

**23. Significance and Use**

23.1 This test method covers the determination of the ability of an asphalt emulsion to (1) coat an aggregate thoroughly, (2) withstand a mixing action while remaining as a film on the aggregate, and (3) resist the washing action of water after completion of the mixing.

**24. Apparatus**

24.1 *Mixing Pan*—A white-enamelled kitchen saucepan with handle, of approximately 3-L capacity.

24.2 *Mixing Blade*—A putty knife with a 31.8 by 88.9-mm steel blade with rounded corners. A 254.0-mm kitchen mixing spoon may be used as an alternative.

24.3 *Sieves*—Standard 19.0-mm and 4.75-mm sieves conforming to Specification **E 11**.

24.4 *Constant-Head Water-Spraying Apparatus*—An apparatus for applying tap water in a spray under a constant head of

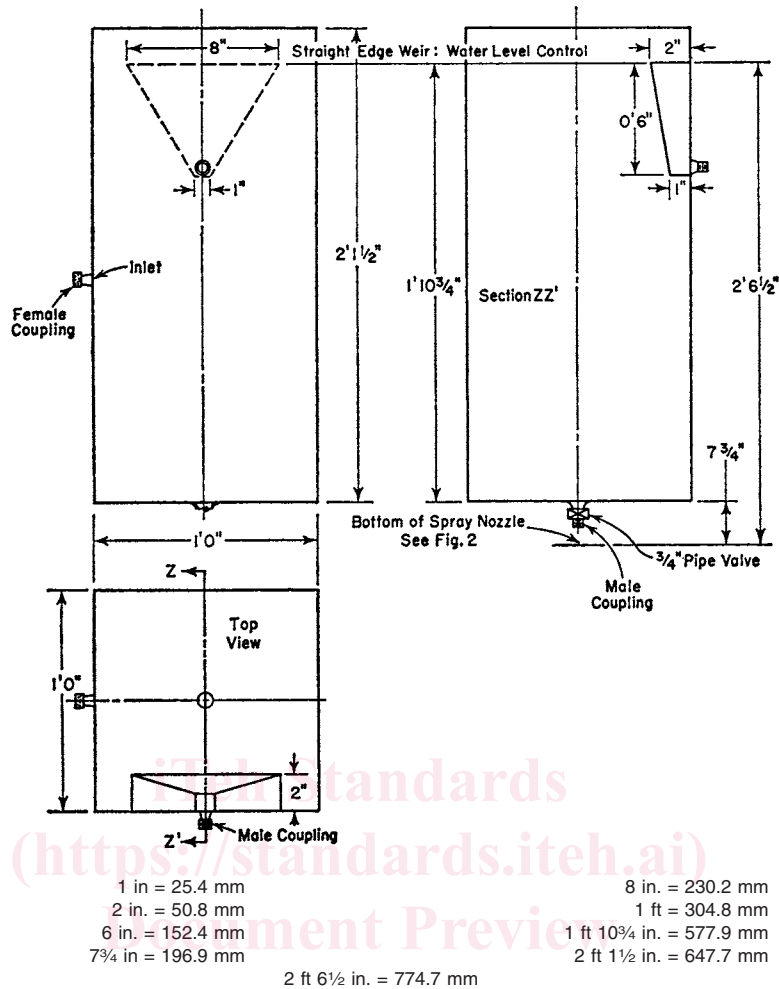

NOTE 1—Use galvanized steel sheeting for the tank. All joints and fitting attachments shall be soldered and shall be watertight. All couplings shall be standard brass garden hose fittings. The 19-mm pipe valve shall be placed as close as possible to the bottom of the tank, allowing space to shut off the valve. The tank shall be placed on a suitable stand, so that the distance from the bottom of the spray head to the top of the test sample is 0.914 m ± 25.4 mm.

FIG. 5 Constant-Head Flow Tank

774.7 mm (Figs. 5 and 6). The water shall issue from the apparatus in a low-velocity spray.

24.5 *Thermometer*—An ASTM Low Softening Point Thermometer 15F (or 15C), having a range from -2 to 80°C and conforming to the requirements in Specification E 1.

24.6 *Balance*, capable of weighing 1000 g to within ±0.1 g.

24.7 *Pipet*, of 10-mL capacity.

## 25. Materials

25.1 *Aggregate*—Standard reference aggregate<sup>3</sup> shall be a laboratory-washed and air-dried limestone aggregate graded to pass the 19.0-mm sieve and be retained on the 4.75-mm sieve.

NOTE 5—Aggregates other than limestone may be used provided calcium carbonate is omitted throughout the test method. Laboratory washing and air-drying of such aggregates shall also be omitted.

<sup>3</sup> Limestone from the Monon Stone Co. of Monon, IN, has been found suitable as reference aggregate.

25.2 *Calcium Carbonate*—Chemically pure, precipitated calcium carbonate (CaCO<sub>3</sub>) shall be used as a dust to be mixed with the standard reference aggregate.

25.3 *Water*—Tap water of not over 250 ppm CaCO<sub>3</sub> hardness for spraying over the sample.

## 26. Sample

26.1 The sample shall be representative of the asphalt emulsion to be tested.

## 27. Procedure for Tests with Dry Aggregate

27.1 Carry out the test at 23.9 ± 5.5°C.

27.2 Weigh 461 g of the air-dried, graded reference aggregate in the mixing pan.

27.3 Weigh 4.0 g of CaCO<sub>3</sub> dust in the mixing pan and mix with the 461 g of aggregate for approximately 1 min by means of a mixing blade to obtain a uniform film of dust on the aggregate particles.

NOTE 6—The total weight of aggregate and dust shall equal 465 g. If no