Tissue paper and tissue products
Part 9:
Determination of ball burst strength

Papier tissu et produits en tissu

*Partie 9: Détermination de la résistance à l'éclatement, méthode à la
balle*

iTeh STANDARD PREVIEW
(standards.iteh.ai)

ISO 12625-9:2005

<https://standards.iteh.ai/catalog/standards/sist/58ad41b3-e747-448c-9e3a-855ad5ef2409/iso-12625-9-2005>



PDF disclaimer

This PDF file may contain embedded typefaces. In accordance with Adobe's licensing policy, this file may be printed or viewed but shall not be edited unless the typefaces which are embedded are licensed to and installed on the computer performing the editing. In downloading this file, parties accept therein the responsibility of not infringing Adobe's licensing policy. The ISO Central Secretariat accepts no liability in this area.

Adobe is a trademark of Adobe Systems Incorporated.

Details of the software products used to create this PDF file can be found in the General Info relative to the file; the PDF-creation parameters were optimized for printing. Every care has been taken to ensure that the file is suitable for use by ISO member bodies. In the unlikely event that a problem relating to it is found, please inform the Central Secretariat at the address given below.

iTeh STANDARD PREVIEW
(standards.iteh.ai)

[ISO 12625-9:2005](https://standards.iteh.ai/catalog/standards/sist/58ad41b3-e747-448c-9e3a-855ad5ef2409/iso-12625-9-2005)

<https://standards.iteh.ai/catalog/standards/sist/58ad41b3-e747-448c-9e3a-855ad5ef2409/iso-12625-9-2005>

© ISO 2005

All rights reserved. Unless otherwise specified, no part of this publication may be reproduced or utilized in any form or by any means, electronic or mechanical, including photocopying and microfilm, without permission in writing from either ISO at the address below or ISO's member body in the country of the requester.

ISO copyright office
Case postale 56 • CH-1211 Geneva 20
Tel. + 41 22 749 01 11
Fax + 41 22 749 09 47
E-mail copyright@iso.org
Web www.iso.org

Published in Switzerland

Contents

Page

Foreword	iv
Introduction	v
1 Scope	1
2 Normative references	1
3 Terms and definitions	1
4 Principle	2
5 Apparatus	2
6 Conditioning	4
7 Preparation of test pieces	4
8 Procedure	4
9 Calculation	5
10 Test report	5
11 Precision	5
Bibliography	7

iTeh STANDARD PREVIEW
(standards.iteh.ai)

[ISO 12625-9:2005](https://standards.iteh.ai/catalog/standards/sist/58ad41b3-e747-448c-9e3a-855ad5ef2409/iso-12625-9-2005)

<https://standards.iteh.ai/catalog/standards/sist/58ad41b3-e747-448c-9e3a-855ad5ef2409/iso-12625-9-2005>

Foreword

ISO (the International Organization for Standardization) is a worldwide federation of national standards bodies (ISO member bodies). The work of preparing International Standards is normally carried out through ISO technical committees. Each member body interested in a subject for which a technical committee has been established has the right to be represented on that committee. International organizations, governmental and non-governmental, in liaison with ISO, also take part in the work. ISO collaborates closely with the International Electrotechnical Commission (IEC) on all matters of electrotechnical standardization.

International Standards are drafted in accordance with the rules given in the ISO/IEC Directives, Part 2.

The main task of technical committees is to prepare International Standards. Draft International Standards adopted by the technical committees are circulated to the member bodies for voting. Publication as an International Standard requires approval by at least 75 % of the member bodies casting a vote.

Attention is drawn to the possibility that some of the elements of this document may be the subject of patent rights. ISO shall not be held responsible for identifying any or all such patent rights.

ISO 12625-9 was prepared by the European Committee for Standardization (CEN) Technical Committee CEN/TC 172, Pulp, paper and board, in collaboration with Technical Committee ISO/TC 6, *Paper, board and pulps*, Subcommittee SC 2, *Test methods and quality specifications for paper and board*, in accordance with the Agreement on technical cooperation between ISO and CEN (Vienna Agreement).

ISO 12625 consists of the following parts, under the general title *tissue paper and tissue product*:

- *Part 1: General guidance on terms* [ISO 12625-9:2005](https://standards.iteh.ai/catalog/standards/sist/58ad41b3-e747-448c-9e3a-855ad5e72409/iso-12625-9-2005)
- *Part 3: Determination of thickness, bulking thickness and apparent bulk density*
- *Part 4: Determination of tensile strength, stretch at break and tensile energy absorption*
- *Part 5: Determination of wet tensile strength*
- *Part 6: Determination of grammage*
- *Part 7: Determination of optical properties*
- *Part 8: Water absorption time and water absorption capacity, basket immersion test method*
- *Part 9: Determination of ball burst strength*

Introduction

This part of ISO 12625 is applicable to tissue paper and tissue products. In principle, application to other paper types is possible, but not covered by this part of ISO 12625.

iTeh STANDARD PREVIEW (standards.iteh.ai)

[ISO 12625-9:2005](https://standards.iteh.ai/catalog/standards/sist/58ad41b3-e747-448c-9e3a-855ad5ef2409/iso-12625-9-2005)

<https://standards.iteh.ai/catalog/standards/sist/58ad41b3-e747-448c-9e3a-855ad5ef2409/iso-12625-9-2005>

iTeh STANDARD PREVIEW
(standards.iteh.ai)

[ISO 12625-9:2005](https://standards.iteh.ai/catalog/standards/sist/58ad41b3-e747-448c-9e3a-855ad5ef2409/iso-12625-9-2005)

<https://standards.iteh.ai/catalog/standards/sist/58ad41b3-e747-448c-9e3a-855ad5ef2409/iso-12625-9-2005>

Tissue paper and tissue products

Part 9: Determination of ball burst strength

1 Scope

This part of ISO 12625 specifies a test method for the determination of the resistance to mechanical penetration (ball burst strength procedure) of tissue paper and tissue products.

It is expressly stated that the detection of impurities and contraries in tissue paper and tissue products should be applied according to ISO 15755.

For the determination of moisture content in tissue paper and tissue products, ISO 287 should be applied.

2 Normative references

The following referenced documents are indispensable for the application of this document. For dated references, only the edition cited applies. For undated references, the latest edition of the referenced document (including any amendments) applies.

ISO 186, *Paper and board — Sampling to determine average quality*

ISO 187, *Paper, board and pulps — Standard atmosphere for conditioning and testing and procedure for monitoring the atmosphere and conditioning of samples*

ISO 7500-1, *Metallic materials — Verification of static uniaxial testing machines — Part 1: Tension/compression testing machines — Verification and calibration of the force-measuring system*

ISO 12625-1, *Tissue paper and tissue products — Part 1: General guidance on terms*

ISO 12625-6, *Tissue paper and tissue products — Part 6: Determination of grammage*

3 Terms and definitions

For the purposes of this document, the terms and definitions given in ISO 12625-1 and the following apply.

3.1 grammage

g

mass of a unit area of tissue paper or tissue product as determined by the procedure specified in ISO 12625-6

NOTE The grammage is expressed in grams per square metre (g/m^2).

**3.2
bursting force**

F

maximum force, that a test piece of a tissue paper or tissue products can withstand under the test conditions, applied at right angles to its surface

NOTE The bursting force is expressed in millinewtons (mN).

**3.3
burst index**

X

bursting force of the tissue paper or tissue product divided by the grammage of the conditioned sample determined by the standard method of test

NOTE The burst index is expressed in millinewtons square metre per gram (mN·m²/g).

4 Principle

The test consists of measuring the resistance to a mechanical penetration (burst) of the test piece under test, when it is rigidly clamped at the periphery between two concentric annular rings, and is forced to a bulge in a direction perpendicular to the plane wherein the test piece is fixed and centred by a ball of a hard non-deformable, highly polished material, that is fixed in a suitable mechanism for moving at constant speed.

5 Apparatus

iTeh STANDARD PREVIEW
(standards.iteh.ai)

5.1 Clamping system

The clamping system is designed to clamp the test piece firmly and uniformly between two concentric annular plane, parallel surfaces. The clamping rings can be activated by, for example, a mechanical or a pneumatic system during testing.

The clamping pressure shall be sufficient to prevent slippage during the test, however, avoiding damaging the test pieces.

The clamping surfaces of the clamping rings are coated with a commercial grade of a band made of a suitable plastic material, typically 1,5 mm to 2 mm thick having a IRHD hardness (International Rubber Hardness Degree) of 75 ± 5 .

The edge of the coated band shall be coincident with the inner diameter of the clamping rings and be at least 12,5 mm wide.

The internal diameter of the two concentric rings shall be $(89,0 \pm 0,2)$ mm.

For the dimensions of the clamping system, see Figure 1.

Dimensions in millimetres

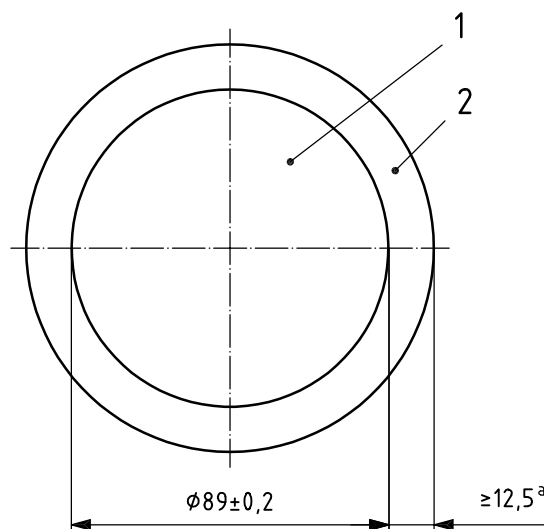
**Key**

- 1 test area
- 2 clamp ring

^a Suitable coated band.

Figure 1 — Principle of the clamping system
(standards.iteh.ai)

5.2 Penetration system

ISO 12625-9:2005

The penetration (burst) system consists of a spherical penetration made from any hard, non-deformable, highly polished material with the following dimensions:

- diameter: $(16 \pm 0,05)$ mm;
- sphericity: better than 1 micron.

The penetration ball is permanently affixed to the end of a $(9,0 \pm 1)$ mm solid hard rod, designed to transmit the force applied to the ball to a suitable load cell and force-measuring system, and will be centred with the annular clamps.

5.3 Force-measuring system

The force-measuring system shall measure the loads with a class of machine range of 1 or better and shall be calibrated and verified in accordance with the requirements of ISO 7500-1. The readout system shall have a display that shows the maximum force at burst and record.

5.4 Drive mechanism

The drive mechanism shall consist of a static uniaxial testing machine with a suitable mechanism for moving the assembly up and down at constant rate in a direction perpendicular to the plane in which the test piece is fixed. This mechanism may provide for a variable or fixed speed of movement. The penetration test speed shall be (125 ± 5) mm/min.