Elektromagnetna združljivost in zadeve v zvezi z radijskim spektrom (ERM) - Pomorski osebni javljalniki lokacije majhne moči z uporabo AIS - 1. del: Tehnične karakteristike in merilne metode

Electromagnetic compatibility and Radio spectrum Matters (ERM) - Maritime low power personal locating beacons employing AIS - Part 1: Technical characteristics and methods of measurement

iTeh STANDARD PREVIEW
(standards.iteh.ai)

[SIST EN 303 098-1 V1.2.1:2014](https://standards.iteh.ai/catalog/standards/sist/31b9e3e1-f19c-45a1-b601-ac8d0dfb3908/sist-en-303-098-1-v1-2-1-2014)
<https://standards.iteh.ai/catalog/standards/sist/31b9e3e1-f19c-45a1-b601-ac8d0dfb3908/sist-en-303-098-1-v1-2-1-2014>

Ta slovenski standard je istoveten z: EN 303 098-1 Version 1.2.1

ICS:

33.060.01	Radijske komunikacije na splošno	Radiocommunications in general
33.100.01	Elektromagnetna združljivost na splošno	Electromagnetic compatibility in general
47.020.70	Navigacijska in krmilna oprema	Navigation and control equipment

SIST EN 303 098-1 V1.2.1:2014 **en**

iTeh STANDARD PREVIEW
(standards.iteh.ai)

SIST EN 303 098-1 V1.2.1:2014

<https://standards.iteh.ai/catalog/standards/sist/31b9e3e1-f19c-45a1-b601-ac8d0dfb3908/sist-en-303-098-1-v1-2-1-2014>

ETSI EN 303 098-1 V1.2.1 (2014-09)



**Electromagnetic compatibility and
Radio spectrum Matters (ERM);
Maritime low power personal locating devices employing AIS;
Part 1: Technical characteristics and methods of measurement**

<https://standards.iteh.ai/catalog/standards/sist/31b9e3e1-f19c-45a1-b601-ac8d0dfb3908/sist-en-303-098-1-v1-2-1-2014>

Reference

DEN/ERM-TG26-100-1

Keywords

maritime, radio, SAR, testing

ETSI

650 Route des Lucioles
F-06921 Sophia Antipolis Cedex - FRANCE

Tel.: +33 4 92 94 42 00 Fax: +33 4 93 65 47 16

Siret N° 348 623 562 00017 - NAF 742 C
Association à but non lucratif enregistrée à la
Sous-Préfecture de Grasse (06) N° 7803/88

iTeh STANDARD PREVIEW
(standards.iteh.ai)

SIST EN 303 098-1 V1.2.1:2014

<https://standards.iteh.ai/catalog/standards/sist/31b9e3e1-f19c-45a1-b601-ac8d0dfb39/etsi-en-303-098-1-v1-2-1-2014>
Important notice

The present document can be downloaded from:

<http://www.etsi.org>

The present document may be made available in electronic versions and/or in print. The content of any electronic and/or print versions of the present document shall not be modified without the prior written authorization of ETSI. In case of any existing or perceived difference in contents between such versions and/or in print, the only prevailing document is the print of the Portable Document Format (PDF) version kept on a specific network drive within ETSI Secretariat.

Users of the present document should be aware that the document may be subject to revision or change of status. Information on the current status of this and other ETSI documents is available at

<http://portal.etsi.org/tb/status/status.asp>

If you find errors in the present document, please send your comment to one of the following services:

http://portal.etsi.org/chaicor/ETSI_support.asp

Copyright Notification

No part may be reproduced or utilized in any form or by any means, electronic or mechanical, including photocopying and microfilm except as authorized by written permission of ETSI.

The content of the PDF version shall not be modified without the written authorization of ETSI.

The copyright and the foregoing restriction extend to reproduction in all media.

© European Telecommunications Standards Institute 2014.

All rights reserved.

DECT™, **PLUGTESTS™**, **UMTS™** and the ETSI logo are Trade Marks of ETSI registered for the benefit of its Members. **3GPP™** and **LTE™** are Trade Marks of ETSI registered for the benefit of its Members and of the 3GPP Organizational Partners.

GSM® and the GSM logo are Trade Marks registered and owned by the GSM Association.

Contents

Intellectual Property Rights	7
Foreword.....	7
Modal verbs terminology.....	7
1 Scope	8
2 References	8
2.1 Normative references	8
2.2 Informative references.....	9
3 Definitions, symbols and abbreviations	9
3.1 Definitions	9
3.2 Symbols.....	9
3.3 Abbreviations	9
4 General requirements	10
4.1 Construction	10
4.1.1 Categories of equipment	11
4.2 Controls	11
4.3 Indicators.....	11
4.4 Identifier (user ID).....	11
4.5 Labelling.....	12
4.5.1 Labelling Requirements.....	12
4.6 Instructions	12
4.7 Power source	12
4.7.1 Battery requirements	12
4.7.2 Battery capacity	13
4.7.3 Safety precautions.....	13
5 Technical requirements	13
5.1 General	13
5.2 AIS transmission characteristics.....	13
5.2.1 AIS messages.....	13
5.2.1.1 Active mode	14
5.2.1.2 Test mode.....	14
5.2.2 Synchronization	14
5.2.2.1 Active mode	14
5.2.2.2 Test mode.....	14
5.2.3 GNSS position source.....	14
5.2.3.1 UTC.....	15
5.2.3.2 UTC parameters storage.....	15
5.2.4 Required settings	15
5.2.5 Minimum transmitter performance characteristics	16
5.2.6 VHF Data Link (VDL) Access	16
5.2.6.1 Active mode	16
5.2.6.2 Test mode.....	17
6 General conditions of measurement	17
6.1 Conformity testing.....	17
6.2 Test Frequencies.....	17
6.3 Identifier (user ID).....	17
6.4 Artificial Antenna.....	17
6.5 Test signals	18
6.5.1 Standard test signal number 1	18
6.5.2 Standard test signal number 2	18
6.5.3 Standard test signal number 3	18
6.5.4 Reference timing signal	18
6.6 Measurement uncertainty and interpretation of the measured results	18

6.6.1	Measurement uncertainty.....	18
6.6.2	Interpretation of the measurement results.....	19
6.7	Test conditions power sources and ambient temperatures.....	19
6.7.1	Normal and extreme test conditions.....	19
6.7.2	Test power source.....	19
6.8	Normal test conditions.....	19
6.8.1	Normal temperature and humidity.....	19
6.8.2	Normal test voltage.....	19
6.9	Extreme test conditions.....	19
6.9.1	Extreme temperatures.....	19
6.9.1.1	Procedure for tests at extreme temperatures.....	20
6.9.2	Extreme test voltages.....	20
6.9.2.1	Upper extreme test voltage.....	20
6.9.2.2	Lower extreme test voltage.....	20
7	Environmental tests.....	20
7.1	Introduction.....	20
7.2	Procedure.....	20
7.3	Performance check.....	20
7.4	Drop test.....	20
7.4.1	Definition.....	20
7.4.2	Test conditions.....	21
7.4.3	Method of measurement.....	21
7.4.4	Requirements.....	21
7.5	Temperature tests.....	21
7.5.1	Definition.....	21
7.5.2	Dry heat test.....	21
7.5.2.1	Method of measurement.....	21
7.5.2.2	Requirements.....	22
7.5.3	Damp heat test.....	22
7.5.3.1	Method of measurement.....	22
7.5.3.2	Requirements.....	22
7.5.4	Low temperature test.....	22
7.5.4.1	Method of measurement.....	22
7.5.4.2	Requirements.....	22
7.5.5	Low temperature battery endurance test.....	23
7.5.5.1	Method of measurement.....	23
7.5.5.2	Requirements.....	23
7.6	Vibration test.....	23
7.6.1	Definition.....	23
7.6.2	Method of measurement.....	23
7.6.3	Requirement.....	24
7.7	Corrosion test.....	24
7.7.1	Definition.....	24
7.7.2	Method of measurement.....	24
7.7.3	Requirements.....	24
7.8	Thermal shock test.....	25
7.8.1	Definition.....	25
7.8.2	Method of measurement.....	25
7.8.3	Requirements.....	25
7.9	Buoyancy test.....	25
7.9.1	Definition.....	25
7.9.2	Method of measurement.....	25
7.9.3	Requirements.....	25
7.10	Compass safe distance test.....	26
7.10.1	Definition.....	26
7.10.2	Method of measurement.....	26
7.10.3	Requirements.....	26
7.11	Solar radiation test.....	27
7.11.1	Definition.....	27
7.11.2	Method of measurement.....	27
7.11.3	Requirements.....	27

7.12	Oil resistance test.....	27
7.12.1	Definition.....	27
7.12.2	Method of measurement	27
7.12.3	Requirements	28
7.13	Protection of the transmitter	28
7.13.1	Definition.....	28
7.13.2	Method of measurement	28
7.13.3	Requirement.....	28
8	Tests on the AIS transmitter	28
8.1	Frequency error	28
8.1.1	Definition.....	28
8.1.2	Method of measurement	28
8.1.3	Limit	29
8.2	Conducted Power	29
8.2.1	Definition.....	29
8.2.2	Method of measurement under normal test conditions	29
8.2.3	Limit	29
8.3	Maximum Effective Radiated Power (ERP).....	29
8.3.1	Definition.....	29
8.3.2	Method of measurement	29
8.3.3	Limits.....	30
8.4	Transmitter spectrum mask	30
8.4.1	Definition.....	30
8.4.2	Method of measurement	30
8.4.3	Limit	31
8.5	Transmitter transient behaviour (output power).....	31
8.5.1	Definition.....	31
8.5.2	Method of measurement	32
8.5.3	Limit	33
8.6	Transmitter Transient Behaviour (frequency deviation)	33
8.6.1	Definition.....	33
8.6.2	Method of measurement	33
8.6.3	Limit	34
8.7	Synchronization accuracy.....	34
8.7.1	Definition.....	34
8.7.2	Method of measurement	34
8.7.3	Limit	35
8.8	Spurious emissions	36
8.8.1	Definition.....	36
8.8.2	Method of measurement	36
8.8.3	Limit	36
9	VDL Link layer tests	36
9.1	Active mode tests	36
9.1.1	Method of measurement	36
9.1.2	Initialization period - Required results.....	37
9.1.3	Message content of Message 1 - Required results	37
9.1.4	Message content of Message 14 - Required results	37
9.1.5	Transmission schedule for Message 1 - Required results	37
9.1.6	Communication state of Message 1 - Required results	38
9.1.7	Transmission schedule of Message 14 - Required results.....	38
9.1.8	Transmission with lost GNSS - Required results.....	38
9.2	Test mode tests with GNSS data available	39
9.2.1	Method of measurement	39
9.2.2	Required results	39
9.3	Test mode tests without GNSS data available.....	39
9.3.1	Method of measurement	39
9.3.2	Required results	39
Annex A (normative):	Radiated measurements	40
A.1	Test sites and general arrangements for measurements involving the use of radiated fields.....	40

A.1.1	Anechoic chamber	40
A.1.2	Anechoic chamber with a ground plane	41
A.1.3	OATS	42
A.1.4	Test antenna.....	43
A.1.5	Substitution antenna	43
A.1.6	Measuring antenna	44
A.2	Guidance on the use of radiation test sites	44
A.2.1	Verification of the test site	44
A.2.2	Preparation of the EUT.....	44
A.2.3	Power supplies to the EUT.....	44
A.2.4	Volume control setting for analogue speech tests	44
A.2.5	Range length.....	45
A.2.6	Site preparation	45
A.3	Coupling of signals.....	46
A.3.1	General	46
A.3.2	Data signals	46
A.4	Standard position.....	46
A.4.1	Artificial human support	46
A.4.2	Float-free support	47
Annex B (normative):	Locating device message bursts	48
B.1	Active mode	48
B.2	Test mode	49
B.3	Default message field values.....	50
Annex C (informative):	Bibliography.....	51
History		52

[SIST EN 303 098-1 V1.2.1:2014](https://standards.iteh.ai/catalog/standards/sist/31b9e3e1-f19c-45a1-b601-ac8d0dfb3908/sist-en-303-098-1-v1-2-1-2014)

<https://standards.iteh.ai/catalog/standards/sist/31b9e3e1-f19c-45a1-b601-ac8d0dfb3908/sist-en-303-098-1-v1-2-1-2014>

Intellectual Property Rights

IPRs essential or potentially essential to the present document may have been declared to ETSI. The information pertaining to these essential IPRs, if any, is publicly available for **ETSI members and non-members**, and can be found in ETSI SR 000 314: "*Intellectual Property Rights (IPRs); Essential, or potentially Essential, IPRs notified to ETSI in respect of ETSI standards*", which is available from the ETSI Secretariat. Latest updates are available on the ETSI Web server (<http://ipr.etsi.org>).

Pursuant to the ETSI IPR Policy, no investigation, including IPR searches, has been carried out by ETSI. No guarantee can be given as to the existence of other IPRs not referenced in ETSI SR 000 314 (or the updates on the ETSI Web server) which are, or may be, or may become, essential to the present document.

Foreword

This European Standard (EN) has been produced by ETSI Technical Committee Electromagnetic compatibility and Radio spectrum Matters (ERM).

The present document is part 1 of a multi-part deliverable covering the Electromagnetic compatibility and Radio spectrum Matters (ERM); Maritime low power personal locating devices employing AIS, as identified below:

Part 1: "Technical characteristics and methods of measurement";

Part 2: "Harmonized EN covering the essential requirements of article 3.2 of the R&TTE Directive";

iTeh STANDARD PREVIEW

National transposition dates

Date of adoption of this EN:	1 September 2014
Date of latest announcement of this EN (doa):	31 December 2014
Date of latest publication of new National Standard or endorsement of this EN (dop/e):	30 June 2015
Date of withdrawal of any conflicting National Standard (dow):	30 June 2016

Modal verbs terminology

In the present document "**shall**", "**shall not**", "**should**", "**should not**", "**may**", "**may not**", "**need**", "**need not**", "**will**", "**will not**", "**can**" and "**cannot**" are to be interpreted as described in clause 3.2 of the [ETSI Drafting Rules](#) (Verbal forms for the expression of provisions).

"**must**" and "**must not**" are **NOT** allowed in ETSI deliverables except when used in direct citation.

1 Scope

The present document lays down the minimum requirements for low power maritime personal locating devices employing AIS and an integrated GNSS receiver to provide the locating function. The present document incorporates the relevant provisions of the International Telecommunication Union (ITU) radio regulations [i.3] included in Recommendation ITU-R M.1371-5 [1].

For this application, both the radiated power and the length of time of operation are limited to enable the equipment to be sufficiently small and light to be worn comfortably at all times and to limit the operating range to a local area.

2 References

References are either specific (identified by date of publication and/or edition number or version number) or non-specific. For specific references, only the cited version applies. For non-specific references, the latest version of the reference document (including any amendments) applies.

Referenced documents which are not found to be publicly available in the expected location might be found at <http://docbox.etsi.org/Reference>.

NOTE: While any hyperlinks included in this clause were valid at the time of publication, ETSI cannot guarantee their long term validity.

2.1 Normative references

The following referenced documents are necessary for the application of the present document.

- [1] Recommendation ITU-R M.1371-5 (02/2014): "Technical characteristics for an automatic identification system using time-division multiple access in the VHF maritime mobile band".
<https://standards.iteh.ai/catalog/standards/sist/31b9e3e1-f19c-45a1-b601-ac3041b3908/sist-en-303-098-1-v1-2-1-2014>
- [2] ETSI TR 100 028 (all parts) (V1.4.1): "Electromagnetic compatibility and Radio spectrum Matters (ERM); Uncertainties in the measurement of mobile radio equipment characteristics".
- [3] ETSI TR 102 273-7 (2001): "Electromagnetic compatibility and Radio spectrum Matters (ERM); Improvement on Radiated Methods of Measurement (using test site) and evaluation of the corresponding measurement uncertainties; Part 7: Artificial human beings".
- [4] CENELEC EN 61108-1 (2003): "Maritime navigation and radiocommunication equipment and systems - Global navigation satellite systems (GNSS) - Part 1: Global positioning system (GPS) - Receiver equipment - Performance standards, methods of testing and required test results".
- [5] CENELEC EN 61108-2 (1998): "Maritime navigation and radiocommunication equipment and systems - Global navigation satellite systems (GNSS) - Part 2: Global navigation satellite system (GLONASS) - Receiver equipment - Performance standards, methods of testing and required test results".
- [6] CENELEC EN 61108-3 (2010): "Maritime navigation and radiocommunication equipment and systems - Global navigation satellite systems (GNSS) - Part 3: Galileo receiver equipment - Performance requirements, methods of testing and required test results".
- [7] Recommendation ITU-T O.153 (10/1992): "Basic parameters for the measurement of error performance at bit rates below the primary rate".
- [8] IMO ANNEX 11 - RESOLUTION MSC.149(77) - (adopted on 3 June 2003): "Adoption of the revised performance standards for survival craft portable two-way VHF radiotelephone apparatus".

2.2 Informative references

The following referenced documents are not necessary for the application of the present document but they assist the user with regard to a particular subject area.

- [i.1] ETSI TR 102 273 (Parts 2, 3 and 4) (V1.2.1): "Electromagnetic compatibility and Radio spectrum Matters (ERM); Improvement on Radiated Methods of Measurement (using test site) and evaluation of the corresponding measurement uncertainties".
- [i.2] ANSI C63.5-2006: "American National Standard for Calibration of Antennas Used for Radiated Emission Measurements in Electro Magnetic Interference".
- [i.3] ITU-R Radio Regulations 2012.

3 Definitions, symbols and abbreviations

3.1 Definitions

For the purposes of the present document, the following terms and definitions apply:

active mode: activated mode, transmitting in an emergency situation

test mode: self testing mode, not involved in a genuine emergency

UTC lock: GNSS has precisely locked to UTC so that it can determine SOTDMA slot timing correctly.

UTC parameters: "Coordinated Universal Time (UTC) offset parameters" GNSS data that contains leap second offset information

3.2 Symbols

For the purposes of the present document, the following symbols apply:

ε	permittivity
σ	conductivity
λ	wavelength
cSt	centi-Stokes
dB	decibel
div	division
S	Siemens
μT	microtesla

3.3 Abbreviations

For the purposes of the present document, the following abbreviations apply:

AIS	Automatic Identification System
ASTM	American Society for Testing and Materials
CIRM	Comité International Radio-Maritime
COG	Course Over Ground
CRC	Cyclic Redundancy Check
CSP	Channel SPacing
CW	Continuous Wave
EIRP	Effective Isotropic Radiated Power
ERP	Effective Radiated Power
EUT	Equipment Under Test
GLONASS	GLObal NAVigation Satellite System (Russian system)
GMSK	Gaussian Minimum Shift Keying

GNSS	Global Navigation Satellite System
GPS	Global Positioning System
GTRF	Galileo Terrestrial Reference Frame system
IMO MSC	International Maritime Organization Maritime Safety Committee
ISO	International Organization for Standardization
ITRF	International Terrestrial Reference Frame
ITU-R	International Telecommunication Union Radiocommunication sector
ITU-T	International Telecommunication Union Telecommunication sector
MOB	Man Over-Board
NRZI	Non Return to Zero, Inverted
OATS	Open Area Test Site
PPS	Pulses Per Second
PZ-90	Parametry Zemli 1990
RAIM	Receiver Autonomous Integrity Monitoring
RF	Radio Frequency
SOG	Speed Over Ground
SOTDMA	Self-Organized Time Division Multiple Access
TDMA	Time Division Multiple Access
UTC	Coordinated Universal Time
VDL	VHF Data Link
VHF	Very High Frequency
VSWR	Voltage Standing Wave Ratio
WGS-84	World Geodetic System 1984

4 General requirements

4.1 Construction

The manufacturer shall provide evidence that all requirements in clause 4 are fulfilled.

In all respects, the mechanical and electrical design and the construction and finish of the equipment shall conform with good engineering practice.

The equipment shall be designed to minimize the risk of internal and external damage during use or stowage.

The exterior of the equipment shall have no sharp edges or projections that could easily damage inflatable rafts or injure personnel.

The general construction and method of operation shall provide a high degree of proof against inadvertent operation due to magnetic influences, handling, stowage and transit, whilst still providing a simple means of operation in an emergency.

The equipment shall be portable, lightweight, compact and be designed as one integral unit. The locating device shall derive its energy from a battery forming a part of the equipment and incorporate a permanently attached antenna which may be either fixed length or extendible.

The locating device may be fitted with a test facility by which the functioning of the transmitter and battery can be easily tested without the use of any external equipment.

The equipment shall be capable of being used by an unskilled person.

The locating device shall be watertight to a depth of 1 m (see clause 7.13).

The equipment shall not be unduly affected by sea water or oil and shall be resistant to deterioration by prolonged exposure to sunlight.

A substantial part of the equipment shall be of highly visible yellow or orange colour to assist visual location.

4.1.1 Categories of equipment

Two categories are defined:

- Category 1 locating devices shall have sufficient positive buoyancy to float in fresh water.
- Category 2 locating devices intended to be incorporated into or attached to a buoyancy aid are not required to float.

Category 1 locating devices that can float free may have a lanyard to attach them to a person or life vest. Where a lanyard is employed it shall meet the requirements of IMO MSC.149(77) [8], paragraph 2.3.11. The user manual or instructions shall include necessary information to allow the user to properly attach the locating device lanyard.

The user manual or instructions for Category 2 devices shall include necessary information to allow the user to fit or attach the locating device to a buoyancy aid.

4.2 Controls

The equipment shall be initially activated by the use of two simple, but independent mechanical actions, neither of which on its own shall activate the equipment. The second mechanical action may be replaced by an immersion sensor. Where the second action is replaced by an immersion sensor then the first action shall be an arm function thus to ensure the device is armed for automatic activation when submerged.

It shall only be possible to activate the equipment after a seal or other mechanical restraint has been removed from the first mechanical action. For devices without an arm function it shall not be possible to reattach a removed seal or restraint. After activation it shall be simple to de-activate the equipment and the means to deactivate the equipment shall be clearly marked.

The switch that operates any test facility (clause 4.1) shall be so designed that it returns automatically to the off-position when released.

4.3 Indicators

The equipment shall be provided with a visual and/or audible indication that signals are being emitted. The indicator shall be sufficiently bright to be seen in bright sunlight. Except when operating in test mode the indicator shall not be green in colour.

The indicator shall clearly distinguish the following states:

- (i) The locating device has been activated and is waiting for GNSS data.
- (ii) The locating device has GNSS data and is transmitting in active mode.
- (iii) The locating device is undergoing test and is transmitting in test mode.
- (iv) The locating device has completed a test or has been de-activated.

4.4 Identifier (user ID)

The locating device shall have an identifier to distinguish it from other AIS devices.

The User ID for a personal search and rescue locating device is 972xyyyy, where xx = manufacturer ID 01 to 99; yyyy = the sequence number 0000 to 9999. Manufacturers IDs are issued by CIRM. Manufacturers shall only use manufacturer IDs that have been issued to them by CIRM, except for testing purposes where the ID xx=00 can be used (see clause 6.3).

After being programmed by the manufacturer, it shall not be possible for the user to change the identifier of the locating device.

The user ID shall be held in non-volatile memory.

4.5 Labelling

The equipment shall be provided with a label, or labels, permanently affixed to the exterior of the equipment, containing the information described hereunder.

4.5.1 Labelling Requirements

- user ID of the equipment (see clause 4.4) and manufacturer serial number;
- type designation of the equipment with prefix AIS-MOB;
- adequate instructions to enable the equipment to be activated and de-activated;
- the type of battery as specified by the manufacturer of the locating device;
- a warning to not block the GNSS antenna;
- the compass safe distance as measured in clause 7.10;
- a warning to the effect that the locating device should not be operated except in an emergency;
- the date on which the battery will need to be replaced. Simple means shall be provided for changing this date when the battery is replaced. The battery replacement date marked on the locating device should be the date specified in clause 4.7.1.

4.6 Instructions

Necessary operating instructions shall be provided with the equipment. These should include the following warnings:

- "WARNING - An AIS-MOB Man overboard device is only intended for short range signalling to an AIS receiver installed onboard your own vessel. It will not directly alert the emergency services or other vessels."
- "WARNING - This equipment is not intended for routine tracking of persons or property. This includes tracking of divers."
- "WARNING - If self-test is performed more frequently than once a month, then battery life may be reduced."

4.7 Power source

4.7.1 Battery requirements

The type of battery and designation specified by the manufacturer for use in the equipment shall be clearly and indelibly marked on the equipment.

The manufacturer should establish a useful life and an expiry date for primary (non-rechargeable) batteries. The useful life is the period of time after the date of battery manufacture that the battery will continue to meet the input power requirements of the locating device, over the entire specified operating temperature range. The following losses shall be included (at a temperature of $+20\text{ °C} \pm 5\text{ °C}$):

- a) self-testing monthly with GNSS data available;
- b) self-discharge of the battery;
- c) stand-by loads.

The expiry date of the battery shall be the battery installation date plus no more than half the useful life of the battery. The battery shall have a minimum useful life of at least two years. The installation date shall be no more than one year from the date of manufacture of the battery. The battery shall be clearly and durably marked with its date of manufacture. The locating device shall be clearly marked with the expiry date of the battery.

4.7.2 Battery capacity

The battery, after having met the requirements of clause 4.7.1 shall have sufficient remaining capacity to power an activated locating device and keep it transmitting for at least 12 hours at a temperature of $-20\text{ °C} \pm 3\text{ °C}$.

4.7.3 Safety precautions

Provisions shall be made for protecting the equipment from damage due to the accidental reversal of polarity of the battery.

5 Technical requirements

5.1 General

When activated the locating device shall be capable of transmitting messages that indicate the position of a person in the water. The transmitted messages shall be compatible with existing AIS installations. The transmitted messages shall be recognized and displayed by AIS receivers in the reception range of the transmitter, and clearly distinguish the transmitter as a personal Man Over-Board (MOB) locating device. AIS TDMA Synchronization shall be UTC direct; the locating device does not require an AIS receiver.

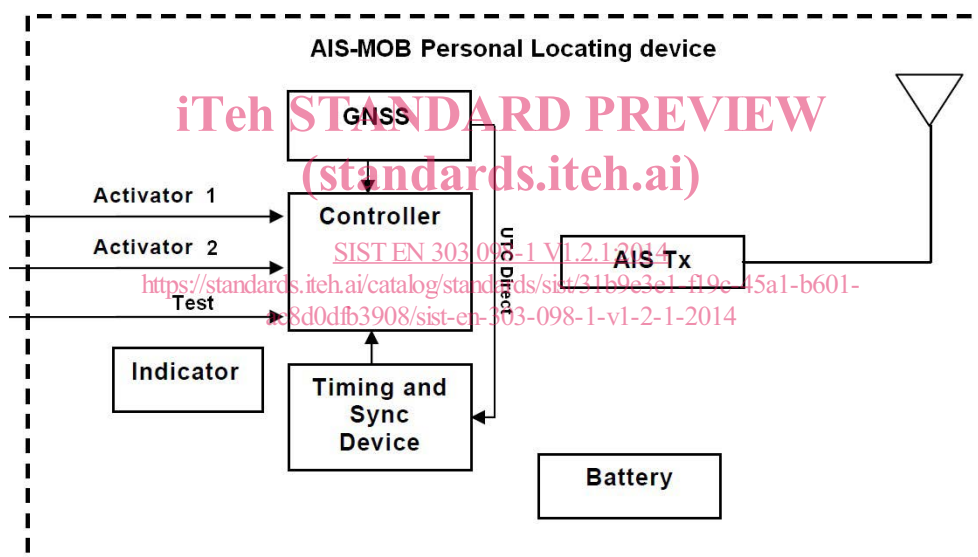

Figure 1: Functional block diagram of personal locating device

5.2 AIS transmission characteristics

The AIS Tx transmits using modified SOTDMA on two channels AIS1 and AIS2. The GNSS receiver, e.g. a GPS receiver, determines the current position of the locating device and facilitates TDMA synchronization in the UTC direct mode.

The locating device shall shutdown automatically if, under a fault condition, the transmitter remains permanently keyed for more than 2 seconds. This shutdown shall be independent of the operating software.

5.2.1 AIS messages

The locating device shall broadcast Message 1 and Message 14, as defined in Recommendation ITU-R M.1371-5 [1]. The content of the messages differs for active transmissions (active mode) and test transmissions (test mode). The combination of these messages in burst sequences is detailed in annex B.