



**SLOVENSKI STANDARD**  
**SIST-TP CEN/TR 16589:2014**  
**01-januar-2014**

---

**Laboratorijska oprema - Naprava za zajem z gibljivo roko**

Laboratory installations - Capture devices with articulated extract arm

Laboreinrichtungen - Absaugvorrichtungen mit beweglichem Arm

Installation de laboratoire - Dispositif de capture avec bras articulé d'extraction

**Ta slovenski standard je istoveten z: CEN/TR 16589:2013**

[SIST-TP CEN/TR 16589:2014](https://standards.iteh.ai/catalog/standards/sist/ae5548a0-8ba5-4767-87b4-5284ff49655f/sist-tp-cen-tr-16589-2014)

<https://standards.iteh.ai/catalog/standards/sist/ae5548a0-8ba5-4767-87b4-5284ff49655f/sist-tp-cen-tr-16589-2014>

**ICS:**

71.040.10	Kemijski laboratoriji. Laboratorijska oprema	Chemical laboratories. Laboratory equipment
-----------	---	--

**SIST-TP CEN/TR 16589:2014**

**en,fr,de**

**iTeh STANDARD PREVIEW**  
**(standards.iteh.ai)**

[SIST-TP CEN/TR 16589:2014](#)

<https://standards.iteh.ai/catalog/standards/sist/ae5548a0-8ba5-4767-87b4-5284ff49655f/sist-tp-cen-tr-16589-2014>

ICS 71.040.10

English Version

**Laboratory installations - Capture devices with articulated extract arm**

Installation de laboratoire - Dispositif de capture avec bras articulé d'extraction

Laboreinrichtungen - Absaugvorrichtungen mit beweglichem Arm

This Technical Report was approved by CEN on 10 September 2013. It has been drawn up by the Technical Committee CEN/TC 332.

CEN members are the national standards bodies of Austria, Belgium, Bulgaria, Croatia, Cyprus, Czech Republic, Denmark, Estonia, Finland, Former Yugoslav Republic of Macedonia, France, Germany, Greece, Hungary, Iceland, Ireland, Italy, Latvia, Lithuania, Luxembourg, Malta, Netherlands, Norway, Poland, Portugal, Romania, Slovakia, Slovenia, Spain, Sweden, Switzerland, Turkey and United Kingdom.

**iTeh STANDARD PREVIEW  
(standards.iteh.ai)**[SIST-TP CEN/TR 16589:2014](https://standards.iteh.ai/catalog/standards/sist/ae5548a0-8ba5-4767-87b4-5284ff49655f/sist-tp-cen-tr-16589-2014)<https://standards.iteh.ai/catalog/standards/sist/ae5548a0-8ba5-4767-87b4-5284ff49655f/sist-tp-cen-tr-16589-2014>EUROPEAN COMMITTEE FOR STANDARDIZATION  
COMITÉ EUROPÉEN DE NORMALISATION  
EUROPÄISCHES KOMITEE FÜR NORMUNG**CEN-CENELEC Management Centre: Avenue Marnix 17, B-1000 Brussels**

<b>Contents</b>		Page
Foreword.....		3
1 <b>Scope</b> .....		4
2 <b>General description</b> .....		4
3 <b>Applications and installation</b> .....		6
4 <b>Manufacturers or suppliers</b> .....		7
5 <b>Performance metrics</b> .....		7
6 <b>Use</b> .....		8
6.1 <b>Routine use</b> .....		8
6.2 <b>Maintenance</b> .....		8
6.3 <b>Training</b> .....		8
<b>Bibliography</b> .....		9

## iTeh STANDARD PREVIEW (standards.iteh.ai)

[SIST-TP CEN/TR 16589:2014](https://standards.iteh.ai/catalog/standards/sist/ae5548a0-8ba5-4767-87b4-5284ff49655f/sist-tp-cen-tr-16589-2014)

<https://standards.iteh.ai/catalog/standards/sist/ae5548a0-8ba5-4767-87b4-5284ff49655f/sist-tp-cen-tr-16589-2014>

## Foreword

This document (CEN/TR 16589:2013) has been prepared by Technical Committee CEN/TC 332 "Laboratory equipment", the secretariat of which is held by DIN.

Attention is drawn to the possibility that some of the elements of this document may be the subject of patent rights. CEN [and/or CENELEC] shall not be held responsible for identifying any or all such patent rights.

## iTeh STANDARD PREVIEW (standards.iteh.ai)

[SIST-TP CEN/TR 16589:2014](https://standards.iteh.ai/catalog/standards/sist/ae5548a0-8ba5-4767-87b4-5284ff49655f/sist-tp-cen-tr-16589-2014)

<https://standards.iteh.ai/catalog/standards/sist/ae5548a0-8ba5-4767-87b4-5284ff49655f/sist-tp-cen-tr-16589-2014>

## 1 Scope

This Technical Report gives guidance regarding the selection, specification, installation and use of capture devices with articulated extract arm (abbreviated: AEAs) in laboratories. The informative material provided includes the general concept of AEAs, the variety of sub-types available, system installation issues, performance metrics and operational factors such as use, maintenance and training.

## 2 General description

Increasingly, capture devices with extract arm (known by a variety of names, e.g. “elephant trunks”, “snorkels”, “flexible exhausts” etc.) have been installed in laboratories mainly for the purpose of evacuating contaminants at source. They are used in low-hazard situations such as reduction of heat emitted by lab devices or capture of emissions, e.g. from HPLC equipment or in similar applications.

The capture performance of AEAs is largely dependent of the (spatial) relationship between the source of the gas, fume, vapour or dust requiring capture and the inlet hood (capture device) of an AEA. Capture devices with extract arms are for that reason only useful for example for very small pollution sources or when the pollution source is too large to reasonably be enclosed and has distinct points where the pollution might occur like a HPLC. There are today no available universal, readily-applied and normalised test methodologies for AEA's, although smoke is useful in visualising flows. For this reason care shall be taken in the selection, installation, and, critically, in-use arrangement of AEAs (as described in Clause 6). Some information can be found in VDI 2262 Part 4 (see Bibliography, [1]).

AEAs are available in a number of formats, a selection of which is illustrated in the diagrams that follow.

### iTeh STANDARD PREVIEW (standards.iteh.ai)

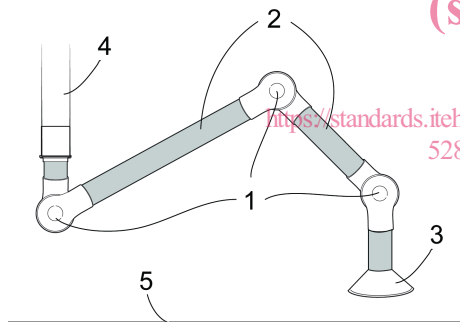

#### Key

- 1 spherical joints
- 2 rigid ductwork
- 3 inlet hood
- 4 exhaust
- 5 bench top

**Figure 1 — Rigid ducts with spherical joints exhausting at high level**

SIST-TP CEN/TR 16589:2014

<https://standards.iteh.ai/catalog/standards/sist/ae5548e0-8ba5-4767-87b4-5284ff49655f/sist-tp-cen-tr-16589-2014>

5284ff49655f/sist-tp-cen-tr-16589-2014

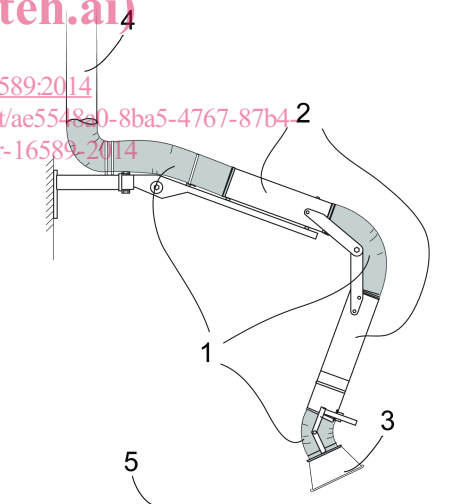

#### Key

- 1 joints from flexible ductwork
- 2 rigid ductwork
- 3 inlet hood
- 4 exhaust
- 5 bench top

**Figure 2 — Rigid ducts with flexible joints exhausting at high level**

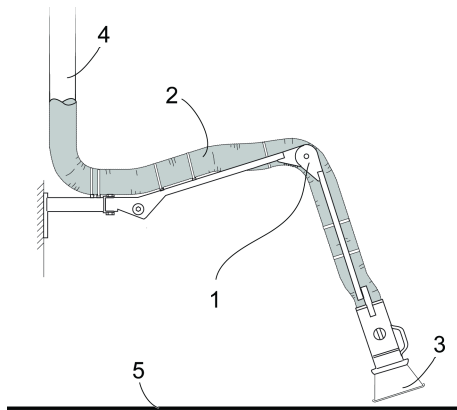
**Key**

- 1 articulated support frame
- 2 flexible ductwork
- 3 inlet hood
- 4 exhaust
- 5 bench top

**Figure 3 — Flexible ductwork exhausting at high level**

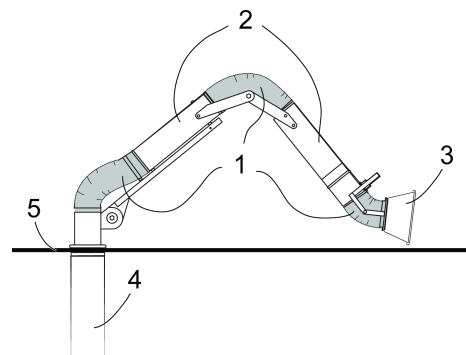
**Key**

- 1 joints from flexible ductwork
- 2 rigid ductwork
- 3 inlet hood
- 4 exhaust
- 5 bench top

**Figure 5 — Rigid ducts with flexible joints exhausting at low level**

**iTeh STANDARD PREVIEW**  
(standards.iteh.ai)

SIST-TP CEN/TR 16589:2014

<https://standards.iteh.ai/catalog/standards/sist/ae5548a0-8ba5-4767-87b4-5284ff49655f/sist-tp-cen-tr-16589-2014>

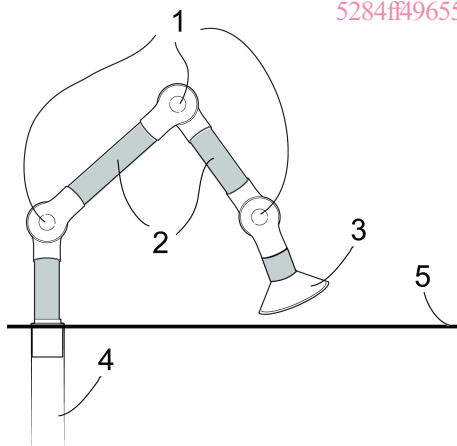
**Key**

- 1 spherical joints
- 2 rigid ductwork
- 3 inlet hood
- 4 exhaust
- 5 bench top

**Figure 4 — Rigid ducts with spherical joints exhausting at low level**

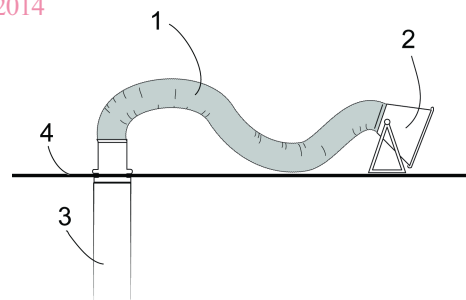
**Key**

- 1 flexible ductwork
- 2 inlet hood
- 3 exhaust
- 4 bench top

**Figure 6 — Flexible ductwork exhausting at low level**

## CEN/TR 16589:2013 (E)

The design shown in Figure 6 can also be used with high level exhaust systems, in which case the flexible duct merely hangs from ceiling level. The examples shown above relate to the most common approaches of mounting from above (high level) or bench-mounting. Further alternatives include sidewall mounting and support from an overhead services 'wing'.

Some typical arrangements of AEAs are illustrated below (generally being examples of Types 1 and 4).

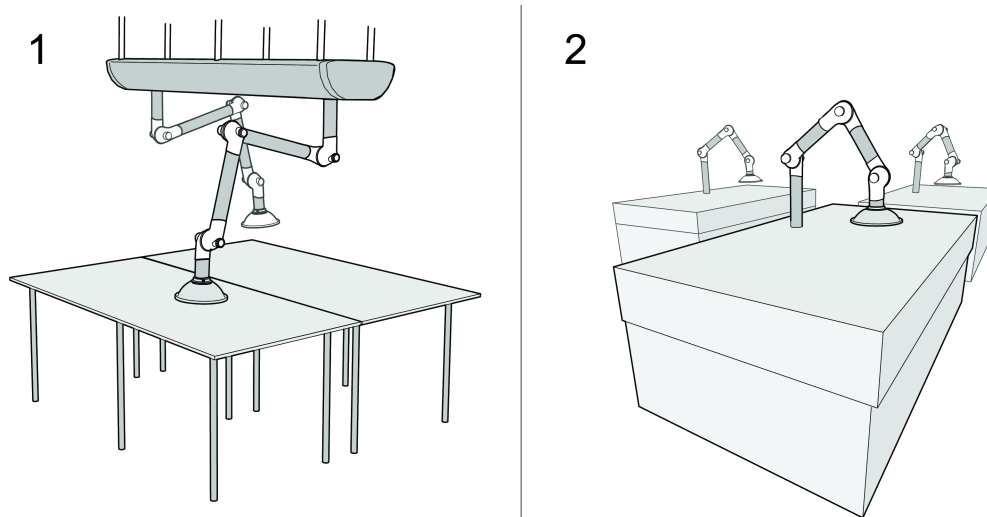
**Key**

- 1 over bench-mounted articulated arms
- 2 bench-mounted articulated arms

**iTeh STANDARD PREVIEW**  
(standards.iteh.ai)

**Figure 7 — Different arrangements of articulated extract arms**

<https://standards.iteh.ai/catalog/standards/sist/ae5548a0-8ba5-4767-87b4-5284ff49655f/sist-tp-cen-tr-16589-2014>

### 3 Applications and installation

Although the use of capture devices with articulated extract arm (AEAs) has some apparent immediate benefits in comparison with more traditional or conventional containment solutions, there are a number of issues that shall be considered and controlled. These include:

- a) The performance of an AEA is largely dependent on the proximity and location of the inlet opening relative to the source of contaminant and the extract velocity generated at that point. Any proposed installation shall, therefore, be capable of covering a range so that the inlet is appropriately close to the source and this may require the provision of a capture device suitable for its purpose (see Clause 4). To assure a good function over time it is also important that the capture device is easy to manoeuvre in position and that it stays put in its position over time.
- b) AEAs are for example employed in situations that involve nuisance activities, such as the removal of odors and other activities with low risk exposure. In each case, however, their application should nevertheless always be subject to a formal risk assessment.
- c) As an AEA is supposed to be used close to the contaminant's source, they should in general not be used for large diffuse sources.
- d) AEA capture devices are susceptible to disturbing airflows and therefore care needs to be taken when planning their installation.
- e) The buoyancy of the contaminant that the AEA is intended to capture will also have an impact on the effectiveness of an installation. For example, a capture device should preferably be placed above sources that are releasing contaminants that are less dense than ambient air and, conversely, below those that are releasing contaminants that are substantially more dense. These considerations can also have



substantial effects on the shape and extent of the capture device. Although simple cones are shown in the illustrations in Clause 2, more complex or tailor made forms are likely to show benefits in a variety of functional situations. Smoke can be useful in visualising this issue.

- f) The diameter of the ducted components of the arms is typically comparatively small in diameter. This results in relatively high air velocities together with associated considerations of air resistance and noise generation. This situation is further exacerbated in many cases by the incorporation of sections of flexible ductwork into the designs.
- g) As a consequence of the foregoing point, although the volume flow rates required by the AEAs are low, the resistances may represent a significant factor in the design of the overall extract ventilation system. If an AEA is connected into a main, 'common-user' extract system in a position at, or close to, the index leg of the ductwork installation, then a substantial energy cost will be paid for the use of the AEA. This difficulty can be addressed in a number of ways, including:
  - 1) Select a larger diameter of the extract arm to obtain a lower pressure drop and noise level.
  - 2) Select an AEA with low pressure drop.
  - 3) Do not locate the AEAs on a 'common-user' extract system but install a dedicated sub-system.
  - 4) As far as possible, any AEAs installed on a 'common-user' extract system should be connected at locations that do not increase the resistance or modify the location of the index leg (of the overall system when considered without the AEAs).

#### 4 Manufacturers or suppliers

### STANDARD PREVIEW

(standards.iteh.ai)

In discussions with manufacturers or suppliers of capture devices with articulated extract arm there are a number of aspects that may be usefully considered by potential users before the design and use of the devices is finalised. These include: [SIST-TP CEN/TR 16589:2014](https://standards.iteh.ai/catalog/standards/sist/ae5548a0-8ba5-4767-87b4-5284e4965718/sist-tp-cen-tr-16589-2014)

- a) The intended application should be discussed with the supplier to obtain a ventilation solution appropriate for the risk concerned.
- b) The supplier should be requested to supply, if at all possible, details of equivalent examples of AEA applications installed by other users.
- c) The manufacturer should be requested to supply engineering installation data regarding the AEA. This may include volume flow rates, pressure drops, acoustic information and capture efficiency.
- d) The materials of manufacture should be reviewed against factors such as resistance to chemical attack, suitability for fumigation, cleanability and robustness against physical damage.
- e) The provision of some form of airflow indicator could be a worthwhile enhancement to systems (see Clause 6 below).
- f) For special applications, the potential use of customised (to the particular situation) forms of capture devices may be considered with an objective of improving the efficiency of capture or partial containment.

#### 5 Performance metrics

As stated in Clause 3, the performance of an AEA is largely dependent on the proximity and location of the inlet opening relative to the source of contaminant and the capturing velocity generated at that point; besides, the buoyancy of the contaminant can also be an important factor. The capturing effectiveness at the source will thus also depend upon the characteristics of the release (e.g. release energy and release direction). As mentioned elsewhere in this Technical Report, the use of smoke, ideally used with the process in operation, can be useful to visualise the flows and to demonstrate the effectiveness of capture at different flow rates.