**Internal combustion engines — Piston
rings —**

**Part 2:
Half keystone rings made of cast iron**

*Moteurs à combustion interne — Segments de piston —
Partie 2: Segments demi-trapézoïdaux fabriqués en fonte moulée*

**iTeh STANDARD PREVIEW
(standards.iteh.ai)**

ISO 6624-2:2003

<https://standards.iteh.ai/catalog/standards/sist/7d34df60-6a47-4fa7-b44f-86c573e3a5c3/iso-6624-2-2003>



PDF disclaimer

This PDF file may contain embedded typefaces. In accordance with Adobe's licensing policy, this file may be printed or viewed but shall not be edited unless the typefaces which are embedded are licensed to and installed on the computer performing the editing. In downloading this file, parties accept therein the responsibility of not infringing Adobe's licensing policy. The ISO Central Secretariat accepts no liability in this area.

Adobe is a trademark of Adobe Systems Incorporated.

Details of the software products used to create this PDF file can be found in the General Info relative to the file; the PDF-creation parameters were optimized for printing. Every care has been taken to ensure that the file is suitable for use by ISO member bodies. In the unlikely event that a problem relating to it is found, please inform the Central Secretariat at the address given below.

iTeh STANDARD PREVIEW
(standards.iteh.ai)

ISO 6624-2:2003

<https://standards.iteh.ai/catalog/standards/sist/7d34df60-6a47-4fa7-b44f-86c573e3a5c3/iso-6624-2-2003>

© ISO 2003

All rights reserved. Unless otherwise specified, no part of this publication may be reproduced or utilized in any form or by any means, electronic or mechanical, including photocopying and microfilm, without permission in writing from either ISO at the address below or ISO's member body in the country of the requester.

ISO copyright office
Case postale 56 • CH-1211 Geneva 20
Tel. + 41 22 749 01 11
Fax + 41 22 749 09 47
E-mail copyright@iso.org
Web www.iso.org

Published in Switzerland

Contents

Page

Foreword	iv
Introduction	v
1 Scope	1
2 Normative references	1
3 Overview	1
4 Ring types and designation examples	1
4.1 Type HK — Straight faced half keystone ring 7°	1
4.2 Type HKB — Barrel faced half keystone ring 7°	2
5 Common features	4
5.1 Type HK and HKB — Half keystone ring	4
5.2 Chamfered edges — Type HK and HKB rings — Outside and/or inside chamfered edges (KA, KI)	6
5.3 Type HK and HKB rings (fully faced, semi-inlaid) — Plating/coating thickness	6
6 Force factors	7
7 Dimensions	7
Bibliography	16

<https://standards.itech.ai/catalog/standards/sist/7d34df60-6a47-4fa7-b44f-86c573e3a5c3/iso-6624-2-2003>
 iTeh STANDARD PREVIEW
 (standards.itech.ai)

Foreword

ISO (the International Organization for Standardization) is a worldwide federation of national standards bodies (ISO member bodies). The work of preparing International Standards is normally carried out through ISO technical committees. Each member body interested in a subject for which a technical committee has been established has the right to be represented on that committee. International organizations, governmental and non-governmental, in liaison with ISO, also take part in the work. ISO collaborates closely with the International Electrotechnical Commission (IEC) on all matters of electrotechnical standardization.

International Standards are drafted in accordance with the rules given in the ISO/IEC Directives, Part 2.

The main task of technical committees is to prepare International Standards. Draft International Standards adopted by the technical committees are circulated to the member bodies for voting. Publication as an International Standard requires approval by at least 75 % of the member bodies casting a vote.

Attention is drawn to the possibility that some of the elements of this document may be the subject of patent rights. ISO shall not be held responsible for identifying any or all such patent rights.

ISO 6624-2 was prepared by Technical Committee ISO/TC 22, *Road vehicles*.

This first edition of ISO 6624-2 cancels and replaces ISO/TR 6624-2:1988, which has been technically revised.

ISO 6624 consists of the following parts, under the general title *Internal combustion engines — Piston rings*:

- *Part 1: Keystone rings made of cast iron* [ISO 6624-2:2003](https://standards.iteh.ai/catalog/standards/sist/7d34df60-6a47-4fa7-b44f-86c573e3a5c3/iso-6624-2-2003)
- *Part 2: Half keystone rings made of cast iron* <https://standards.iteh.ai/catalog/standards/sist/7d34df60-6a47-4fa7-b44f-86c573e3a5c3/iso-6624-2-2003>
- *Part 3: Keystone rings made of steel*
- *Part 4: Half keystone rings made of steel*

Introduction

ISO 6624 is one of a number of series of International Standards dealing with piston rings for reciprocating internal combustion engines. Others are ISO 6621^{[2], [3], [4], [5]}, ISO 6622^{[6], [7]}, ISO 6623^[8], ISO 6625^[9], ISO 6626^{[10], [11]} and ISO 6627^[12].

The common features and dimensional tables presented in this part of ISO 6624 constitute a broad range of variables and, in selecting a particular ring type, the designer must bear in mind the conditions under which it will be required to operate.

It is also essential that the designer refer to the specifications and requirements of ISO 6621-3^[4] and ISO 6621-4 before completing selection.

iTeh STANDARD PREVIEW (standards.iteh.ai)

[ISO 6624-2:2003](https://standards.iteh.ai/catalog/standards/sist/7d34df60-6a47-4fa7-b44f-86c573e3a5c3/iso-6624-2-2003)

<https://standards.iteh.ai/catalog/standards/sist/7d34df60-6a47-4fa7-b44f-86c573e3a5c3/iso-6624-2-2003>

iTeh STANDARD PREVIEW
(standards.iteh.ai)

ISO 6624-2:2003

<https://standards.iteh.ai/catalog/standards/sist/7d34df60-6a47-4fa7-b44f-86c573e3a5c3/iso-6624-2-2003>

Internal combustion engines — Piston rings —

Part 2: Half keystone rings made of cast iron

1 Scope

This part of ISO 6624 specifies the essential dimensional features of half keystone rings made of cast iron, types HK and HKB, having diameters of from 38 mm up to and including 160 mm, used in reciprocating internal combustion piston engines.

2 Normative references

The following referenced documents are indispensable for the application of this document. For dated references, only the edition cited applies. For undated references, the latest edition of the referenced document (including any amendments) applies.

ISO 6621-4, *Internal combustion engines — Piston rings — Part 4: General specifications*
<https://standards.iteh.ai/catalog/standards/sist/7d34df60-6a47-4fa7-b44f-86c573e3a5c3/iso-6624-2-2003>

3 Overview

The half keystone ring types are specified in Table 1 and Figures 1 and 2. Their common features and the dimensions of those features are specified in Tables 2 and 3 and Figures 3 to 8. Tables 4 and 5 give the force factors for the different ring types, while Table 6 gives the dimensions and forces of half keystone rings.

4 Ring types and designation examples

NOTE For the angle of half keystone rings, the same definition and measurement apply as for keystone rings (see ISO 6621-2).

4.1 Type HK — Straight faced half keystone ring 7°

4.1.1 General features

See Table 6 for dimensions and forces.

h_3 values are calculated based on $h_1 + 0,05$ mm.

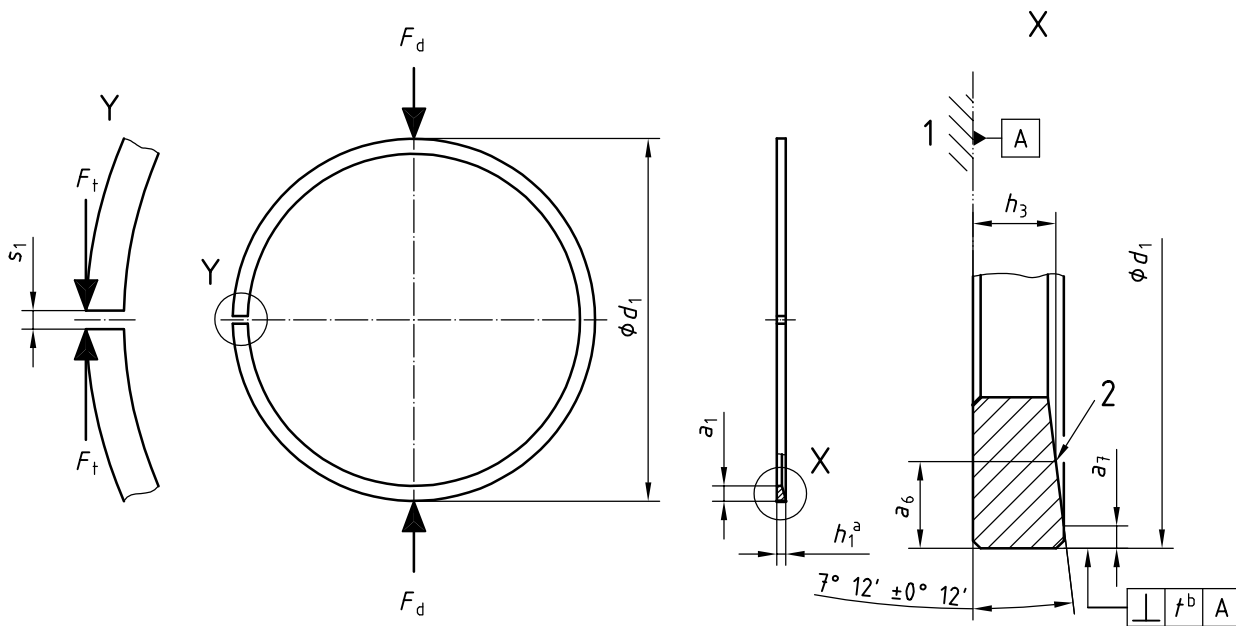

- Key**
- 1 reference plane
 - 2 mark
 - a Nominal.
 - b $t = 0,006 \times h_1$.

iTeh STANDARD PREVIEW
(standards.iteh.ai)

Figure 1 — Type HK

<https://standards.iteh.ai/catalog/standards/sist/7d34df60-6a47-4fa7-b44f-86c573e3a5c3/iso-6624-2-2003>

4.1.2 Designation

EXAMPLE Designation of a piston ring complying with the requirements of ISO 6624-2, being a 7° half keystone ring made of cast iron, with a straight faced peripheral surface (HK), of $d_1 = 90$ mm (90), of nominal ring width $h_1 = 1,5$ mm (1,5), made of heat treated martensitic spheroidal graphite cast iron, subclass 53 (MC53), and having a chromium plated peripheral surface with a minimum thickness 0,1 mm (CR2):

Piston ring ISO 6624-2 HK - 90 × 1,5 - MC53/CR2

4.2 Type HKB — Barrel faced half keystone ring 7°

4.2.1 General features

See Table 6 for dimensions and forces.

h_3 values are calculated based on $h_1 + 0,05$ mm.

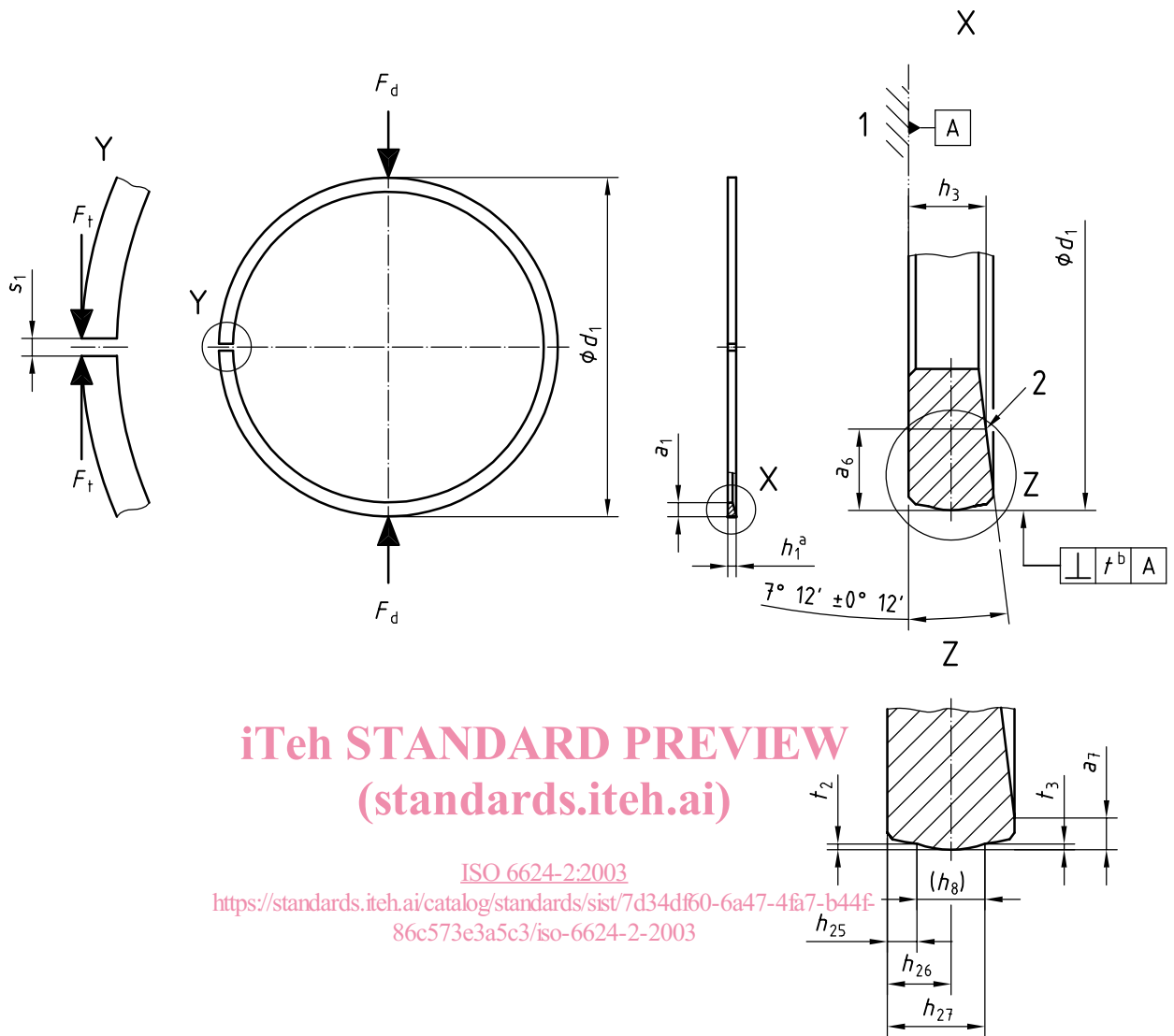

Key

1 reference plane

2 mark

a Nominal.

b $t = 0,006 \times h_1$.

Figure 2 — Type HKB

Table 1 — Gauge width (h_8) and barrel dimensions for symmetrical barrel faced compression rings

Dimensions in millimetres

h_1	h_{25}	h_{26}	h_{26} tol.	h_{27}	t_2, t_3	h_8^a
1,0	0,25	0,50	$\pm 0,15$	0,75	0,003...0,012	0,50
1,2	0,30	0,60	$\pm 0,20$	0,90		0,60
1,5	0,35	0,75	$\pm 0,25$	1,15	0,003...0,015	0,80
1,75	0,35	0,85	$\pm 0,30$	1,35		1,00
2,0	0,40	1,00	$\pm 0,30$	1,60		1,20
2,5	0,45	1,25	$\pm 0,40$	2,05		1,60
3,0	0,50	1,50	$\pm 0,50$	2,50	0,005...0,020	2,00
3,5	0,55	1,75	$\pm 0,50$	2,95		2,40

^a Gauge width (h_8) only informative; may be used only if agreed between manufacturer and client.

4.2.2 Designation

EXAMPLE Designation of a piston ring complying with the requirements of ISO 6624-2, being a 7° half keystone ring made of cast iron, with a barrel faced peripheral surface (HKB), of $d_1 = 90$ mm (90), of nominal ring width $h_1 = 1,5$ mm (1,5), made of non-heat-treated grey cast iron, subclass 12 (MC12), and having a chromium plated peripheral surface with a minimum thickness of 0,1 mm (CR2):

Piston ring ISO 6624-2 HKB - 90 x 1,5 - MC12/CR2

ISO 6624-2:2003

<https://standards.iteh.ai/catalog/standards/sist/7d34df60-6a47-4fa7-b44f-86c573e3a5c3/iso-6624-2-2003>

5 Common features

5.1 Type HK and HKB — Half keystone ring

5.1.1 Uncoated rings



Key

1 mark

Figure 3 — Uncoated rings

5.1.2 Chromium plated or spray coated rings

5.1.2.1 Fully faced



Key

1 mark

Figure 4 — Fully faced rings

5.1.2.2 Semi-inlaid



Key

1 mark

ISO 6624-2:2003
<https://standards.iteh.ai/catalog/standards/sist/7d34df60-6a47-4fa7-b44f-86c573e3a5c3/iso-6624-2-2003>

Figure 5 — Semi-inlaid rings

5.1.2.3 Inlaid (not recommended for chromium plated rings)



Key

1 mark

Figure 6 — Inlaid rings