



Designation: D 4729 – 04

## Standard Test Method for In Situ Stress and Modulus of Deformation Using the Flatjack Method<sup>1</sup>

This standard is issued under the fixed designation D 4729; the number immediately following the designation indicates the year of original adoption or, in the case of revision, the year of last revision. A number in parentheses indicates the year of last reapproval. A superscript epsilon ( $\epsilon$ ) indicates an editorial change since the last revision or reapproval.

### 1. Scope\*

1.1 The flatjack test measures stress at a rock surface. The modulus of deformation and the long-term deformational properties (creep) may also be evaluated.

1.2 All observed and calculated values shall conform to the guidelines for significant digits and rounding established in Practice D 6026.

1.2.1 The method used to specify how data are collected, calculated, or recorded in this standard is not directly related to the accuracy to which the data can be applied in design or other uses, or both. How one applies the results obtained using this standard is beyond its scope.

1.3 *Limitation*—The flatjack test measures the average stress normal to the surface of the test chamber. Undisturbed stress levels must be determined by theoretical interpretations of these data.

#### 1.4 *Assumptions and Factors Influencing the Data:*

1.4.1 The stress relief is assumed to be an elastic, reversible process. In nonhomogeneous or highly fractured materials, this may not be completely true.

1.4.2 The equations assume that the rock mass is isotropic and homogeneous. Anisotropic effects may be estimated by testing in different orientations.

1.4.3 The flatjack is assumed to be 100 % efficient. The design and size requirements of 7.1 were determined to satisfy this requirement to within a few percent.

1.4.4 The jack is assumed to be aligned with the principal stresses on the surface of the opening. Shear stresses are not canceled by jack pressure. Orientating the tests in three directions in each plane tested prevents the misalignment from being excessive for at least one of the tests.

1.5 The values stated in inch-pound units are to be regarded as the standard.

1.6 *This standard does not purport to address all of the safety concerns, if any, associated with its use. It is the responsibility of the user of this standard to establish appropriate safety and health practices and determine the applicability of regulatory requirements prior to use.*

### 2. Referenced Documents

#### 2.1 *ASTM Standards:*<sup>2</sup>

D 653 Terminology Relating to Soil, Rock and Contained Fluids

D 2113 Practice for Diamond Core Drilling for Site Investigation

D 3740 Practice for Minimum Requirements for Agencies Engaged in the Testing and/or Inspection of Soil and Rock as Used in Engineering Design and Construction

D 5720 Practice of Electronic Transducer-based Pressure Measurement Systems for Geotechnical Purposes

D 6026 Practice for Using Significant Digits in Geotechnical Data

D 6027 Practice for Calibrating Linear Displacement Transducers for Geotechnical Purposes

### 3. Terminology

3.1 For terminology used in this test method, refer to Terminology D 653.

#### 3.2 *Definitions of Terms Specific to This Standard:*

3.2.1 *cancellation pressure*—the pressure in the flatjack required to return the rock to its initial position.

3.2.2 *skin stress*—the tangential stress at the surface of an opening.

3.2.3 *undisturbed stress*—the stress field existing in a rock mass prior to excavation of an opening.

### 4. Summary of Test Method

4.1 The in situ stress in the rock mass is relieved by cutting a slot into the rock perpendicular to the surface of the test adit. The deformation caused by this stress relief is measured. A hydraulic flatjack is placed into the slot and is pressurized until the above-measured displacement is canceled. This reapplied stress is approximately equal to the stress in the rock mass at the test location in a direction perpendicular to the plane of the jack. The deformational characteristics of the rock mass are evaluated by incrementally loading the flatjack and measuring the deformation.

<sup>1</sup> This test method is under the jurisdiction of ASTM Committee D18 on Soil and Rock and is the direct responsibility of Subcommittee D18.12 on Rock Mechanics. Current edition approved Nov. 1, 2004. Published December 2004. Originally approved in 1987. Last previous edition approved in 1997 as D 4729 – 87 (1997).

<sup>2</sup> For referenced ASTM standards, visit the ASTM website, www.astm.org, or contact ASTM Customer Service at service@astm.org. For *Annual Book of ASTM Standards* volume information, refer to the standard's Document Summary page on the ASTM website.

\*A Summary of Changes section appears at the end of this standard.

## 5. Significance and Use

5.1 *Tests in Orthogonal Directions*—The flatjack most accurately determines the stress parallel to the long axis of the adit, because this stress is the least affected by the presence of the opening. (The other tangential stress is highly concentrated.) In addition, if the adit is in a stress field where one of the stresses is significantly larger than the others (3 or 4 times), certain locations in the adit may be in very low compressive or even tensile stress. Flatjack tests in these locations can give anomalous and misleading results. Because of these factors, the test adit should have at least two, and preferably three, long (at least 4 to 5 times the diameter), straight sections at about 90° to each other. Testing should be distributed evenly in all three sections to provide redundant data and, if results in one section are anomalous, to allow the program to produce sufficient usable data.

NOTE 1—Not withstanding the statements on precision and bias contained in this test method; the precision of this test method is dependent on the competence of the personnel performing it, and the suitability of the equipment and facilities used. Agencies that meet the criteria of Practice D 3740 are generally considered capable of competent and objective testing. Users of this test method are cautioned that compliance with Practice D 3740 does not in itself assure reliable testing. Reliable testing depends on many factors; Practice D 3740 provides a means of evaluating some of those factors.

## 6. Interferences

### 6.1 Personnel Prequalification:

6.1.1 *Test Personnel*—All personnel involved in performing the test, including the technicians and test supervisor, shall be formally prequalified.

6.1.2 *Drilling and Sawcut Personnel*—Quality drilling and sawcutting is important to achievement of successful flatjack tests. The drilling and sawcut personnel should be capable of performing the precision necessary to successfully produce the slot and instrument holes.

6.2 *Equipment Performance Verification*—The compliance of all equipment and apparatus with performance specifications apparatus shall be verified. If no requirements are stated, the manufacturer's specifications for the equipment shall be the required level of performance. Performance verification is generally done by calibrating the equipment and measurement systems. Calibration and documentation shall be accomplished according to standard procedures such as in Practices D 5720 and D 6027.

6.3 *Local Geologic Features*—Local features, particularly faults, shear zones, etc., can influence the local stress field. Large inclusions in the rock can affect both the stress and deformational properties. Test locations should be carefully selected so that the effects of such features are minimized or, if they are the features of interest, accounted for fully.

6.4 *Influence of Excavations*—Other excavations intersecting the test adit will cause complex stress concentration effects by superposition. Flatjack tests should be located at least three diameters of the intersecting feature away from that feature. If the test adit is excavated by conventional methods, then the surfaces for testing should be further excavated by nonblasting techniques to remove loose material resulting from stress relief or blasting.

## 7. Apparatus

7.1 *Flatjacks*—Flatjacks shall be designed to operate at pressures of several thousand pounds per square inch when properly installed. The jacks shall be constructed so that the two main plates move apart in essentially a parallel manner over the range of the jack. The range shall be at least 0.25 in. (6 mm). The jacks covered by this standard are square and the area of the jack shall be no less than 2 ft (0.6 m) wide.

NOTE 2—Other flat jack shapes are available that may be better suited for specific applications. This standard only covers the basic square flat jack, however the basic principles discussed here will still apply.

### 7.2 Instrumentation:

7.2.1 *Pressure*—Electronic transducers or hydraulic gages may be used to monitor flatjack pressure. The pressure transducer shall have an accuracy of at least  $\pm 20$  lbf/in.<sup>2</sup> ( $\pm 0.14$  MPa), including errors introduced by the readout system and a sensitivity of at least 10 lbf/in.<sup>2</sup> (0.069 MPa).

7.2.2 *Deformation*—Deformation measurement devices including mechanical dial gages, and electronic transducers such as LVDTs or linear potentiometers. The devices can be either stationary, or portable depending on the site requirements. The deformation device shall have an accuracy of at least  $\pm 0.0001$  in. ( $\pm 0.0025$  mm) and a sensitivity of at least 0.00005 in. (0.0013 mm).

7.2.3 *Internal Gages*—Strain gages inside the flatjack shall be calibrated prior to installation in the jack. The effects of the hydraulic oil and ambient pressure increase on the gages shall be determined prior to testing.

7.3 *Mortar*—If mortar is used to cement the flatjack into the slot, a high-early strength, non-shrink material shall be used. The mortar may include up to 50 % clean sand by weight, with grain size between 20- and 60-mesh. Clean, potable water shall be used for the mortar. The cured mortar shall have a strength greater than the stress applied by the flatjack. The modulus of the mortar may be required to be removed from some of the determinations of rock modulus.

7.4 *Sawing Equipment*—Equipment used to saw a slot in the rock should be of a type where large center or end holes are not required. These large holes can cause serious changes in the stress field to be measured.

## 8. Procedure

8.1 *Groups at Each Test Station*—At least one group of jacks should be tested in each adit section. Each group should have three flatjacks installed horizontally inclined 45° and vertically. The jacks in each group should all be placed in one part of the adit within 20 ft (6.1 m) of each other along the length of the adit.

### 8.2 Surface Preparation:

8.2.1 *Rock Quality*—The flatjack and deformation instrumentation should not be installed in loose, broken, or drummy material. Loose, broken, or drummy material may be detected by a dull, hollow sound when struck with a hammer; such material should be removed.

8.2.2 *Dimensions*—The prepared surface shall extend at least 1 ft (0.30 m) past either end of the flatjack slot and at least

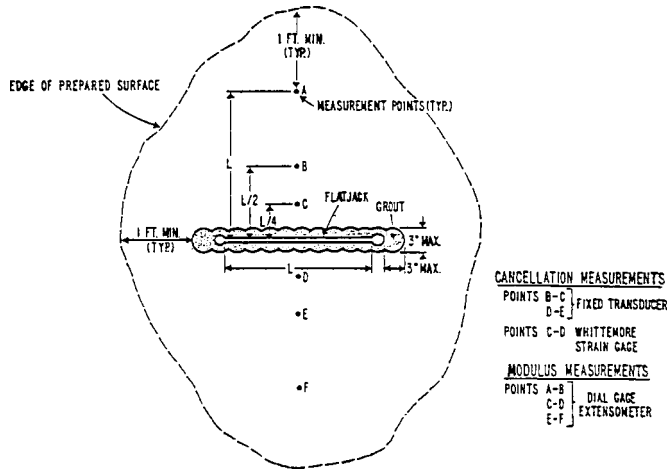

**FIG. 1 Recommended Flatjack Measurement Array, Surface Measurements**

1 ft (0.30 m) past the furthest measuring points. The transducers or flatjack shall be 1 ft (0.30 m) inside the prepared surface at any point (see Fig. 1).

**8.2.3 Method**—Drilling to a uniform depth may be required to prepare the rock face. Residual rock between the drill holes may be removed by moving the bit back and forth until a smooth surface is achieved. Alternatively, in hard, competent rock, controlled blasting with very small charges may be used to remove the residual rock. In softer material, coarse grinding, chipping, or cutting devices may be required.

**8.2.4 Smoothness**—Ideally, the prepared surface shall be a plane. The difference between the highest and lowest points on the prepared surface shall be not greater than 2 in. (50 mm).

**8.3 Transducer and Measurement Points Installation**—Transducers and measurement points shall be installed on the centerline normal to the flatjack, either at the surface or at depth as shown in Fig. 1. Transducers for stress determination shall be installed within  $L/2$  of the flatjack slot, where  $L$  is the width of the flatjack.

**8.4 Slot Cutting**—The slot can be formed by sawing or by drilling overlapping holes in weak or highly fractured material. Vibration should be minimized. The slot shall be no more than 3 in. (74 mm) wide, and extend no more than 3 in. (75 mm) past the edges of the flatjack. It shall be deep enough that the flatjack may be inserted 3 in. (75 mm) beyond the lowest point on the rock fact adjacent to the slot. If drilled, care shall be taken that the holes are straight and parallel to keep the bottom of the slot open to receive the jack. The slot shall be washed clean of all dirt and cuttings, using clean water.

**8.5 Relaxation Measurements**—Deformation shall be measured immediately upon completion of slot cutting and again immediately prior to testing. If the rock undergoes strain under constant load over a period of time, several intermediate readings shall be taken to evaluate this effect.

**8.6 Flatjack Installation**—Flatjacks shall be centered in the slot and recessed 3 in. (75 mm) from the face of the excavation to minimize the possibility of rupture during pressurization. The mortar, if used, should surround the jack and shall be free from voids. The jack shall be installed to allow sufficient time

**In Situ Stress and Modulus of Deformation Determination Using the Flatjack Method**

**Test Data Sheet**

Project \_\_\_\_\_ Test No. \_\_\_\_\_  
 Feature \_\_\_\_\_ Test location \_\_\_\_\_  
 Rock type \_\_\_\_\_ Orientation \_\_\_\_\_

Equipment Description	Serial No.	Date of next calibration

Sketch of flatjack, geology, and measurement geometry:

**FIG. 2 Flat Jack Test Site Description Data Sheet**

for the mortar to attain compressive strength greater than maximum anticipated jack stress.

**8.7 Flatjack Testing**—The flatjack pressure shall be raised in 100 lb/in.<sup>2</sup> (0.7 MPa) increments until cancellation of all measuring points has been achieved. Deformation shall be read after each pressure increment. The peak pressure shall be maintained for 15 min to check for time-dependent deformation; deformation readings shall be taken every 5 min. The pressure shall be reduced in 100 lb/in.<sup>2</sup> (0.69 MPa) decrements to zero, with deformation read after every decrement. Zero pressure shall be maintained for 15 min to check for time-dependent deformation; deformation readings shall be taken every 5 min. The cycle shall be repeated at least two more times using equal pressure increments and decrements. The peak jack stress of these cycles should be as high as possible and be determined by the test engineer in the field depending on the jack and rock strength and the cancellation pressure.

**8.8 Data Recording Requirements**—Examples of test data sheets and the type of data to record are shown on Figs. 2 and 3. However, the data requirements may be site specific and shall be developed using the minimum requirements specified in Section 10, Reports.

**9. Calculation**

**9.1 General**—The calculation of stress and modulus of deformation from flatjack data is influenced by the complex loading geometry of the test. In addition, the load applied by the flatjack is not the same as the load originally acting on the rock. The jack expands in one direction only, so lateral and shear components are not restored. This is particularly significant when the jack is not aligned with a principal stress. Several elastic models and assumptions have been used to compensate for these factors, leading to varied and sometimes contradictory methods of data reduction. The equations presented here are among those more widely accepted and have been found to produce results comparable with those of other