

---

---

**Conveyor belts — Transverse flexibility  
(troughability) — Test method**

*Courroies transporteuses — Flexibilité transversale (aptitude à la mise en auge) — Méthode d'essai*

**iTeh STANDARD PREVIEW**  
**(standards.iteh.ai)**

[ISO 703:2007](https://standards.iteh.ai/catalog/standards/sist/07d54bac-5d1e-4b10-9fbf-46446ae85df4/iso-703-2007)

<https://standards.iteh.ai/catalog/standards/sist/07d54bac-5d1e-4b10-9fbf-46446ae85df4/iso-703-2007>



**PDF disclaimer**

This PDF file may contain embedded typefaces. In accordance with Adobe's licensing policy, this file may be printed or viewed but shall not be edited unless the typefaces which are embedded are licensed to and installed on the computer performing the editing. In downloading this file, parties accept therein the responsibility of not infringing Adobe's licensing policy. The ISO Central Secretariat accepts no liability in this area.

Adobe is a trademark of Adobe Systems Incorporated.

Details of the software products used to create this PDF file can be found in the General Info relative to the file; the PDF-creation parameters were optimized for printing. Every care has been taken to ensure that the file is suitable for use by ISO member bodies. In the unlikely event that a problem relating to it is found, please inform the Central Secretariat at the address given below.

**iTeh STANDARD PREVIEW**  
**(standards.iteh.ai)**

ISO 703:2007

<https://standards.iteh.ai/catalog/standards/sist/07d54bac-5d1e-4b10-9fbf-46446ae85df4/iso-703-2007>



**COPYRIGHT PROTECTED DOCUMENT**

© ISO 2007

All rights reserved. Unless otherwise specified, no part of this publication may be reproduced or utilized in any form or by any means, electronic or mechanical, including photocopying and microfilm, without permission in writing from either ISO at the address below or ISO's member body in the country of the requester.

ISO copyright office  
Case postale 56 • CH-1211 Geneva 20  
Tel. + 41 22 749 01 11  
Fax + 41 22 749 09 47  
E-mail [copyright@iso.org](mailto:copyright@iso.org)  
Web [www.iso.org](http://www.iso.org)

Published in Switzerland

## Foreword

ISO (the International Organization for Standardization) is a worldwide federation of national standards bodies (ISO member bodies). The work of preparing International Standards is normally carried out through ISO technical committees. Each member body interested in a subject for which a technical committee has been established has the right to be represented on that committee. International organizations, governmental and non-governmental, in liaison with ISO, also take part in the work. ISO collaborates closely with the International Electrotechnical Commission (IEC) on all matters of electrotechnical standardization.

International Standards are drafted in accordance with the rules given in the ISO/IEC Directives, Part 2.

The main task of technical committees is to prepare International Standards. Draft International Standards adopted by the technical committees are circulated to the member bodies for voting. Publication as an International Standard requires approval by at least 75 % of the member bodies casting a vote.

Attention is drawn to the possibility that some of the elements of this document may be the subject of patent rights. ISO shall not be held responsible for identifying any or all such patent rights.

ISO 703 was prepared by Technical Committee ISO/TC 41, *Pulleys and belts (including veebelts)*, Subcommittee SC 3, *Conveyor belts*.

This third edition of ISO 703 cancels and replaces ISO 703-1:1999, of which it constitutes a technical revision. It also incorporates the Technical Corrigendum, ISO 703-1:1999/Cor. 1:2006.

ISO 703:2007

<https://standards.iteh.ai/catalog/standards/sist/07d54bac-5d1e-4b10-9fbf-46446ae85df4/iso-703-2007>

## Introduction

A large number of conveyor belts work in the shape of a trough. If a conveyor belt is too stiff transversely it does not rest on the central idler roller when unloaded. Its balance is then unstable and it is subject to lateral travel, which may cause its destruction.

It is possible to make a section of the conveyor belt take on the shape of a trough under its own mass, by suspending the section by its edges. However, this does not necessarily indicate what happens when the conveyor belt is not carrying a load.

The results obtained from the test method specified in this International Standard will, however, allow an assessment to be made as to whether the troughing characteristics of the conveyor belt are suitable for the intended application.

## iTeh STANDARD PREVIEW (standards.iteh.ai)

ISO 703:2007

<https://standards.iteh.ai/catalog/standards/sist/07d54bac-5d1e-4b10-9fbf-46446ae85df4/iso-703-2007>

# Conveyor belts — Transverse flexibility (troughability) — Test method

## 1 Scope

This International Standard specifies a test method for determining the transverse flexibility (troughability) of a conveyor belt, expressed as a ratio,  $F/L$ . The method is not suitable or valid for light conveyor belts as described in ISO 21183-1<sup>[1]</sup>.

NOTE The transverse “flexibility” determined by the method described in this International Standard is only indirectly associated with the inverse of flexural modulus as specified in ISO 178<sup>[2]</sup>. Nor does it take into consideration the differences in “flexibility” as exhibited by three-point and four-point bending, which takes account of the flexural strain and the thickness of the test piece.

## 2 Normative references

The following referenced documents are indispensable for the application of this document. For dated references, only the edition cited applies. For undated references, the latest edition of the referenced document (including any amendments) applies.

ISO 583<sup>1)</sup>, *Conveyor belts with a textile carcass — Total belt thickness and thickness of constitutive elements — Test methods*

ISO 18573, *Conveyor belts — Test atmospheres and conditioning periods*

## 3 Symbols

- $F$  vertical deflection in test piece corrected for belt thickness, in millimetres
- $F_1$  vertical deflection in test piece, in millimetres (see Figures 1 and 2)
- $L$  length of test piece when laid flat, in millimetres (equivalent to full width of installed conveyor belt)
- $d$  thickness of the test piece, in millimetres (see Figure 2).

## 4 Principle

A test piece, consisting of a transverse section of belt of length  $L$ , is suspended at both ends with the carrying face uppermost, so that the upper edges of these ends are in the same horizontal plane.

The transverse flexibility (troughability) is determined by measuring the maximum deflection,  $F$ , of the test piece under its own weight. It is expressed as the ratio,  $F/L$ .

---

1) To be published. (Revision of ISO 583-1:1999)

**5 Apparatus** (see Figure 1)

**5.1 Two rigid horizontal bars**, conveniently supported. The unsupported length of the bars shall be greater than the test length ( $L$ ).

**5.2 Two clamps**, to be attached to the ends of the test piece, with suspension lugs for attachment to the suspending wires. The construction of the clamps shall allow for a rigid bar or straightedge to be placed in contact with the belt, as shown in Figure 2, to establish the datum line necessary for measuring the deflection. The clamps shall be sufficiently wide and rigid to maintain the width of the test pieces free from curvature, and shall exert no bending moment which might influence the deflection of the test piece.

**5.3 Four steel suspension wires**, of equal length, each with adjustable stirrups on both ends for attachment to the horizontal bars and clamps. The attachments to the horizontal bars and clamps should not impede the free movement of the adjustable stirrups when maintaining the suspension wires in the vertical during the test.

**5.4 Means of measuring the deflection,  $F_1$** , to the nearest millimetre (see Figure 2).

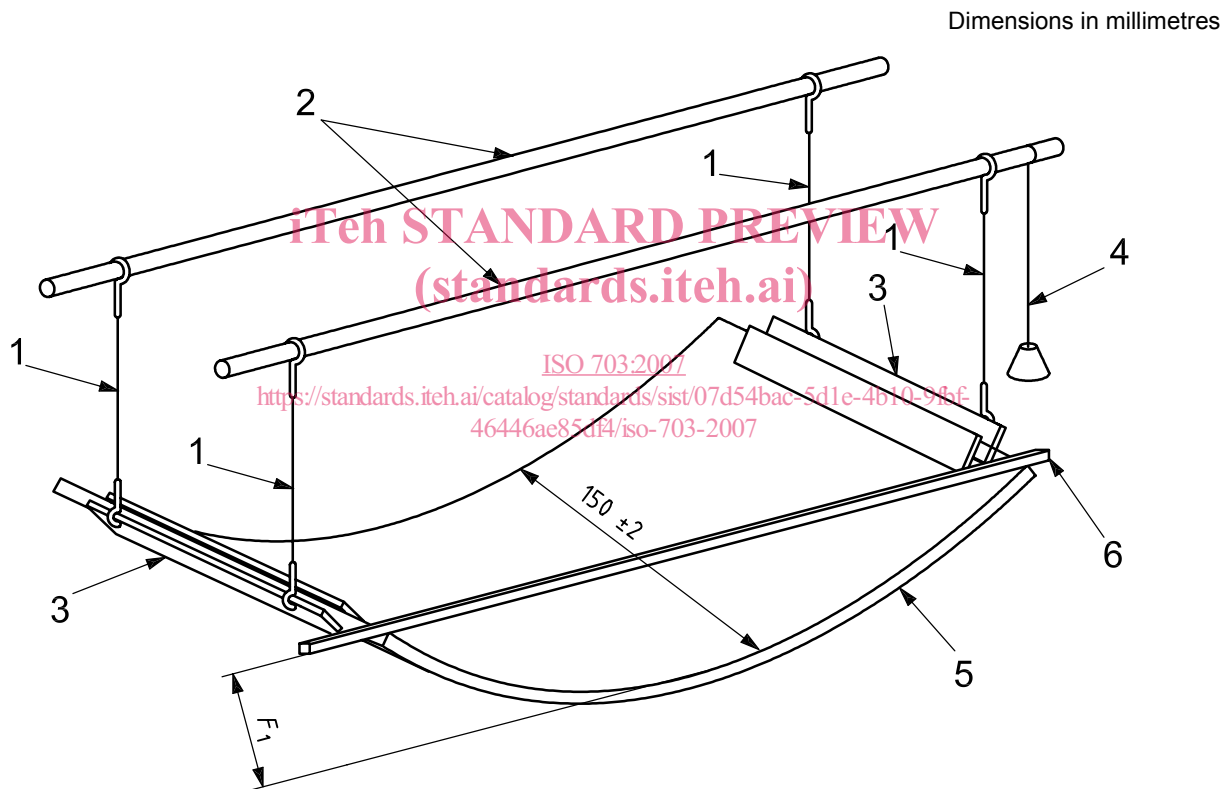

**Key**

- 1 four steel suspension wires
- 2 two rigid horizontal bars
- 3 two clamps
- 4 plumb line
- 5 test piece
- 6 rigid bar to establish datum line

**Figure 1 — Typical apparatus for measuring transverse flexibility (troughability)**

## 6 Test piece

### 6.1 Dimensions

The test piece shall conform to the following requirements:

- a) its form shall be a rectangular parallelepiped;
- b) its length ( $L$ ) shall be the overall width of the installed conveyor belt, when laid flat;
- c) its width, in the longitudinal direction of the belt, shall be  $(150 \pm 2)$  mm;
- d) its thickness ( $d$ ) shall be the overall thickness of the conveyor belt, including covers as determined in accordance with ISO 583.

### 6.2 Conditioning

Condition the test pieces in accordance with ISO 18573, using atmosphere A, B or C, and then carry out the tests immediately after completion of the conditioning period.

## 7 Procedure

Immediately before the test, ensure that the clamps are free to swivel and do not exert a bending force on the test piece.

Measure the flat length ( $L$ ) of the test piece in millimetres.

Measure the thickness ( $d$ ) of the test piece, in millimetres, in accordance with ISO 583.

Fit the test piece, carrying face uppermost, while in the flat position, into the suspended clamps.

Allow the test piece to fall under its own weight from the flat position into the troughed position.

Adjust the apparatus so that the suspending forces act vertically throughout the test period.

After 5 min, measure the vertical deflection,  $F_1$ , of the test piece (see Figure 2) and add to this measurement the dimension  $0,5d$  to give the value for  $F$ .

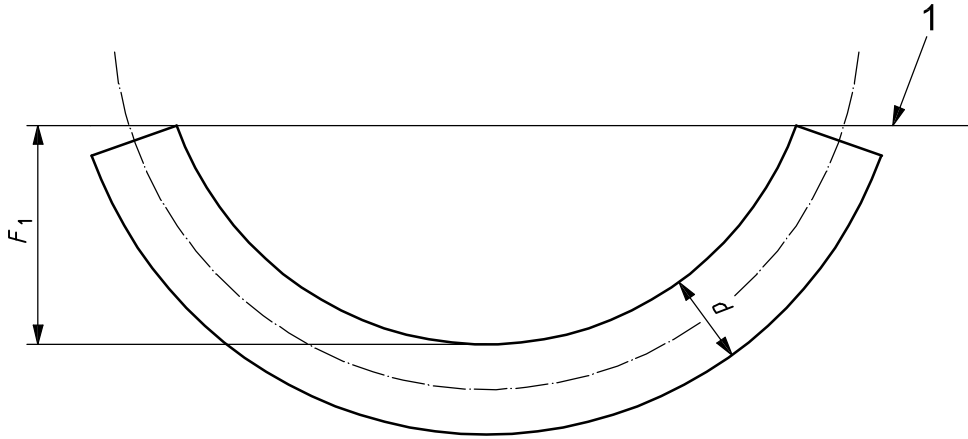

**Key**

- $d$  thickness of test piece
- $F_1$  vertical deflection
- 1 datum line

**Figure 2 — Determination of deflection,  $F_1$**

**8 Calculation and expression of results**

iTech STANDARD PREVIEW  
(standards.iteh.ai)

Calculate the value of  $F$  from the following equation:

$$F = F_1 + 0,5d$$

ISO 703:2007

[https://standards.iteh.ai/catalog/standards/sist/07d54bac-5d1e-4b10-9fbf-](https://standards.iteh.ai/catalog/standards/sist/07d54bac-5d1e-4b10-9fbf-46446ae85471/iso-703-2007)

Express the results of the measurements in the form of  $F/L$ .

**9 Test report**

The test report shall contain the following information:

- a) reference to this International Standard (i.e. ISO 703);
- b) identification of the conveyor belt tested;
- c) the test length ( $L$ ) (see Clause 3);
- d) the thickness of the test piece ( $d$ ) (see 6.1);
- e) the conditioning atmosphere used (A, B or C);
- f) the value of ratio  $F/L$ ;
- g) the date of the test.



## Bibliography

- [1] ISO 21183-1, *Light conveyor belts — Part 1: Principal characteristics and applications*
- [2] ISO 178, *Plastics — Determination of flexural properties*

**iTeh STANDARD PREVIEW**  
**(standards.iteh.ai)**

[ISO 703:2007](https://standards.iteh.ai/catalog/standards/sist/07d54bac-5d1e-4b10-9fbf-46446ae85df4/iso-703-2007)

<https://standards.iteh.ai/catalog/standards/sist/07d54bac-5d1e-4b10-9fbf-46446ae85df4/iso-703-2007>