



Designation: D6420 – 99 (Reapproved 2004)

# Standard Test Method for Determination of Gaseous Organic Compounds by Direct Interface Gas Chromatography-Mass Spectrometry<sup>1</sup>

This standard is issued under the fixed designation D6420; the number immediately following the designation indicates the year of original adoption or, in the case of revision, the year of last revision. A number in parentheses indicates the year of last reapproval. A superscript epsilon ( $\epsilon$ ) indicates an editorial change since the last revision or reapproval.

## 1. Scope

1.1 This test method employs a direct interface gas chromatograph/mass spectrometer (GCMS) to identify and quantify the 36 volatile organic compounds (or sub-set of these compounds) listed as follows. The individual Chemical Abstract Service (CAS) numbers are listed after each compound.

Benzene-71432	Methylene chloride-75092
Bromodichloromethane-75274	1,1,2,2-Tetrachloroethane-79349
Carbon disulfide-75150	1,1,1-Trichloroethane-71556
Chloroform-67663	1,1,2-Trichloroethane-79005
Methyl iso-Butyl ketone-108101	p-Xylene-106423
Styrene-100425	Bromomethane-74839
Tetrachloroethylene-127184	Carbon tetrachloride-56235
Toluene-108883	Chlorobenzene-108907
Bromoform-75252	c-1,3-Dichloropropene-10061015
Vinyl acetate-108054	1,2-Dichloroethane-156592
Vinyl chloride-75014	1,1-Dichloroethene-75354
Chloromethane-74873	t-1,2-Dichloroethene-156605
cis-1,2-Dichloroethene-156592	Methyl ethyl ketone-78933
Dibromochloromethane-124481	2-Hexanone-591786
1,1-Dichloroethane-107062	t-1,3-Dichloropropene-542756
1,2-Dichloropropane-78875	Trichloroethene-79016
Ethylbenzene-100414	m-Xylene-108383
Ethyl chloride-75003	o-Xylene-95476

1.2 The test method incorporates a performance-based approach, which validates each GCMS analysis by placing boundaries on the instrument response to gaseous internal standards and their specific mass spectral relative abundance. Using this approach, the test method may be extended to analyze other compounds.

1.3 The test method provides on-site analysis of extracted, unconditioned, and unsaturated (at the instrument) gas samples from stationary sources. Gas streams with high moisture content may require conditioning to prevent moisture condensation within the instrument. For these samples, quality assurance (QA) requirements are provided in the test method to validate the analysis of polar, water-soluble compounds.

1.4 The instrument range should be sufficient to measure the listed volatile organic compounds from 150 ppb(v) to 100

ppm(v), using a full scan operation (between 45 and 300 atomic mass units). The range may be extended to higher or lower concentrations using either of the following procedures:

1.4.1 The initial three-point calibration concentrations and the continuing calibration checks are adjusted to match the stack concentrations, or

1.4.2 The three-point calibration is extended to include additional concentrations to cover the measurement range.

1.5 The minimum quantification level is 50 % of the lowest calibration concentration. Responses below this level are considered to be estimated concentrations, unless a calibration standard check is conducted at a lower concentration to demonstrate linearity. The sensitivity of the GCMS measurement system for the individual target analytes depends upon:

1.5.1 The specific instrument response for each target analyte and the number of mass spectral quantification ions available.

1.5.2 The amount of instrument noise, and

1.5.3 The percent moisture content of the sample gas.

1.6 *This standard does not purport to address all of the safety concerns, if any, associated with its use. It is the responsibility of the user of this standard to establish appropriate safety and health practices and determine the applicability of regulatory limitations prior to use.* Additional safety precautions are described in Section 9.

## 2. Referenced Documents

2.1 *ASTM Standards*:<sup>2</sup>

[D1356 Terminology Relating to Sampling and Analysis of Atmospheres](#)

[D3195 Practice for Rotameter Calibration](#)

2.2 *EPA Test Methods*:

[Method 1—Sample and Velocity Traverses for Stationary Sources](#)<sup>3</sup>

<sup>1</sup> This test method is under the jurisdiction of ASTM Committee D22 on Sampling and Analysis of Atmospheres and is the direct responsibility of Subcommittee D22.03 on Ambient Atmospheres and Source Emissions.

Current edition approved October 1, 2004. Published December 2004. Originally approved in 1999. Last previous edition approved in 1999 as D6420 - 99. DOI: 10.1520/D6420-99R04.

<sup>2</sup> For referenced ASTM standards, visit the ASTM website, www.astm.org, or contact ASTM Customer Service at service@astm.org. For *Annual Book of ASTM Standards* volume information, refer to the standard's Document Summary page on the ASTM website.

<sup>3</sup> Code of Federal Regulations 40 CFR Part 60, Appendix A, available from Superintendent of Documents, U.S. Government Printing Office, Washington, DC 20402.

**Method 2—Determination** of Stack Gas Velocity and Volumetric Flow Rate (Type S Pitot Tube)<sup>3</sup>

**Method 3—Gas** Analysis for Carbon Dioxide, Oxygen, Excess Air, and Dry Molecular Weight<sup>3</sup>

**Method 4—Determination** of Moisture Content in Stack Gases<sup>3</sup>

**Method 624—Purgables**<sup>4</sup>

### 3. Terminology

3.1 See Terminology **D1356** for definition of terms used in this test method.

3.2 *Definitions of Terms Specific to This Standard:*

3.2.1 *blank analysis, n*—injecting zero air or nitrogen into the GCMS to determine background levels of the target analytes.

3.2.2 *CCC, n—continuing calibration check*—injecting calibration gas standards into the GCMS to verify the calibration status.

3.2.2.1 *Discussion*—The continuing calibration check is performed before each testing day, before resuming sampling after instrument shutdown or malfunction, and before resuming sampling after 12 h of continuous instrument operation.

3.2.3 *quantification ion, n*—a specific ion in the analytes mass spectrum that is used for quantification.

3.2.4 *system calibration, n*—calibration obtained by injecting the calibration standard(s) through the entire sampling system.

3.2.5 *system zero, n*—zero obtained by injecting dry nitrogen or zero gas through the entire sampling system to determine the system background levels of the target analytes.

### 4. Summary of Test Method

4.1 *Analysis*—Volatile Organic Hazardous Air Pollutants (VOHAP) are analyzed using gas chromatography (GC) to separate the individual compounds and mass spectrometry (MS) to identify the compounds. The MS scans a defined mass range (usually from 45 to 300 atomic mass units (amu) for combustion sources) to identify the specific fragments for each molecule. The target analytes are identified positively by: (1) comparing eluting analyte GC peak retention times in the total ion chromatograph (TIC) to those contained in a three-point calibration, and (2) examining the mass spectral pattern of the eluted peaks. Internal standards are used to correct for hardware-related errors such as different injection volumes, operational temperature fluctuations, and electron multiplier drift.

4.2 *Sampling*—Samples are extracted from the stack or duct at a constant rate, filtered, conditioned (if required), and transported to the GCMS for analysis. Calibration gases are introduced at the extractive probe outlet, upstream of the primary particulate filter. All sample extraction components are maintained at temperatures that prevent moisture condensation within the measurement system components.

### 5. Significance and Use

5.1 This field test method determines the mass concentration of VOHAPs (or any subset) listed in Section 1.

5.2 Multiplying the mass concentration by the effluent volumetric flow rate (see 2.2) yields mass emission rates.

5.3 This field test method employs the typical laboratory GCMS techniques and QA/QC procedures.

5.4 This field test method provides data with accuracy and precision similar to most laboratory GCMS instrumentation.

NOTE 1—Supporting data are available from ASTM Headquarters Request RR:\_\_\_\_\_.

### 6. Interferences

6.1 *Analytical Interferences*—Analytical interferences occur when chromatographic peak(s) and quantification ion(s) overlap to such an extent that quantification of specific target compounds is prohibited. The nature of the GCMS technique virtually eliminates these types of analytical interferences. However, compounds having very simple mass spectra (that is, only one or two mass fragments) may be difficult to identify positively.

6.2 *Sampling System Interferences*—Sampling system interferences occur when target analytes are not transported to the instrumentation or when compounds damage the measurement system components. Water, reactive particulate matter, adsorptive sites within the sampling system components, and reactive gases are examples of such potential sampling system interferences. Specific provisions and performance criteria are included in this test method to detect and prevent the presence of sampling system interferences.

### 7. Apparatus

7.1 *Analytical Instrumentation:*

7.1.1 *Gas Chromatograph/Mass Spectrometer (GCMS)*, capable of separating the analyte mixture and detecting compounds in the 45 to 300 atomic mass unit (amu) range.

7.1.2 *Personal Computer*, with compatible GCMS software for control of the GCMS and for data quantification.

7.2 *Sampling System:*

7.2.1 *Sampling Probe*, glass, stainless steel, or other appropriate material of sufficient length and physical integrity to sustain heating, prevent adsorption of analytes, and to reach the gas sampling point.

7.2.2 *Calibration Assembly*, typically fabricated by user, to introduce calibration standards into the sampling system at the probe outlet, upstream of the primary particulate filter, at the same pressure and temperature as that of the effluent samples, with provisions for monitoring the sample pressure and temperature during continuing calibrations and effluent sampling.

7.2.3 *Particulate Filters*, rated at 0.3  $\mu\text{m}$ , placed immediately after the heated probe and after the sample condenser system.

7.2.4 *Pump*, leak-free, with heated head, capable of maintaining an adequate sample flow rate (at least 1.5 L/min).

7.2.5 *Sampling Line*, of suitable internal diameter, heated to prevent sample condensation, made of stainless steel, tetrafluorocarbon polymer, or other material that minimizes adsorption of analytes, of minimal length.

<sup>4</sup> Code of Federal Regulations 40 CFR Part 136, Appendix A, available from Superintendent of Documents, U.S. Government Printing Office, Washington, DC 20402.

7.2.6 *Sample Condenser System*, a refrigeration unit capable of reducing and removing the moisture of the sample gas to a level acceptable for sample injection.

7.2.7 *Sample Flow Rotameters*, capable of withstanding sample gas conditions, calibrated in accordance with Practice D3195.

7.2.8 *Sample Transfer Line*, to transport sample from sample interface to GCMS, heated to prevent sample condensation and fabricated of stainless steel, tetrafluorocarbon polymer, or other material to minimize adsorption of analytes, of minimal length.

7.3 *Auxiliary Equipment:*

7.3.1 *Calibration Gas Manifold*, capable of delivering nitrogen or calibration gases through sampling system or directly to the instrumentation, with provisions to provide for accurate dilution of the calibration gases as necessary. See Fig. 1 for an example schematic.

7.3.2 *Mass Flow Meters or Controllers*, with a stated accuracy and calibrated range ( $\pm 2\%$  of scale from 0 to 500 mL/min or 0 to 5 L/min).

7.3.3 *Digital Bubble Meter (or equivalent)*, having a NIST-traceable calibration and accuracy of  $\pm 2\%$  of reading, with an adequate range to calibrate mass flow meters or controllers and rotameters at the specific flow rates (within  $\pm 10\%$ ) required to perform the test method.

7.3.4 *Tubing, tetrafluorocarbon polymer* (or other material), of suitable diameter and length to connect cylinder regulators and minimize the adsorption of analytes on the tubing surface.

7.3.5 *Tubing, 316 stainless steel* (or other material), of suitable diameter and length for heated connections.

7.3.6 *Gas Regulators*, appropriate for individual gas cylinders, constructed of materials that minimize adsorption of analytes.

8. Reagents and Materials

8.1 *Calibration Gases*, gas standards (in nitrogen balance or other inert gas) for those compounds identified in Section 1, certified by the manufacturer to be accurate to 5 % or better, used for the initial and continuing calibrations.

NOTE 2—The analytical accuracy of the calibration standards must be known. The analytical accuracy for gas mixtures may be concentration dependent.

8.2 *Internal Standards*, manufacturer-certified mixtures for co-injection with sample gas.

8.3 *High Purity (HP) Nitrogen or Zero Air*, for purging sample lines and sampling system components, dilutions, and blank runs.

9. Hazards

9.1 *Target Analytes*—Many of the compounds listed in Section 1 are toxic and carcinogenic. Therefore, avoid exposure to these chemicals. Calibration standards are contained in compressed gas cylinders; exercise appropriate safety precautions to avoid accidents in their transport and use.

9.2 *Sampling Location*—This test method may involve sampling locations with high positive or negative pressures, high temperatures, elevated heights, or high concentrations of hazardous or toxic pollutants.

9.3 *Mobile or Remote Laboratory*—To avoid exposure to hazardous pollutants and to protect personnel in the laboratory, perform a leak check of the sampling system and inspect the sample exhaust equipment before sampling the calibration standards or effluent. Properly vent the exhaust gases.

10. Calibration and Standardization

10.1 *Calibration Standards*—Because of the incompatibility of some target compounds, many gas blends at each concentration may be needed to construct a calibration curve

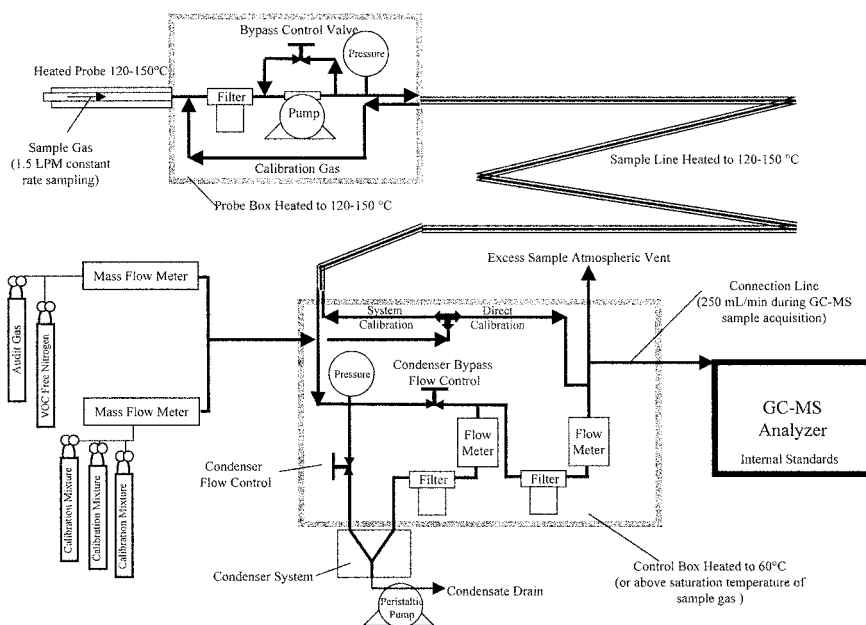

FIG. 1 Example Direct Interface GCMS Measurement System