

---

---

**Geotechnical investigation and testing —  
Laboratory testing of soil —**

**Part 10:  
Direct shear tests**

*Reconnaissance et essais géotechniques — Essais de sol au  
laboratoire —*

**iTeh STANDARD PREVIEW**  
*Partie 10: Essai de cisaillement direct*  
**(standards.iteh.ai)**

[ISO/TS 17892-10:2004](https://standards.iteh.ai/catalog/standards/sist/27e28553-4fa5-4c27-9eed-03ffbcd19a8a/iso-ts-17892-10-2004)

<https://standards.iteh.ai/catalog/standards/sist/27e28553-4fa5-4c27-9eed-03ffbcd19a8a/iso-ts-17892-10-2004>



**PDF disclaimer**

This PDF file may contain embedded typefaces. In accordance with Adobe's licensing policy, this file may be printed or viewed but shall not be edited unless the typefaces which are embedded are licensed to and installed on the computer performing the editing. In downloading this file, parties accept therein the responsibility of not infringing Adobe's licensing policy. The ISO Central Secretariat accepts no liability in this area.

Adobe is a trademark of Adobe Systems Incorporated.

Details of the software products used to create this PDF file can be found in the General Info relative to the file; the PDF-creation parameters were optimized for printing. Every care has been taken to ensure that the file is suitable for use by ISO member bodies. In the unlikely event that a problem relating to it is found, please inform the Central Secretariat at the address given below.

**iTeh STANDARD PREVIEW**  
**(standards.iteh.ai)**

[ISO/TS 17892-10:2004](https://standards.iteh.ai/catalog/standards/sist/27e28553-4fa5-4c27-9eed-03ffbcd19a8a/iso-ts-17892-10-2004)

<https://standards.iteh.ai/catalog/standards/sist/27e28553-4fa5-4c27-9eed-03ffbcd19a8a/iso-ts-17892-10-2004>

© ISO 2004

All rights reserved. Unless otherwise specified, no part of this publication may be reproduced or utilized in any form or by any means, electronic or mechanical, including photocopying and microfilm, without permission in writing from either ISO at the address below or ISO's member body in the country of the requester.

ISO copyright office  
Case postale 56 • CH-1211 Geneva 20  
Tel. + 41 22 749 01 11  
Fax + 41 22 749 09 47  
E-mail [copyright@iso.org](mailto:copyright@iso.org)  
Web [www.iso.org](http://www.iso.org)

Published in Switzerland

## Foreword

ISO (the International Organization for Standardization) is a worldwide federation of national standards bodies (ISO member bodies). The work of preparing International Standards is normally carried out through ISO technical committees. Each member body interested in a subject for which a technical committee has been established has the right to be represented on that committee. International organizations, governmental and non-governmental, in liaison with ISO, also take part in the work. ISO collaborates closely with the International Electrotechnical Commission (IEC) on all matters of electrotechnical standardization.

International Standards are drafted in accordance with the rules given in the ISO/IEC Directives, Part 2.

The main task of technical committees is to prepare International Standards. Draft International Standards adopted by the technical committees are circulated to the member bodies for voting. Publication as an International Standard requires approval by at least 75 % of the member bodies casting a vote.

In other circumstances, particularly when there is an urgent market requirement for such documents, a technical committee may decide to publish other types of normative document:

- an ISO Publicly Available Specification (ISO/PAS) represents an agreement between technical experts in an ISO working group and is accepted for publication if it is approved by more than 50 % of the members of the parent committee casting a vote.
- an ISO Technical Specification (ISO/TS) represents an agreement between the members of a technical committee and is accepted for publication if it is approved by 2/3 of the members of the committee casting a vote.

ISO/TS 17892-10:2004

An ISO/PAS or ISO/TS is reviewed after three years with a view to deciding whether it should be confirmed for a further three years, revised to become an International Standard, or withdrawn. In the case of a confirmed ISO/PAS or ISO/TS, it is reviewed again after six years at which time it has to be either transposed into an International Standard or withdrawn.

Attention is drawn to the possibility that some of the elements of this document may be the subject of patent rights. ISO shall not be held responsible for identifying any or all such patent rights.

ISO/TS 17892-10 was prepared by the European Committee for Standardization (CEN) in collaboration with Technical Committee ISO/TC 182, *Geotechnics*, Subcommittee SC 1, *Geotechnical investigation and testing*, in accordance with the Agreement on technical cooperation between ISO and CEN (Vienna Agreement).

Throughout the text of this document, read "...this European pre-Standard..." to mean "...this Technical Specification...".

ISO 17892 consists of the following parts, under the general title *Geotechnical investigation and testing — Laboratory testing of soil*:

- *Part 1: Determination of water content*
- *Part 2: Determination of density of fine-grained soil*
- *Part 3: Determination of particle density — Pycnometer method*
- *Part 4: Determination of particle size distribution*
- *Part 5: Incremental loading oedometer test*
- *Part 6: Fall cone test*

- *Part 7: Unconfined compression test on fine-grained soil*
- *Part 8: Unconsolidated undrained triaxial test*
- *Part 9: Consolidated triaxial compression tests on water-saturated soil*
- *Part 10: Direct shear tests*
- *Part 11: Determination of permeability by constant and falling head*
- *Part 12: Determination of the Atterberg limits*

**iTeh STANDARD PREVIEW**  
**(standards.iteh.ai)**

[ISO/TS 17892-10:2004](https://standards.iteh.ai/catalog/standards/sist/27e28553-4fa5-4c27-9eed-03ffbcd19a8a/iso-ts-17892-10-2004)

<https://standards.iteh.ai/catalog/standards/sist/27e28553-4fa5-4c27-9eed-03ffbcd19a8a/iso-ts-17892-10-2004>

## Contents

Page

Foreword.....	vi
1 Scope .....	1
2 Normative references .....	1
3 Terms and definitions .....	1
4 Equipment .....	2
5 Specimen .....	5
6 Test procedure .....	6
7 Test results.....	8
8 Test report .....	10
Bibliography .....	12

## Figures

Figure 1 — Schematic drawing of a conventional and a parallel controlled shearbox.....	3
Figure 2 — Example of a ring shear apparatus .....	4
Figure 3 — Example of time-settlement-curve to determine the time for primary consolidation .....	6
Figure 4 — Determination of the friction angle $\phi'$ as a function of the void ratio $e$ .....	10

## Foreword

This document (CEN ISO/TS 17892-10:2004) has been prepared by Technical Committee CEN/TC 341 "Geotechnical investigation and testing", the secretariat of which is held by DIN, in collaboration with Technical Committee ISO/TC 182 "Geotechnics".

According to the CEN/CENELEC Internal Regulations, the national standards organizations of the following countries are bound to announce this Technical Specification: Austria, Belgium, Cyprus, Czech Republic, Denmark, Estonia, Finland, France, Germany, Greece, Hungary, Iceland, Ireland, Italy, Latvia, Lithuania, Luxembourg, Malta, Netherlands, Norway, Poland, Portugal, Slovakia, Slovenia, Spain, Sweden, Switzerland and United Kingdom.

CEN ISO/TS 17892 consists of the following parts, under the general title *Geotechnical investigation and testing — Laboratory testing of soil*:

- *Part 1: Determination of water content*
- *Part 2: Determination of density of fine-grained soil*
- *Part 3: Determination of particle density - Pycnometer method*
- *Part 4: Determination of particle size distribution*
- *Part 5: Incremental loading oedometer test*
- *Part 6: Fall cone test*
- *Part 7: Unconfined compression test on fine-grained soil*
- *Part 8: Unconsolidated undrained triaxial test*
- *Part 9: Consolidated triaxial compression tests on water-saturated soil*
- *Part 10: Direct shear tests*
- *Part 11: Determination of permeability by constant and falling head*
- *Part 12: Determination of Atterberg limits*

STANDARD PREVIEW  
(standards.iteh.ai)  
ISO/TS 17892-10:2004  
<https://standards.iteh.ai/catalog/standards/sist/27e28553-4fa5-4c27-9eed-637e428117892-10-2004>

## Introduction

This document covers areas in the international field of geotechnical engineering never previously standardised. It is intended that this document presents broad good practice throughout the world and significant differences with national documents is not anticipated. It is based on international practice (see [1]).

# iTeh STANDARD PREVIEW (standards.iteh.ai)

[ISO/TS 17892-10:2004](https://standards.iteh.ai/catalog/standards/sist/27e28553-4fa5-4c27-9eed-03ffbcd19a8a/iso-ts-17892-10-2004)

<https://standards.iteh.ai/catalog/standards/sist/27e28553-4fa5-4c27-9eed-03ffbcd19a8a/iso-ts-17892-10-2004>

**iTeh STANDARD PREVIEW**  
**(standards.iteh.ai)**

[ISO/TS 17892-10:2004](#)

<https://standards.iteh.ai/catalog/standards/sist/27e28553-4fa5-4c27-9eed-03ffbcd19a8a/iso-ts-17892-10-2004>



## 1 Scope

This document specifies laboratory test methods to establish the effective shear strength parameter for soils within the scope of the geotechnical investigations according to prEN 1997-1 and -2.

The test method consists of placing the test specimen in the direct shear device, applying a pre-determined normal stress, providing for draining (and wetting if required) of the test specimen, or both, consolidating the specimen under normal stress, unlocking the frames that hold the specimen, and displacing one frame horizontally with respect to the other at a constant rate of shear-deformation and measuring the shearing force, and horizontal displacements as the specimen is sheared. Shearing is applied slowly enough to allow excess pore pressures to dissipate by drainage so that effective stresses are equal to total stresses.

Direct shear tests are used in earthworks and foundation engineering for the determination of the effective shear strength of soils.

## 2 Normative references

The following referenced documents are indispensable for the application of this document. For dated references, only the edition cited applies. For undated references, the latest edition of the referenced document (including any amendments) applies.

prEN 1997-1, *Eurocode 7: Geotechnical design — Part 1: General rules*.

prEN 1997-2, *Eurocode 7: Geotechnical design — Part 2: Ground investigation and testing*.

CEN ISO/TS 17892-1, *Geotechnical investigation and testing — Laboratory testing of soil — Part 1: Determination of water content (ISO/TS 17892-1:2004)*

[ISO/TS 17892-10:2004](https://standards.iteh.ai/catalog/standards/sist/27e28553-4fa5-4c27-9eed-03ffbcd19a8a/iso-ts-17892-10-2004)

<https://standards.iteh.ai/catalog/standards/sist/27e28553-4fa5-4c27-9eed-03ffbcd19a8a/iso-ts-17892-10-2004>

## 3 Terms and definitions

For the purposes of this document, the following terms and definitions apply.

### 3.1

#### direct shear test

test whereby a square or circular prism or annular specimen of soil is laterally restrained and sheared along a mechanically induced horizontal plane while subjected to a pressure applied normal to that plane

### 3.2

#### shearbox test

direct shear test whereby a specimen is placed in a rigid container (shearbox) which is square or circular and divided horizontally into two halves.

NOTE Shearing is applied by displacing the two halves of the shearbox relative to each other (see Figure 1)

### 3.3

#### ring shear test

direct shear test whereby an annular specimen is subjected to rotational shear while subjected to vertical stress (see Figure 2)

### 3.4

#### friction angle

$\phi'$   
angle of friction, as determined from effective stresses

### 3.5

#### cohesion

$c'$   
cohesion intercept, as determined from effective stresses

## 4 Equipment

### 4.1 Shearbox

**4.1.1** The shearbox shall be square or circular in plan and divided horizontally into two rigid halves which prevent horizontal deformation of the specimen.

**4.1.2** Arrangements shall be provided for locking the two halves of the shearbox securely together while the specimen is being placed, and for lifting the upper half of the box from the lower half by a small controlled vertical displacement without tilt, after applying vertical load to the specimen.

**4.1.3** The arrangement shall be such that when released one half of the shearbox shall be able to move exactly parallel to the other half.

**4.1.4** The loading cap shall be 0,5 mm smaller in plan than the internal dimensions of the shearbox and be rigid enough to transmit the vertical load uniformly to the specimen.

**4.1.5** The loading cap should preferably be guided by a bearing to prevent tilting during shear.

**iTeh STANDARD PREVIEW**  
**(standards.iteh.ai)**

[ISO/TS 17892-10:2004](https://standards.iteh.ai/catalog/standards/sist/27e28553-4fa5-4c27-9eed-03ffbcd19a8a/iso-ts-17892-10-2004)

<https://standards.iteh.ai/catalog/standards/sist/27e28553-4fa5-4c27-9eed-03ffbcd19a8a/iso-ts-17892-10-2004>

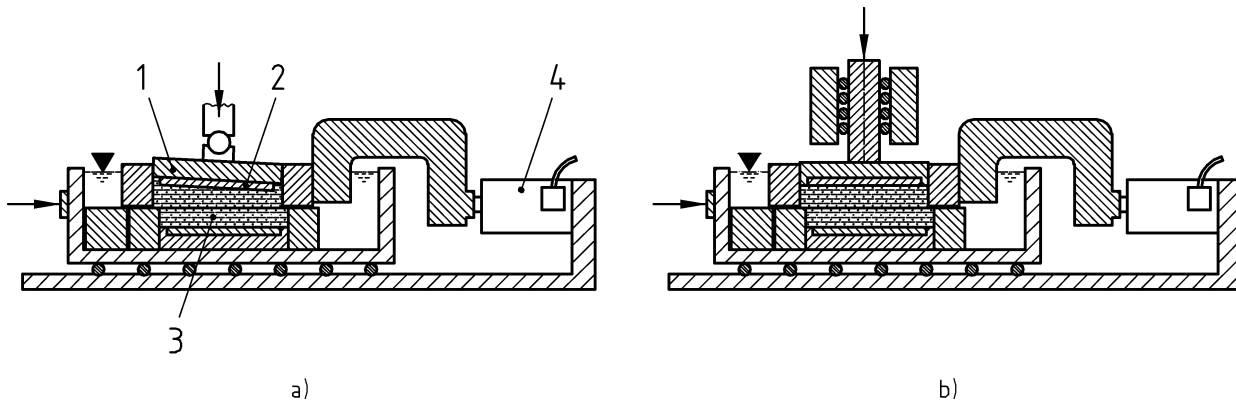

### Key

- a) conventional device
- b) parallel controlled device
- 1) loading pad
- 2) porous plate
- 3) soil specimen
- 4) force transducer

**Figure 1 — Schematic drawing of a conventional and a parallel controlled shearbox**

**4.1.6** During testing, the shear box shall be placed in an outer container (the carriage), such that the test specimen is submerged under water during the test.

**4.1.7** The carriage shall be supported on the bed of the machine by a low-friction bearing which allows movement in the longitudinal direction only.

**4.1.8** To achieve a uniform distribution of the shear stresses over the plan of the specimen rough porous filter plates shall cover the upper and the lower surface of the specimen. The porous plates shall be of a material which does not react chemically with the pore water or the soil. Their porosity shall prevent intrusions of soil into the pores, but shall allow free drainage of water throughout the test. Therefore the permeability of the porous platens shall be at least 10 times the permeability of the specimen.

**4.1.9** Typical arrangements for a conventional and a parallel controlled shearbox are shown in Figure 1.

**NOTE** A parallel controlled shear box allows a correct simulation of in-situ shearing when shear planes occur. Investigations show that with cohesive soils the friction angle  $\varphi$  is up to  $4^\circ$  smaller and with non-cohesive soils it is up to  $6^\circ$  higher in a parallel controlled shearbox than in a conventional apparatus.

## 4.2 Ring shear apparatus

**4.2.1** The apparatus shall be constructed such that shearing forces are purely torsional.

**4.2.2** The soil container rings shall be of sufficient stiffness to prevent radial deformation of the specimen.

**4.2.3** The soil container rings shall be integrated in a water bath which allows the specimen to be submerged during the test.

**4.2.4** The upper and lower rings shall be fitted with porous platens having the same properties as those in the shear box (see 4.1.8).

**4.2.5** The ring shear apparatus shall contain a device for application of vertical (normal) stresses.

**4.2.6** A typical arrangement for a ring shear apparatus is shown in Figure 2.