



Designation: E1614 – 94(Reapproved 2004)

Standard Guide for Procedure for Measuring Ionizing Radiation-Induced Attenuation in Silica-Based Optical Fibers and Cables for Use in Remote Fiber-Optic Spectroscopy and Broadband Systems¹

This standard is issued under the fixed designation E1614; the number immediately following the designation indicates the year of original adoption or, in the case of revision, the year of last revision. A number in parentheses indicates the year of last reapproval. A superscript epsilon (ϵ) indicates an editorial change since the last revision or reapproval.

1. Scope

1.1 This guide covers a method for measuring the real time, in situ radiation-induced spectral attenuation of multimode, step index, silica optical fibers transmitting unpolarized light. This procedure specifically addresses steady-state ionizing radiation (that is, alpha, beta, gamma, protons, etc.) with appropriate changes in dosimetry, and shielding considerations, depending upon the irradiation source.

1.2 This test procedure is not intended to test the balance of the optical and non-optical components of an optical fiber-based system, but may be modified to test other components in a continuous irradiation environment.

1.3 The values stated in SI units are to be regarded as standard.

1.4 *This standard does not purport to address all of the safety concerns, if any, associated with its use. It is the responsibility of the user of this standard to establish appropriate safety and health practices and determine the applicability of regulatory limitations prior to use.*

2. Referenced Documents

2.1 Test or inspection requirements include the following references:

2.2 *Military Standard:*

[MIL-STD-2196-\(SH\) Glossary of Fiber Optic Terms²](#)

2.3 *EIA Standards:*

[EIA-455-57 Optical Fiber End Preparation and Examination³](#)

¹ This guide is under the jurisdiction of ASTM Committee E-13 on Molecular Spectroscopy and is the direct responsibility of Subcommittee E13.09 on Fiber Optics in Molecular Spectroscopy.

Current edition approved Nov. 1, 2004. Published January 2005. Originally approved in 1994. Last previous edition approved in 1999 as E1614-94 (1999). DOI: 10.1520/E1614-94R04.

² Available from Standardization Documents Order Desk, Bldg. 4 Section D, 700 Robbins Ave., Philadelphia, PA 19111-5094, Attn: NPODS.

³ Available from Electronic Industry Association, 1990 M St. N.W., Suite 400, Washington, DC 20036.

[EIA-455-64 Procedure for Measuring Radiation-Induced Attenuation in Optical Fibers and Cables³](#)

[EIA-455-78A-90 Spectral Attenuation Cutback Measurement for Single-Mode Optical Fibers³](#)

3. Terminology

3.1 *Definitions:*

3.1.1 Refer to MIL-STD-2196 for the definition of terms used in this guide.

4. Significance and Use

4.1 Ionizing environments will affect the performance of optical fibers/cables being used to transmit spectroscopic information from a remote location. Determination of the type and magnitude of the spectral attenuation or interferences, or both, produced by the ionizing radiation in the fiber is necessary for evaluating the performance of an optical fiber sensor system.

4.2 The results of the test can be utilized as a selection criteria for optical fibers used in optical fiber spectroscopic sensor systems.

NOTE 1—The attenuation of optical fibers generally increases when exposed to ionizing radiation. This is due primarily to the trapping of radiolytic electrons and holes at defect sites in the optical materials, that is, the formation of color centers. The depopulation of these color centers by thermal and/or optical (photobleaching) processes, or both, causes recovery, usually resulting in a decrease in radiation-induced attenuation. Recovery of the attenuation after irradiation depends on many variables, including the temperature of the test sample, the composition of the sample, the spectrum and type of radiation employed, the total dose applied to the test sample, the light level used to measure the attenuation, and the operating spectrum. Under some continuous conditions, recovery is never complete.

5. Apparatus

5.1 The test schematic is shown in Fig. 1. The following list identifies the equipment necessary to accomplish this test procedure.

5.2 *Light Source*—The light source should be chosen so that the spectral region of interest is provided. Lamps or globars, or

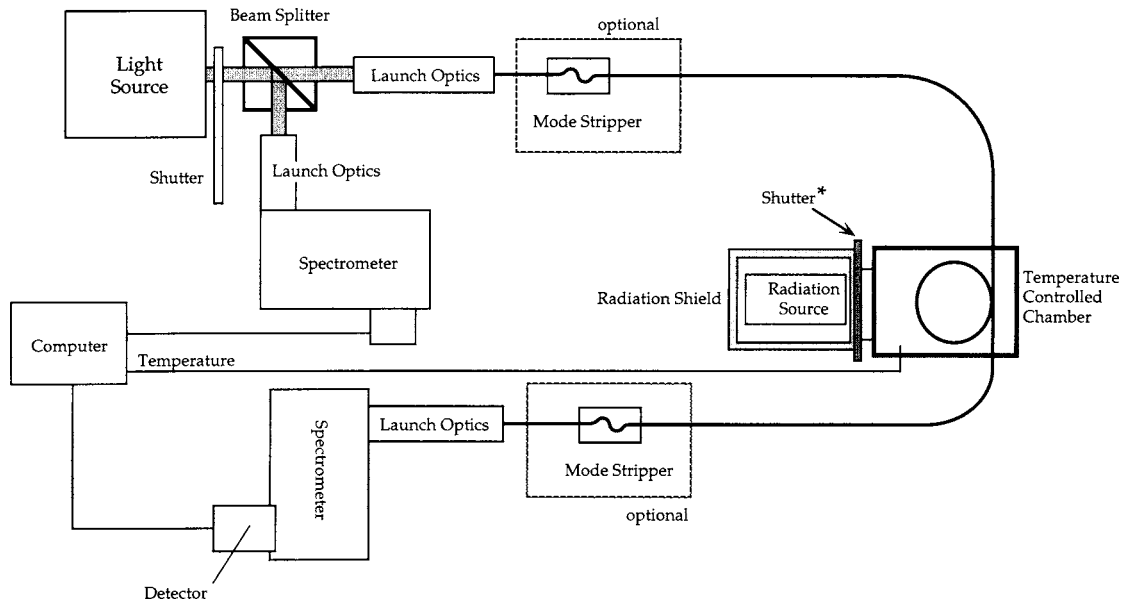

NOTE 1—If a shuttered source is not used, the test engineer must account for the placement and extraction of the test sample in the irradiator.

FIG. 1 Schematic Instrumentation Diagram

both, may be used for analysis as long as they satisfy the power, stability, and system requirements defined. In general, the silica fibers should be evaluated from ≈ 350 to ≈ 2100 nm, therefore, more than one light source or multiple testing, or both, may be necessary.

5.3 *Shutter*—In order to determine the background stability, the light will have to be blocked from entering the optical fiber by a shutter.

5.4 *Focusing/Collection Optics*—A number of optical elements may be needed for the launch and collection of light radiation into/from the test optical fiber and other instrumentation (light source, spectrometer, detector). The minimal requirement for these elements shall be that the numerical aperture of the adjacent components are matched for efficient coupling.

5.5 *Mode Stripper*—High-order cladding modes must be attenuated by mode stripping, and mode stripping should occur prior to and after the radiation chamber, especially if the fiber length is shorter than that specified in this guide. If it is found that the coating material effectively strips the cladding modes from the optical fiber, then a mode stripper is not necessary.

5.6 *Light Radiation Filtering*—Filters may be necessary to restrict unwanted regions of the light spectrum. They may be needed to avoid saturation or nonlinearities of the detector and recording instrumentation by transient light sources (Cerenkov or other luminescence phenomena), or due to wide spectral power variances with the output of the broadband sources.

5.7 *Optical Splitter*—An optical splitter or fiber optic coupler shall divert some portion of the input light to a reference detector for monitoring the stability of the light source.

5.8 *Optical Interconnections*—The input and output ends of the optical fiber shall have a stabilized optical interconnection, such as a clamp, connector, splice, or weld. During an attenuation measurement, the interconnection shall not be

changed or adjusted. If possible, the optical interconnections should not be within the irradiation region.

5.9 *Wavelength Demultiplexor*—A means of separating the spectral information must be used at the detector end of the system so that multiple wavelengths can be simultaneously evaluated (that is, grating, prism, Acousto-optic tunable filter, etc.).

5.10 *Optical Detection*—The optical detection system shall be wavelength calibrated in accordance with the manufacturer's recommended procedure utilizing standard spectral line sources. The calibration and spectral response of the detection systems should be documented.

5.10.1 *Sample Detector*—An optical detector that is linear and stable over the range of intensities that are encountered shall be used. The method employed must be able to evaluate a wide spectral range rapidly (that is, 500 ms). The primary requirement of the detector is that the spectral detectivity corresponds to the spectral transmission of the light source/fiber system and that a spectral resolution of ± 10 nm is attainable.

5.10.2 *Reference Detector*—The reference detector is used for light source stability measurements for the wavelength range of interest. The reference detection system should have a similar response to the sample detection system. If an optical fiber splitter is used for the reference arm of the detection scheme, then the detection system must be able to accept the output from an optical fiber. If the detection scheme can monitor the output of two optical fibers (for example, a CCD detector with an imaging spectrometer), it may be advantageous to package the reference fiber and sample fiber in the same termination so that a single detection system can simultaneously monitor both outputs. This configuration is optional.

5.11 *Recorder System*—A suitable data recording system, such as a computer data acquisition system, is recommended due to the large spectral data sets necessary.

5.12 *Ambient Light Shielding*—The irradiated fiber length shall be shielded from ambient light to prevent photobleaching by any external light sources and to avoid baseline shifts in the zero light level. An absorbing fiber coating or jacket can be used as the light shield, provided that it has been demonstrated to block ambient light and that its influence on the dose within the fiber core has been taken into consideration.

5.13 *Irradiation System*—The irradiation system should have the following characteristics:

5.13.1 *Dose Rate*—A Co^{60} or other irradiation source shall be used to deliver radiation at dose rates ranging from 10 to 100 Gy(SiO_2)/min (see [Note 3](#)).

5.13.2 *Radiation Energy*—The energy of the gamma rays emitted by the source should be greater than 500 KeV to avoid serious complications with the rapid variations in total dose as a function of depth within the test sample.

5.13.3 *Radiation Dosimeter*—Dosimetry traceable to national standards shall be used. Dose should be measured in the same uniform geometry as the actual fiber core material to ensure that dose-build-up effects are comparable to the fiber core and the dosimeter. The dose should be expressed in gray calculated for the core material.

5.14 *Temperature-Controlled Container*—Unless otherwise specified, the temperature-controlled container shall have the capability of maintaining the specified temperature to $23 \pm 2^\circ\text{C}$. The temperature of the sample/container should be monitored prior to and during the test.

NOTE 2—The wavelength range indicated in [5.2](#) is the largest range that should be tested if the equipment (that is, sources, detectors) is available. Silica glass will transmit from ≈ 190 to ≈ 3300 nm, but this range is not practical for optical fiber applications due to the high attenuations in the ultraviolet (UV) and near-infrared (NIR). The widest wavelength range that can be tested that satisfies the requirements of the test procedure should be evaluated if the equipment is available.

NOTE 3—The average total dose should be expressed in Gray (Gy, where 1 Gy = 100 rads) to a precision of $\pm 5\%$, traceable to national standards. For typical silica core fibers, dose should be expressed in Gy calculated for SiO_2 , that is, Gy(SiO_2).

6. Hazards

6.1 Carefully trained and qualified personnel must be used to perform this test procedure since radiation (both ionizing and optical), as well as electrical, hazards will be present.

7. Test Specimens

7.1 *Sample Optical Fiber*—The sample fiber shall be a previously unirradiated, silica-based, step-index, multimode fiber. The fiber shall be long enough to allow coupling between the optical instrumentation outside the radiation chamber and the sample area, along with an irradiated test length of 50 ± 5 m.

7.2 The test specimen may be an optical fiber cable assembly, as long as the cable contains the above specified fiber for analysis as in [7.1](#).

7.3 *Test Reel*—The test reel shall not act as a shield for the radiation used in this test or, alternatively, the dose must be measured in a geometry duplicating the effects of reel attenuation. The diameter of the test reel and the winding tension of

the fiber can influence the observed radiation performance, therefore, the fiber should be loosely wound on a reel diameter exceeding 10 cm.

7.4 *Fiber End Preparation*—The test sample shall be prepared such that its end faces are smooth and perpendicular to the fiber axis, in accordance with EIA-455-57.

8. Radiation Calibration and Stability

8.1 *Calibration of Radiation Source*—Calibration of the radiation source for dose uniformity and dose level shall be made at the location of the device under test (DUT) and at a minimum of four locations, prior to introduction of fiber test samples. The variation in dose across the fiber reel volume shall not exceed $\pm 10\%$. If thermoluminescent detectors (TLDs) are used for the measurements, four TLDs shall be used to sample dose distribution at each location. The readings from the multiple TLDs at each location shall be averaged to minimize dose uncertainties. To maintain the highest possible accuracy in dose measurements, the TLDs shall not be used more than once. TLDs should be used only in the dose region where they maintain a linear response.

8.2 The total dose shall be measured with an irradiation time equal to subsequent fiber measurements. Alternatively, the dose rate may be measured and the total dose calculated from the product of the dose rate and irradiation time. Source transit time (from off-to-on and on-to-off positions) shall be less than 5 % of the irradiation time.

8.3 *Stability of Radiation Source*—The dose rate must be constant for at least 95 % of the shortest irradiation time of interest. The dose variation provided across the fiber sample shall not exceed $\pm 10\%$.

9. Procedure

9.1 Place the reel of fiber or cable in the attenuation test setup as shown in [Fig. 1](#). Couple the light source into the end of the test fiber, and position the light exiting the fiber for collection by the spectrograph or other appropriate detection system.

9.2 *Temperature Stability*—Stabilize the test sample in the temperature chamber at $23 \pm 2^\circ\text{C}$ prior to proceeding.

9.3 *System Stability*—Verify the stability of the total system under illumination conditions prior to any measurement for a time exceeding that required for determination of $P_b(\lambda)$ and $P(t, \lambda)$ (see [10.1](#)) during the duration of the attenuation measurement.

9.4 For stability measurements, the system output need only be evaluated in 50-nm increments over the useful range of the detection system. At each wavelength, convert the maximum fluctuation in the observed system output during that time, into an apparent change in optical attenuation due to system noise, $\Delta\alpha_n(t, \lambda)$, using [Eq 1](#). Any subsequent measurement must be rejected if the observed $\Delta A(t, \lambda)$ (defined in [10.1](#)) does not exceed $10 \times \Delta\alpha_n(t, \lambda)$.

9.5 *Baseline Stability*—Also verify the baseline stability for a time comparable to the attenuation measurement with the light source blocked off. Record the baseline output power, P_n ,