



# SLOVENSKI STANDARD

## SIST EN 1109:2013

01-september-2013

Nadomešča:  
SIST EN 1109:2000

---

### Hidroizolacijski trakovi - Bitumenski trakovi za tesnjenje streh - Ugotavljanje upogljivosti pri nizki temperaturi

Flexible sheets for waterproofing - Bitumen sheets for roof waterproofing - Determination of flexibility at low temperature

Abdichtungsbahnen - Bitumenbahnen für Dachabdichtungen - Bestimmung des Kaltbiegeverhaltens

Feuilles souples d'étanchéité - Feuilles d'étanchéité de toiture bitumineuses - Détermination de la souplesse à basse température

Ta slovenski standard je istoveten z: **EN 1109:2013**

---

#### **ICS:**

91.060.20	Strehe	Roofs
91.100.50	Veziva. Tesnilni materiali	Binders. Sealing materials

**SIST EN 1109:2013** en,fr,de

**iTeh STANDARD PREVIEW**  
**(standards.iteh.ai)**

SIST EN 1109:2013

<https://standards.iteh.ai/catalog/standards/sist/edb27608-ab67-4923-8d0f-1cb3734f00c5/sist-en-1109-2013>

EUROPEAN STANDARD

EN 1109

NORME EUROPÉENNE

EUROPÄISCHE NORM

April 2013

ICS 91.100.50

Supersedes EN 1109:1999

English Version

## Flexible sheets for waterproofing - Bitumen sheets for roof waterproofing - Determination of flexibility at low temperature

Feuilles souples d'étanchéité - Feuilles d'étanchéité de toiture bitumineuses - Détermination de la souplesse à basse température

Abdichtungsbahnen - Bitumenbahnen für Dachabdichtungen - Bestimmung des Kaltbiegeverhaltens

This European Standard was approved by CEN on 14 March 2013.

CEN members are bound to comply with the CEN/CENELEC Internal Regulations which stipulate the conditions for giving this European Standard the status of a national standard without any alteration. Up-to-date lists and bibliographical references concerning such national standards may be obtained on application to the CEN-CENELEC Management Centre or to any CEN member.

This European Standard exists in three official versions (English, French, German). A version in any other language made by translation under the responsibility of a CEN member into its own language and notified to the CEN-CENELEC Management Centre has the same status as the official versions.

CEN members are the national standards bodies of Austria, Belgium, Bulgaria, Croatia, Cyprus, Czech Republic, Denmark, Estonia, Finland, Former Yugoslav Republic of Macedonia, France, Germany, Greece, Hungary, Iceland, Ireland, Italy, Latvia, Lithuania, Luxembourg, Malta, Netherlands, Norway, Poland, Portugal, Romania, Slovakia, Slovenia, Spain, Sweden, Switzerland, Turkey and United Kingdom.

[SIST EN 1109:2013](https://standards.iteh.ai/catalog/standards/sist/edb27608-ab67-4923-8d0f-1cb3734f00c5/sist-en-1109-2013)

<https://standards.iteh.ai/catalog/standards/sist/edb27608-ab67-4923-8d0f-1cb3734f00c5/sist-en-1109-2013>



EUROPEAN COMMITTEE FOR STANDARDIZATION  
COMITÉ EUROPÉEN DE NORMALISATION  
EUROPÄISCHES KOMITEE FÜR NORMUNG

Management Centre: Avenue Marnix 17, B-1000 Brussels

<b>Contents</b>	<b>Page</b>
Foreword.....	3
Introduction .....	4
1 Scope .....	5
2 Normative references .....	5
3 Terms and definitions .....	5
4 Principle.....	5
5 Apparatus .....	6
6 Sampling.....	7
7 Preparation of test specimens .....	7
8 Procedure .....	7
8.1 Preparation of apparatus .....	7
8.2 Conditioning of test specimens .....	8
8.3 Flexibility at a specified temperature.....	8
8.4 Determination of cold bending temperature.....	8
9 Recording of results, evaluation and precision of test method .....	8
9.1 Result of flexibility at a specified temperature .....	8
9.2 Results when determining cold bending temperature.....	8
9.3 Precision of the measuring method.....	9
9.3.1 General.....	9
9.3.2 Repeatability EN 1109:1999 .....	9
9.3.3 Reproducibility EN 1109:1999 .....	9
10 Test report .....	9
Bibliography .....	10

## Foreword

This document (EN 1109:2013) has been prepared by Technical Committee CEN/TC 254 “Flexible sheets for waterproofing”, the secretariat of which is held by NEN.

This European Standard shall be given the status of a national standard, either by publication of an identical text or by endorsement, at the latest by October 2013, and conflicting national standards shall be withdrawn at the latest by October 2013.

Attention is drawn to the possibility that some of the elements of this document may be the subject of patent rights. CEN [and/or CENELEC] shall not be held responsible for identifying any or all such patent rights.

This document supersedes EN 1109:1999.

The significant change made since this previous version is:

— the change of the coolant to be used.

According to the CEN-CENELEC Internal Regulations, the national standards organizations of the following countries are bound to implement this European Standard: Austria, Belgium, Bulgaria, Croatia, Cyprus, Czech Republic, Denmark, Estonia, Finland, Former Yugoslav Republic of Macedonia, France, Germany, Greece, Hungary, Iceland, Ireland, Italy, Latvia, Lithuania, Luxembourg, Malta, Netherlands, Norway, Poland, Portugal, Romania, Slovakia, Slovenia, Spain, Sweden, Switzerland, Turkey and the United Kingdom.

(standards.iteh.ai)

SIST EN 1109:2013

<https://standards.iteh.ai/catalog/standards/sist/edb27608-ab67-4923-8d0f-1cb3734f00c5/sist-en-1109-2013>

**EN 1109:2013 (E)****Introduction**

This European Standard is intended for the characterisation and/or classification of bitumen sheets as manufactured or supplied before use. The test method relates exclusively to products, or to their components where appropriate, and not to waterproofing systems of such products and installed in the works.

This test is intended to be used in conjunctions within the relevant European products specifications for bitumen flexible sheets for waterproofing.

The test for flexibility at a low temperature is intended to determine the susceptibility to cracking of the bituminous coating on a sheet when bent under specified conditions. The test result is dependent on the type of coating, on the thickness of the sheet, type and position of the reinforcement and the behaviour of the surface material. The use of the test results directly to compare the performance of coatings in sheets of different composition is strictly limited because of the influence of parameters which have not been quantified. Only the results from sheets with the same composition can be used to compare the performance directly.

The test primarily serves to characterise bitumen sheets. It can be used to evaluate the change in the cold bending behaviour during artificial ageing. It is not safe to relate the test results to the actual performance to be expected at low temperatures in service.

Compared to EN 1109:1999, in this new version of EN 1109 one type of coolant is described, which will give more reliable results.

**iTeh STANDARD PREVIEW**  
**(standards.iteh.ai)**  
SIST EN 1109:2013  
<https://standards.iteh.ai/catalog/standards/sist/edb27608-ab67-4923-8d0f-1cb3734f00c5/sist-en-1109-2013>

## 1 Scope

This European Standard specifies the determination of flexibility of bitumen sheets at low temperatures. The test can be carried out on the upper or lower face of the sheet either at a predetermined temperature or successively at different temperature steps to determine the cold bending temperature which represents a limiting temperature. Therefore, the test can be used to confirm a minimum cold bending temperature for a product or to determine the specific cold bending temperature for the product e.g. to determine the change of these properties as a result of artificial ageing.

In the case of sheets with the same bituminous compound on both sides and where the reinforcement is placed in the cross section visually closer to the upper surface, the test is performed on the bottom face only.

If the upper surface is covered with a non-woven (e.g. tissue, fleece etc.) or metal facing, the test is performed on the bottom side only.

If the sheet on the upper surface is covered with permanent light surface protection and where the reinforcement is placed in the cross section visually closer to the upper surface, the test is performed on the bottom side only.

## 2 Normative references

The following documents, in whole or in part, are normatively referenced in this document and are indispensable for its application. For dated references, only the edition cited applies. For undated references, the latest edition of the referenced document (including any amendments) applies.

EN 13416, *Flexible sheets for waterproofing — Bitumen, plastic and rubber sheets for roof waterproofing — Rules for sampling*

[SIST EN 1109:2013](https://standards.iteh.ai/catalog/standards/sist/edb27608-ab67-4923-8d0f-1cb3734f00c5/sist-en-1109-2013)

## 3 Terms and definitions

<https://standards.iteh.ai/catalog/standards/sist/edb27608-ab67-4923-8d0f-1cb3734f00c5/sist-en-1109-2013>

For the purposes of this document, the following terms and definitions apply.

### 3.1

#### **flexibility**

ability of bitumen sheet test specimens to be bent under specified conditions without cracking

### 3.2

#### **cold bending temperature**

lowest temperature at which bitumen sheet test specimens can be bent around specified mandrel without cracking

### 3.3

#### **crack**

fissure in the coating of the bitumen sheet extending to the reinforcement or completely through unreinforced sheets

## 4 Principle

The test specimens taken from the test sample are bent through an angle of 180° in a mechanical bending apparatus immersed in a coolant.

After bending, the test specimens are examined for the presence of cracks in the coating.

## EN 1109:2013 (E)

## 5 Apparatus

The construction and method of operation of the apparatus are shown in Figure 1. The apparatus consists of two non-rotating cylinders ( $20 \pm 0,1$ ) mm in diameter and a cylindrical or semi-cylindrical bending mandrel ( $30 \pm 0,1$ ) mm in diameter, capable of moving upwards and placed between them. The distance  $a$  between the cylinders is adjustable so that the distance between the cylinders and the bending mandrel can be adjusted to the thickness of the sheet.

The bending part of the apparatus is immersed in a thermostatic bath, the temperature of which can be controlled between  $+20\text{ }^{\circ}\text{C}$  and  $-40\text{ }^{\circ}\text{C}$  to the nearest  $0,5\text{ }^{\circ}\text{C}$ .

The coolant used shall be

- down to  $-25\text{ }^{\circ}\text{C}$ : a mixture of ethylene glycol ( $\text{CH}_2\text{OHCH}_2\text{OH}$ )/water (volume ratio 1:1);
- below  $-25\text{ }^{\circ}\text{C}$ : a mixture of ethanol/water (volume ratio 2:1).

For elastomeric modified bitumen sheets, the mixture of ethanol/water (volume ratio 2:1) can be used at any temperature. To check the test temperature, an additional thermometer capable of measuring to  $0,5\text{ }^{\circ}\text{C}$  is required; its thermo sensor shall be placed in the test medium at the same level as the test specimen.

To position the test specimens in the test liquid so that they are flat and completely immersed for conditioning, suitable removable holding devices shall be used. The holding devices should be capable of taking at least five test specimens of a series.

For the test, the bending mandrel is raised from below against the test specimen at a speed  $360\text{ mm/min}$  so that the test specimen is bent through an angle of  $180^{\circ}$ . The electronic control system shall ensure that the travel speed is maintained at  $(360 \pm 40)\text{ mm/min}$  at each phase of the bending process and at each temperature.

Cracks are detected by visual inspection without any optical aids by the person carrying out the test. To permit an accurate assessment, the travel path is defined in such a way that the test specimen projects out of the coolant at the end of the procedure. The travel section shall be limited by suitably set limit switches.

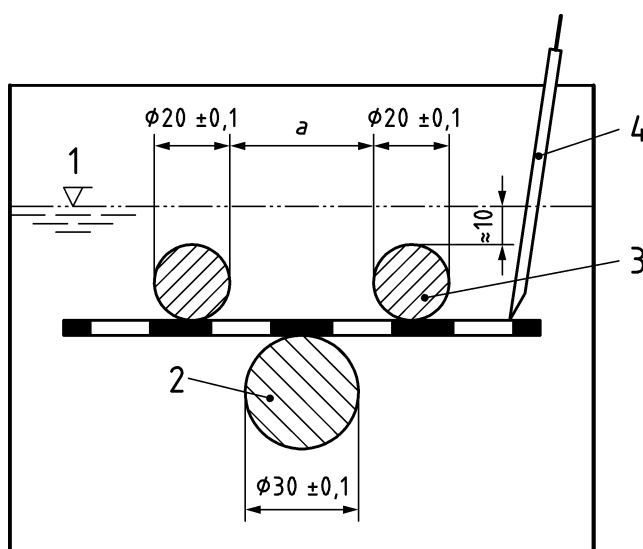

a) — Beginning of bending



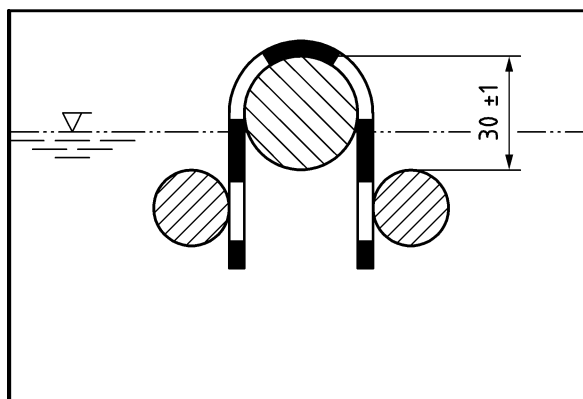

b) — End of bending

**Key**

- 1 coolant
- 2 bending mandrel
- 3 fixed cylinder
- 4 thermosensor

**Figure 1 — Principle of test apparatus and bending process****6 Sampling**

Test samples shall be taken in accordance with EN 13416.

Rectangular test specimens with dimensions of  $(140 \pm 1)$  mm  $\times$   $(50 \pm 1)$  mm as required by the tests described in 8.3 or 8.4 are taken from the test sample uniformly over the width of the sheet and with the larger dimension in the longitudinal direction of the sheet. The test specimens shall not be taken within approximately 150 mm of the edges of the sheet. The test specimens shall be numbered consecutively, beginning from one edge of the sheet, and the lower face of the sheet shall be marked.

**7 Preparation of test specimens**

Any protective film/foil shall be removed, preferably by applying a self adhesive tape to it at ambient temperature, cooling the test specimen to approximately the presumed cold bending temperature and then pulling the adhesive tape from the test specimen. Alternatively or additionally, the film can be removed by means of a compressed air jet (maximum pressure approximately 5 bar, nozzle diameter approximately 0,5 mm).

It is not permitted to remove the film/foil using heat (e.g. a gas flame).

The test specimens shall then be conditioned prior to the test for at least 4 h at  $(23 \pm 2)$  °C on a flat support so that they do not touch each other. There can be no adhesive connection with the support. Where necessary, a sheet of siliconised paper can be used. Loose surface granules shall be removed before by hand by gentle tapping.

**8 Procedure****8.1 Preparation of apparatus**

Prior to beginning the series of tests, the distance  $a$  (see Figure 1) between the cylinders shall be adjusted to the thickness of the test specimen so that it is approximately 32 mm plus twice the thickness of the test specimen. The apparatus is then placed in the refrigerant bath so that the top of the cylinders is approximately 10 mm beneath the surface of the coolant. The bending mandrel is then in the bottom position.