**Steel for the reinforcement of concrete —
Part 2:
Ribbed bars**

Aciers pour l'armature du béton —

Partie 2: Barres à verrous

**iTeh STANDARD PREVIEW
(standards.iteh.ai)**

ISO 6935-2:2007

<https://standards.iteh.ai/catalog/standards/sist/cc30f955-5a8a-42bd-a87a-b8c25db9a0cf/iso-6935-2-2007>



PDF disclaimer

This PDF file may contain embedded typefaces. In accordance with Adobe's licensing policy, this file may be printed or viewed but shall not be edited unless the typefaces which are embedded are licensed to and installed on the computer performing the editing. In downloading this file, parties accept therein the responsibility of not infringing Adobe's licensing policy. The ISO Central Secretariat accepts no liability in this area.

Adobe is a trademark of Adobe Systems Incorporated.

Details of the software products used to create this PDF file can be found in the General Info relative to the file; the PDF-creation parameters were optimized for printing. Every care has been taken to ensure that the file is suitable for use by ISO member bodies. In the unlikely event that a problem relating to it is found, please inform the Central Secretariat at the address given below.

iTeh STANDARD PREVIEW
(standards.iteh.ai)

ISO 6935-2:2007

<https://standards.iteh.ai/catalog/standards/sist/cc30f955-5a8a-42bd-a87a-b8c25db9a0cf/iso-6935-2-2007>

© ISO 2007

All rights reserved. Unless otherwise specified, no part of this publication may be reproduced or utilized in any form or by any means, electronic or mechanical, including photocopying and microfilm, without permission in writing from either ISO at the address below or ISO's member body in the country of the requester.

ISO copyright office
Case postale 56 • CH-1211 Geneva 20
Tel. + 41 22 749 01 11
Fax + 41 22 749 09 47
E-mail copyright@iso.org
Web www.iso.org

Published in Switzerland

Contents

Page

Foreword.....	iv
1 Scope	1
2 Normative references	1
3 Symbols	2
4 Terms and definitions.....	2
5 Dimensions, mass per unit length and permissible deviations.....	4
6 Requirements for ribs.....	5
7 Chemical composition.....	7
8 Mechanical properties	9
8.1 Tensile properties	9
8.2 Bending properties	10
8.3 Rebending properties after ageing	10
8.4 Fatigue properties.....	10
9 Testing	10
9.1 Tensile test	10
9.2 Bend test.....	10
9.3 Rebind test	11
9.4 Fatigue test.....	11
9.5 Chemical composition.....	11
10 Designation	11
11 Marking	12
11.1 Marking on the bar.....	12
11.2 Marking of bundles.....	12
12 Evaluation of conformity.....	12
12.1 General.....	12
12.2 Certification scheme.....	12
12.3 Acceptance testing of a specific delivery	12
Annex A (informative) Four examples of marking systems for ribbed bars	15
Annex B (informative) Options for agreement between the manufacturer and purchaser	19
Bibliography	20

Foreword

ISO (the International Organization for Standardization) is a worldwide federation of national standards bodies (ISO member bodies). The work of preparing International Standards is normally carried out through ISO technical committees. Each member body interested in a subject for which a technical committee has been established has the right to be represented on that committee. International organizations, governmental and non-governmental, in liaison with ISO, also take part in the work. ISO collaborates closely with the International Electrotechnical Commission (IEC) on all matters of electrotechnical standardization.

International Standards are drafted in accordance with the rules given in the ISO/IEC Directives, Part 2.

The main task of technical committees is to prepare International Standards. Draft International Standards adopted by the technical committees are circulated to the member bodies for voting. Publication as an International Standard requires approval by at least 75 % of the member bodies casting a vote.

Attention is drawn to the possibility that some of the elements of this document may be the subject of patent rights. ISO shall not be held responsible for identifying any or all such patent rights.

ISO 6935-2 was prepared by Technical Committee ISO/TC 17, *Steel*, Subcommittee SC 16, *Steels for the reinforcement and prestressing of concrete*.

This second edition cancels and replaces the first edition (ISO 6935-2:1991), which has been technically revised.

ISO 6935 consists of the following parts, under the general title *Steel for the reinforcement of concrete*:

— *Part 1: Plain bars*

<https://standards.iteh.ai/catalog/standards/sist/cc30f955-5a8a-42bd-a87a-b8c25db9a0cf/iso-6935-2-2007>

— *Part 2: Ribbed bars*

— *Part 3: Welded fabric*

iTeh STANDARD PREVIEW
(standards.iteh.ai)

Steel for the reinforcement of concrete —

Part 2: Ribbed bars

1 Scope

This part of ISO 6935 specifies technical requirements for ribbed bars to be used as reinforcement in concrete.

This part of ISO 6935 covers ten steel grades not intended for welding which are B300A-R, B300B-R, B300C-R, B300D-R, B400A-R, B400B-R, B400C-R, B500A-R, B500B-R and B500C-R, and eleven steel grades intended for welding which are B300DWR, B350DWR, B400AWR, B400BWR, B400CWR, B400DWR, B420DWR, B500AWR, B500BWR, B500CWR and B500DWR. The steel grades are designated with steel names allocated in accordance with ISO/TS 4949.

NOTE The first “B” stands for steel for reinforcing concrete. The next 3 digits represent the specified characteristic value of upper yield strength. The fifth symbol stands for ductility class (4.5). The sixth symbol relates to welding; “-” means not intended for welding and “W” means intended for welding. The last “R” stands for ribbed bar.

This part of ISO 6935 covers products delivered in straight lengths.

The production process is at the discretion of the manufacturer.

Ribbed bars produced from finished products, such as plates and railway rails, are excluded.

2 Normative references

The following referenced documents are indispensable for the application of this document. For dated references, only the edition cited applies. For undated references, the latest edition of the referenced document (including any amendments) applies.

ISO 404, *Steel and steel products — General technical delivery requirements*

ISO/TS 4949, *Steel names based on letter symbols*

ISO/TR 9769, *Steel and iron — Review of available methods of analysis*

ISO 10144, *Certification scheme for steel bars and wires for the reinforcement of concrete structures*

ISO 14284, *Steel and iron — Sampling and preparation of samples for the determination of chemical composition*

ISO 15630-1, *Steel for the reinforcement and prestressing of concrete — Test methods — Part 1: Reinforcing bars, wire rod and wire*

3 Symbols

The symbols used in this part of ISO 6935 are listed in Table 1.

Table 1 — Symbols

Symbol	Unit	Description	Reference
a	mm	Rib height	4.10, Clause 6
A_5	%	Percentage elongation after fracture	8.1, 9.1
A_{gt}	%	Percentage total elongation at maximum force	8.1, 9.1
A_n	mm ²	Nominal cross-sectional area	Clause 5, 9.1
c	mm	Rib spacing	4.11, Clause 6
d	mm	Nominal diameter of the bar	Clause 5, Clause 6, 9.1, 9.2, 9.3, Clause 10, 11.2,
Σf_i	mm	Ribless perimeter	4.12, Clause 6
f_k	—	Required characteristic value	12.3.2.3
f_R	—	Relative rib area	4.9, Clause 6
k, k'	—	Indices	12.3.2.3.1
m_n	—	Mean value of n individual values	12.3.2.3.1
n	—	Number of individual values	12.3.2.3.1
R_{eH}	N/mm ²	Upper yield strength	8.1
R_m	N/mm ²	Tensile strength	8.1
$R_{p0,2}$	N/mm ²	0,2 % proof strength, non-proportional extension	8.1
s_n	—	Standard deviation for n individual values	12.3.2.3.1
x_i	—	Individual value	12.3.2.3.1
α	degree	Transverse-rib flank inclination	4.14, Clause 6
β	degree	Angle between the axis of a transverse rib and the bar axis	4.15, Clause 6

4 Terms and definitions

For the purposes of this document, the following terms and definitions apply.

4.1 cast analysis

chemical analysis representative of the cast determined by the manufacturer in accordance with his own procedures

[ISO 16020:2005]

4.2 certification scheme

certification system as related to specified products, processes or services to which the same particular standards and rules, and the same procedure, apply

4.3**characteristic value**

value having a prescribed probability of not being attained in a hypothetical unlimited test series

[ISO 16020:2005]

NOTE 1 Equivalent to “fractile”, which is defined in ISO 3534-1.

NOTE 2 A nominal value is used as the characteristic value in some circumstances.

4.4**core**

part of the cross-section of the bar containing neither ribs nor indentations

NOTE Adapted from ISO 16020:2005.

4.5**ductility class**

classification of the ductility properties of reinforcing steels based on the value of the ratio of tensile strength to yield strength, as well as the elongation measured either as A_{gt} or as A_5

NOTE See Table 6.

4.6**longitudinal rib**

uniform continuous rib parallel to the axis of the bar

NOTE Adapted from ISO 16020:2005.

4.7**nominal cross-sectional area**

cross-sectional area equivalent to the area of a circular plain bar of the nominal diameter

NOTE Adapted from ISO 16020:2005.

4.8**product analysis**

chemical analysis carried out on the product

[ISO 16020:2005]

4.9**relative rib area**

f_R

area of the projections of all transverse ribs within a defined length on a plane perpendicular to the longitudinal axis of the bar, divided by this length and the nominal circumference

NOTE Adapted from ISO 16020:2005.

4.10**rib height**

a

distance from one point on the rib to the surface of the core, to be measured normal to the axis of the bar

NOTE 1 See Figure 2.

NOTE 2 Adapted from ISO 16020:2005.

**4.11
rib spacing**

c
distance between the centres of two consecutive transverse ribs measured parallel to the axis of the bar

NOTE 1 See Figure 1.

NOTE 2 Adapted from ISO 16020:2005.

**4.12
ribless perimeter**

Σf_i
sum of the distances along the surface of the core between the end of the transverse ribs of adjacent rows measured as the projection on a plane perpendicular to the axis of the bar

NOTE Adapted from ISO 16020:2005.

**4.13
transverse rib**

rib at an angle, either perpendicular or oblique, to the longitudinal axis of the bar

NOTE Adapted from ISO 16020:2005.

**4.14
transverse-rib flank inclination**

α
angle between the flank of a transverse rib and the core surface of a bar measured perpendicular to the longitudinal axis of the transverse rib

iTeh STANDARD PREVIEW
(standards.iteh.ai)

NOTE 1 See Figure 2.

[ISO 6935-2:2007](#)

NOTE 2 Adapted from ISO 16020:2005. <https://standards.iteh.ai/catalog/standards/sist/cc30f955-5a8a-42bd-a87a-b8c25db9a0cf/iso-6935-2-2007>

**4.15
transverse-rib inclination**

β
angle between the rib and the longitudinal axis of the bar

NOTE 1 See Figures 1, 3 and 4.

NOTE 2 Adapted from ISO 16020:2005.

5 Dimensions, mass per unit length and permissible deviations

Dimensions, mass per unit length and permissible deviations are given in Table 2. By agreement between the manufacturer and purchaser, ribbed bars whose nominal diameters are other than those shown in Table 2 may be used.

Table 2 — Dimensions, mass per unit length and permissible deviations

Nominal bar diameter ^a	Nominal cross-sectional area ^b	Mass per unit length	
		Requirement ^c	Permissible deviation ^d
<i>d</i> mm	<i>A_n</i> mm ²	kg/m	%
6	28,3	0,222	±8
8	50,3	0,395	±8
10	78,5	0,617	±6
12	113	0,888	±6
14	154	1,21	±5
16	201	1,58	±5
20	314	2,47	±5
25	491	3,85	±4
28	616	4,84	±4
32	804	6,31	±4
40	1 257	9,86	±4
50	1 964	15,42	±4

^a Diameters larger than 50 mm should be agreed between the manufacturer and purchaser. The permissible deviation on such bars shall be ± 4 %.

^b $A_n = 0,785 4 \times d^2$

^c Mass per unit length = $7,85 \times 10^{-3} \times A_n$

^d Permissible deviation refers to a single bar.

The delivery length is subject to agreement between the manufacturer and purchaser.

NOTE Common delivery lengths of straight bars are 6 m, 9 m, 12 m and 18 m.

Unless otherwise agreed, the permissible deviation on delivery lengths from rolling mill shall be $^{+100}_0$ mm.

6 Requirements for ribs

Ribbed bars shall have transverse ribs. Longitudinal ribs may be present or not.

There shall be at least two rows of transverse ribs equally distributed around the perimeter of the bar. The transverse ribs within each row shall be distributed uniformly over the entire length of the bar, except in the area of marking.

Ribs shall conform to the requirements in Table 3.

Table 3 — Requirements for ribs

	Nominal diameter d mm	Ribs of uniform height	Crescent-shaped ribs
Rib height, a Minimum	All	$0,05d$	$0,065d$
Rib spacing, c Range	$6 \leq d < 10$ $d \geq 10$	$0,5d \leq c \leq 0,7d$ $0,5d \leq c \leq 0,7d$	$0,5d \leq c \leq 1,0d$ $0,5d \leq c \leq 0,8d$
Transverse-rib inclination, β	All	$35^\circ \leq \beta \leq 90^\circ$	$35^\circ \leq \beta \leq 75^\circ$
Transverse-rib flank inclination, α	All	$\alpha \geq 45^\circ$	$\alpha \geq 45^\circ$
Ribless perimeter, Σf_i Maximum	All		$0,25d\pi$

Requirements for rib parameters may be specified by the relative rib area, by agreement between the manufacturer and purchaser. Measurement of rib parameters shall be performed in accordance with ISO 15630-1.

Dimensions defining the rib geometry in Table 3 are shown in Figures 1 to 4.

When longitudinal ribs are present, their height shall not exceed $0,15d$.

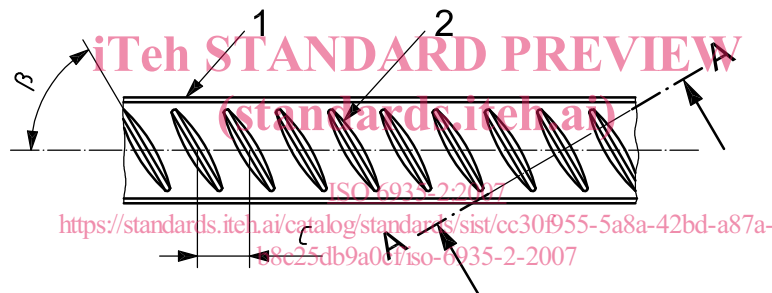

Key

- 1 longitudinal rib
- 2 transverse rib

Figure 1 — Ribbed bar — Definitions of geometry

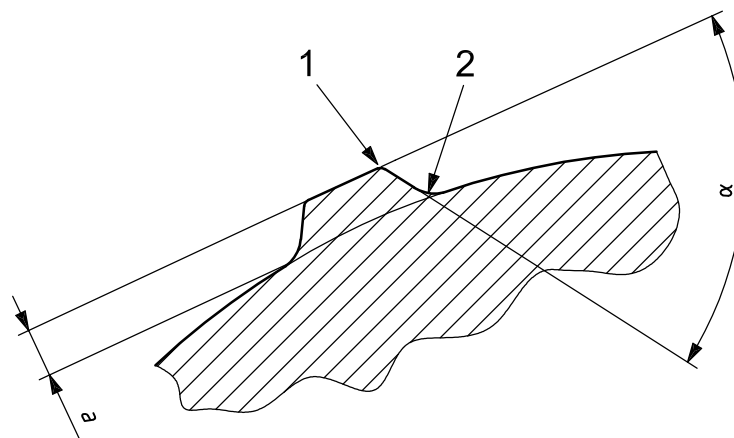

Key

- 1 rib
- 2 rounded transition

Figure 2 — Rib flank inclination, α , and rib height, a — Section A-A from Figure 1

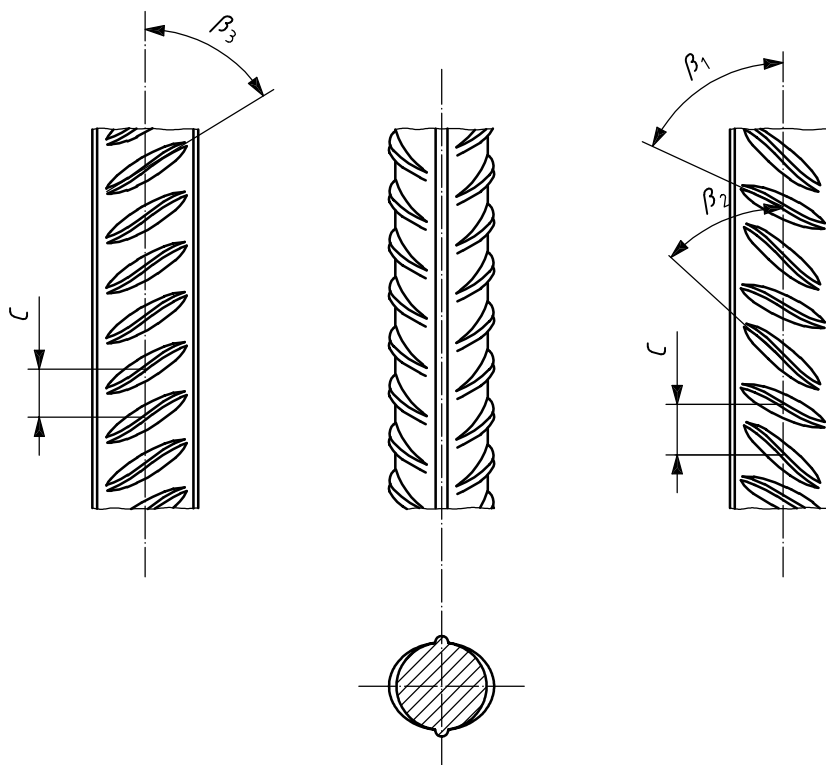

Figure 3 — Example of bar with varying rib inclinations to the longitudinal axis
 (standards.iteh.ai)

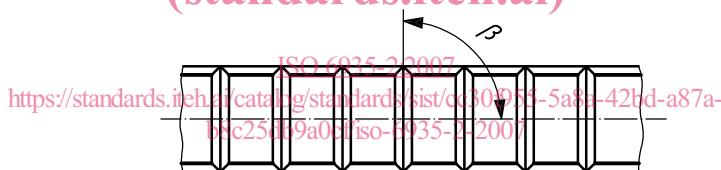

Figure 4 — Example of bar with transverse ribs of uniform height ($\beta = 90^\circ$)

7 Chemical composition

The chemical composition of the steel, as determined by cast analysis, shall conform to Table 4.

The carbon equivalent, CEV, is calculated according to the following formula.

$$\text{CEV} = C + \frac{\text{Mn}}{6} + \frac{(\text{Cr} + \text{V} + \text{Mo})}{5} + \frac{(\text{Cu} + \text{Ni})}{15} \quad (1)$$

where C, Mn, Cr, V, Mo, Cu and Ni are the mass fractions, expressed as percentages, of the respective chemical elements of the steel.

The permissible deviation of the product analysis relative to the cast analysis as specified in Table 4 are given in Table 5.