



Designation: F 833 – 05

Standard Consumer Safety Performance Specification for Carriages and Strollers¹

This standard is issued under the fixed designation F 833; the number immediately following the designation indicates the year of original adoption or, in the case of revision, the year of last revision. A number in parentheses indicates the year of last reappraisal. A superscript epsilon (ϵ) indicates an editorial change since the last revision or reappraisal.

INTRODUCTION

This consumer safety performance specification addresses carriage and stroller incidents that were identified by the U.S. Consumer Product Safety Commission (CPSC).

The CPSC identified injuries to children associated with the following: stability, brakes, restraint systems, latches and folding mechanisms, structural integrity, and deaths due to entrapment in openings of convertible carriage/strollers. By far, the most common injury resulted when a child fell or climbed out of a stroller because the restraint system was not being used. In response to the incidents data developed by the CPSC, this consumer safety performance specification attempts to minimize the previously listed problems. This specification does not cover carriages and strollers that are blatantly misused, although warnings and safety instructions are required to be prominently displayed on or with each carriage or stroller.

NOTE 1—This consumer safety performance specification is not intended to address incidents and injuries resulting from the interaction of other persons with children in carriages or strollers or incidents resulting from unforeseeable abuse or misuse.

This consumer safety performance specification is written within the current state of the art of carriage and stroller technology. It is intended that this specification will be updated whenever substantive information becomes available which necessitates additional requirements or justifies the revision of existing requirements.

1. Scope

1.1 This consumer safety specification establishes safety performance requirements, test methods, and labeling requirements to minimize the hazards to children presented by carriages and strollers as identified in the introduction.

1.2 No carriage or stroller produced after the approval date of this consumer safety performance specification shall, either by label or other means, indicate compliance with this specification unless it conforms to all requirements herein.

1.3 The values stated in inch-pound units are to be regarded as the standard. The SI values given in parentheses are for information only.

1.4 The following precautionary caveat pertains only to the test method portion, Section 7, of this consumer safety specification: *This standard does not purport to address all of the safety concerns, if any, associated with its use. It is the responsibility of the user of this standard to establish appropriate safety and health practices and determine the applicability of regulatory limitations prior to use.*

2. Referenced Documents

2.1 *ASTM Standards*:²

D 3359 Test Methods for Measuring Adhesion by Tape Test

2.2 *Federal Standards*:

16 CFR-1303 Ban of Lead-Containing Paint and Certain Consumer Products Bearing Lead-Containing Paint³

16 CFR-1500 Hazardous Substances Act Regulations³ including sections:

1500.48 Mechanical Requirements for Determining a Sharp Point in Toys or Other Articles Intended for Use by Children Under Eight Years of Age

1500.49 Technical Requirements for Determining a Sharp Metal or Glass Edge in Toys or Other Articles Intended for Use by Children Under Eight Years of Age

1500.50-52 Tests Methods for Simulating Use and Abuse of Toys and Other Articles Intended for Use by Children

16 CFR 1501 Method for Identifying Toys and Other Articles Intended for Use by Children Under Three Years of

¹ This specification is under the jurisdiction of ASTM Committee F15 on Consumer Products and is the direct responsibility of Subcommittee F15.17 on Carriages, Strollers, Walkers, and Stationary Activity Centers.

Current edition approved Jan. 1, 2005. Published January 2005. Originally approved in 1983. Last previous edition approved in 2003 as F 833-03.

² For referenced ASTM standards, visit the ASTM website, www.astm.org, or contact ASTM Customer Service at service@astm.org. For *Annual Book of ASTM Standards* volume information, refer to the standard's Document Summary page on the ASTM website.

³ *Code of Federal Regulations*, available from U.S. Government Printing Office, Washington, DC 20402.



FIG. 1 CAMI Dummy, Mark II

Age Which Present Choking, Aspiration, or Ingestion Hazards Because of Small Parts³

2.3 Other Documents:

CAMI Infant Dummy, Mark II (see Fig. 1)⁴

3. Terminology

3.1 Definitions of Terms Specific to This Standard:

3.1.1 *carriage, n*—wheeled vehicle generally used for the transport of an infant who is generally in a lying down position. The motive power is supplied by a person or persons pushing or pulling on a handle attached to the vehicle. A carriage may be capable of being folded for storage.

3.1.2 *conspicuous, n*—label that is visible, when the unit is in a manufacturer's recommended use position, to a person standing near the unit at any one position around the unit but not necessarily visible from all positions.

3.1.3 *convertible carriage/stroller, n*—wheeled vehicle that is intended to be converted by the owner to be used as either a carriage or a stroller.

3.1.4 *infant, n*—young child who is not capable of sitting unassisted.

3.1.5 *manufacturer's recommended use position, n*—any position that is presented as a normal, allowable, or acceptable configuration for use of the product by the manufacturer in any descriptive or instructional literature. This specifically excludes positions that the manufacturer shows in a like manner in its literature to be unacceptable, unsafe, or not recommended.

3.1.6 *non-paper label, n*—any label material (such as plastic or metal) that either will not tear without the aid of tools or tears leaving a sharply defined edge.

3.1.7 *occupant(s), n*—that individual or those individuals who are in a product that is set up in one of the manufacturer's recommended use positions.

3.1.8 *occupant retention space, n*—space enclosed by the surfaces, for example, side walls or the floor, or both, of a carriage or convertible carriage/stroller that contains the occupant within a carriage or a stroller in the reclined carriage position.

3.1.9 *paper label, n*—any label material that tears without the aid of tools and leaves a fibrous edge.

3.1.10 *reclined carriage position, n*—adjustment position of a convertible carriage/stroller that allows for an interior angle of greater than 150° between the seat surface and the backrest.

3.1.11 *static load, n*—vertically downward force applied by a calibrated force gage or by dead weights.

3.1.12 *stroller, n*—wheeled vehicle for the transport of infants or children generally in a sitting-up or semi-reclined position. The motive power is supplied by a person or persons pushing or pulling on a handle attached to the vehicle. A stroller generally is capable of being folded for storage. Strollers normally are used for children from infancy to 36 months of age.

4. Calibration and Standardization

4.1 All testing shall be conducted on a concrete floor that may be covered with 1/8-in. (3-mm) thick vinyl floor covering, unless test instructs differently.

4.2 The unit shall be completely assembled, unless otherwise noted, in accordance with the manufacturer's instructions.

4.3 No testing shall be conducted within 48 h of manufacturing.

4.4 The product to be tested shall be in a room with an ambient temperature of 73 ± 9°F (23 ± 5°C) for at least 1 h prior to testing. Testing shall then be conducted within this temperature range.

4.5 All testing required by this specification shall be conducted on the same unit.

5. General Requirements

5.1 There shall be no hazardous points or edges as defined by 16 CFR 1500.48 and 16 CFR 1500.49 before and after testing to this consumer safety specification.

5.2 There shall be no small parts as defined by 16 CFR 1501 before testing or liberated as a result of testing to this specification.

5.3 The paint and surface-coating on the product shall comply to 16 CFR 1303.

5.4 Prior to testing, any exposed wood parts shall be smooth and free of splinters.

5.5 *Latching Mechanisms*—Any unit that folds shall have a latching device or other provision in the design that will prevent the unit from unintentional folding when properly placed in the manufacturer's recommended use position. Products with latching devices for prevention of unintentional folding shall be tested in accordance with 7.2. During and upon completion of this test, the unit shall remain latched in its manufacturer's recommended use position.

5.5.1 Strollers that employ hinged links with a geometric over center action (see Fig. 2) to maintain the product in the normal use position shall require two distinct and separate actions on the part of the user to initiate folding of the product.

⁴ Department of Transportation, Federal Aviation Administration, Drawing No. SA-1001.

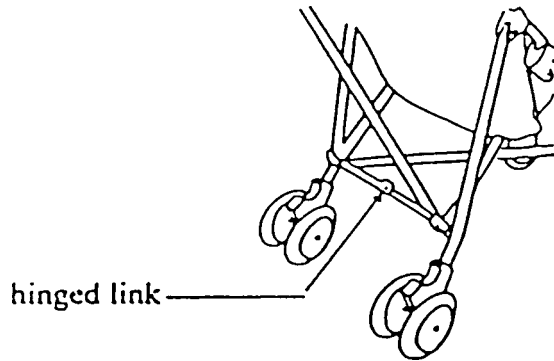

FIG. 2 Stroller With Hinged Link

Such strollers shall require only a single action on the part of the user to secure the stroller in the normal use position.

5.6 *Openings*—Holes or slots that extend entirely through a wall section of any rigid material less than 0.375 in. (9.53 mm) thick and admit a 0.210-in. (5.33-mm) diameter rod shall also admit a 0.375-in. (9.53-mm) diameter rod. Holes or slots that are between 0.210 in. (5.33 mm) and 0.375 in. (9.53 mm) and have a wall thickness less than 0.375 in. (9.53 mm) but are limited in depth to 0.375 in. (9.53 mm) maximum by another rigid surface shall be permissible (see Fig. 3). The product shall be evaluated in all manufacturer’s recommended use positions.

5.7 *Scissoring, Shearing, Pinching*—The unit, when in the manufacturer’s recommended use position, shall be designed and constructed so as to prevent injury to the occupant from

any scissoring, shearing, or pinching when members or components rotate about a common axis or fastening point, slide, pivot, fold, or otherwise move relative to one another. Scissoring, shearing, or pinching that may cause injury shall not be permissible when the edges of the rigid parts admit a probe greater than 0.210-in. (5.33-mm) diameter and less than 0.375-in. (9.53-mm) diameter at any accessible point throughout the range of motion of such parts. This excludes the adjustment of accessory items such as canopies, storage latches, baskets, etc.

5.8 *Exposed Coil Springs*—Any exposed coil spring which is accessible to the occupant, having or capable of generating a space between coils of 0.210 in. (5.33 mm) or greater during static load testing (see 6.2 and 7.3) shall be covered or otherwise designed to prevent injury from entrapment.

5.9 *Labeling*:

5.9.1 Warning labels (whether paper or non-paper) shall be permanent when tested in accordance with 7.8.1-7.8.3.

5.9.2 Warning statements applied directly onto the surface of the product by hot stamping, heat transfer, printing, wood burning, etc. shall be permanent when tested in accordance with 7.8.4.

5.9.3 Non-paper labels shall not liberate small parts when tested in accordance with 7.8.5.

5.10 *Protective Components*—If a child can grasp components between the thumb and forefinger, or teeth, such as caps, sleeves, or plugs used for protection from sharp edges, points, or entrapment of fingers or toes, or if there is at least a 0.040-in. (1.00-mm) gap between the component and its adjacent parent component, such component shall not be removed when tested in accordance with 7.9.

5.11 *Seat Recline Measurement*—Place the back of the stroller in the most reclined position. Place the hinged boards with the hinged edge into the junction of the stroller back and seat (see Fig. 4). Measure the angle between the two boards.

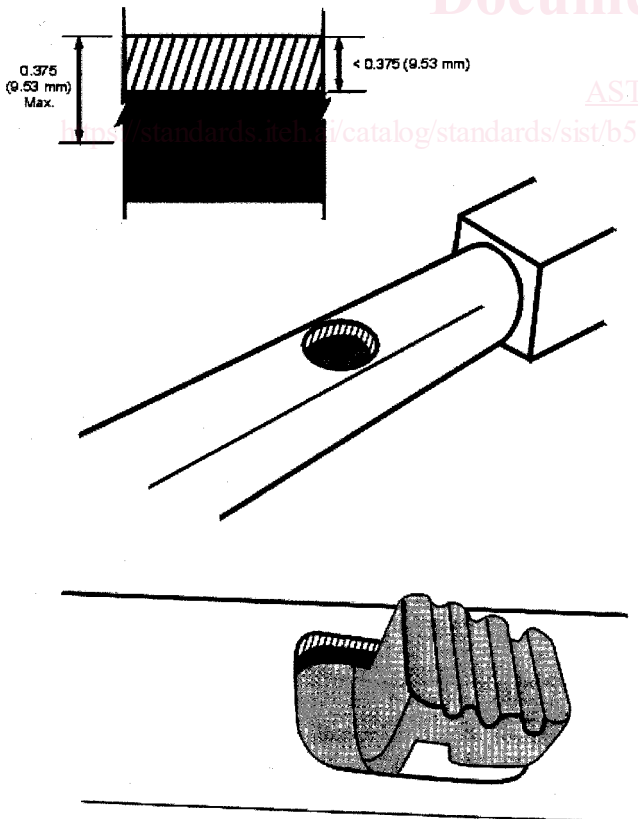

FIG. 3 Opening Example.

6. Performance Requirements

NOTE 1—The forces that are to be applied to the sample in the test methods described in Section 7 of this specification are applied readily by means of a calibrated force gage, or in the case of static load and dynamic load test methods, by dead weights.

6.1 *Brake Requirements*—A braking device shall be provided on the unit. The braking device shall remain engaged and prevent the braked wheel(s) from rotating more than 90° during the test described in 7.6. The brake shall be constructed so that it can not be disengaged by the child within the unit when the child is secured in the unit in accordance with the instructional literature.

6.2 *Static Load*:

6.2.1 A carriage shall support a static load of 50 lbf (222 N) when placed in the approximate center of the area intended to support the infant occupant.

6.2.2 A stroller shall support a static load of 100 lbf (445 N) when placed in the approximate center of the area intended to support the child occupant.

6.2.3 A convertible carriage/stroller shall support a static load appropriate to the configuration in which the unit is erected. All configurations shall be tested.

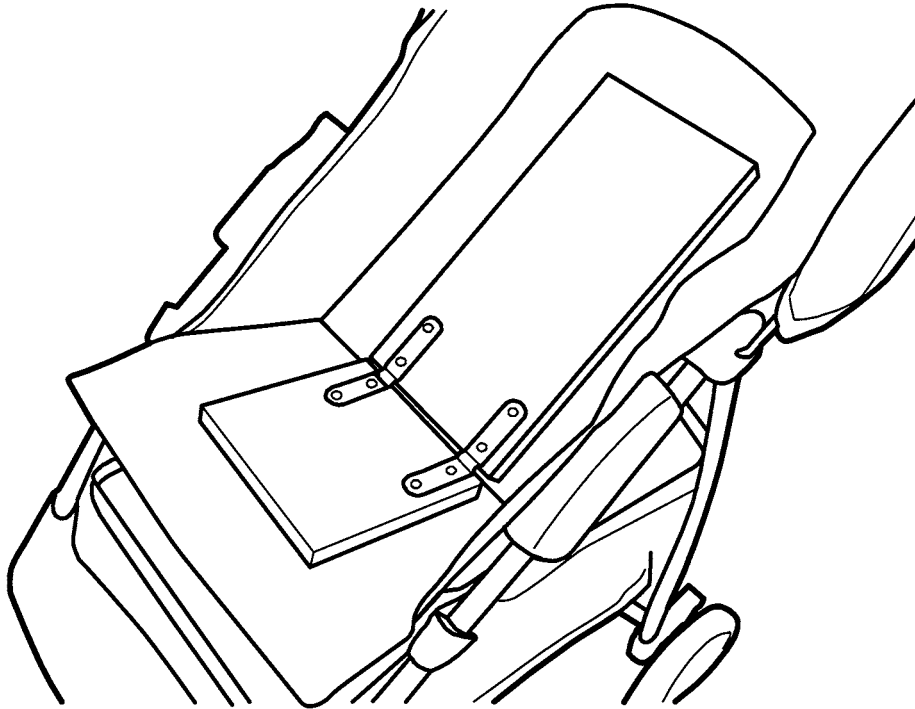

NOTE— $\frac{3}{4}$ in. (19 mm) by 6 in. (150 mm) by 6 in. (150 mm) board hinged to a $\frac{3}{4}$ in. (19 mm) by 6 in. (150 mm) by 12 in. (300 mm) board placed in the junction of the stroller seat.

FIG. 4 Measuring Seat Back Recline

6.2.4 A combination unit of a car seat on a stroller shall support a static load of 50 lbf (222 N) when placed in the approximate center of the area intended to support the occupant.

6.2.5 Test methods shall be performed in accordance with 7.3. At the conclusion of the test method, there shall be no unacceptable conditions as identified within this specification (see Note 2). In cases of multiple occupancy units, a specified test weight shall be applied simultaneously to each occupant position.

NOTE 2—For the purpose of this specification, the unacceptable conditions that might be identified by the static load test methods shall be tip over, collapse of the product or a component of the product, sharp edges or points, and small parts.

6.3 *Stability*—The product shall remain on the appropriate test plane and not tip over when tested in accordance with 7.4. At the end of this test method, the unit shall remain in the manufacturer's recommended-use position on the inclined test plane when tested in accordance with 7.4.1 and on a horizontal test plane when tested in accordance with 7.4.2. In cases of multiple-occupancy units, the specified test weight shall be placed in any occupant seat deemed to be the worst or the most likely to fail. Products that include as original equipment manufacturer-supplied accessories for carrying any type of packages must be tested with these accessories both empty and loaded to the maximum weight specified by the manufacturer, while each available seating position is occupied by the specified test weight.

6.4 *Restraining System*—All products covered by this specification, except carriages designed only for an infant, must have a child restraint system. The manufacturer shall attach the restraint system in such a manner that it will not become detached through normal usage. The restraint system shall include both waist and crotch restraint. The crotch resistant shall be designed such that its use is mandatory when the restraint system is in use.

6.4.1 *Carriage*—No restraining system is required if the carriage is intended to be used for an infant only. Carriages with accessory sit-up backs or other items indicating intent to be used for children developed beyond infancy must have a restraining system (see 6.4.4).

6.4.2 *Stroller*—A restraining system shall be provided pre-assembled by the manufacturer to a component of the stroller.

6.4.3 *Convertible Carriage/Stroller*—A restraining system shall be provided on each convertible carriage/stroller that will function as though the unit is specifically a carriage (see 6.4.1) or stroller (see 6.4.2).

6.4.4 *Restraining System*—Test methods for all restraining systems shall be in accordance with 7.5. The closing mechanisms shall not part or slip more than 1 in. (25 mm). The anchorages shall not separate from their attachment points. At the end of the tests, the CAMI dummy shall not be released fully. When tested in accordance with 7.5.2.8, the restraint system (see Fig. 5 for Point C) shall not move more than 2 in. (51 mm).

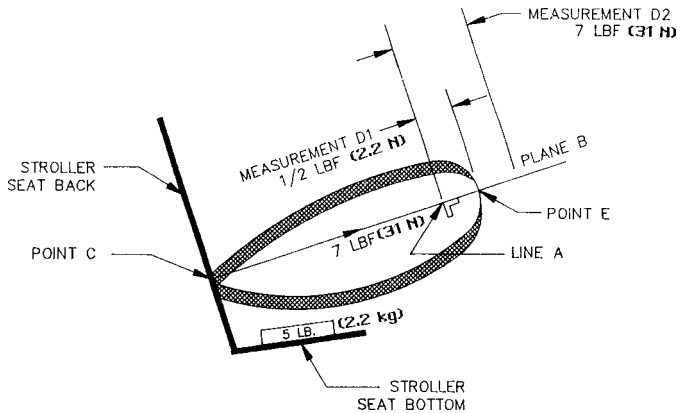

FIG. 5 Restraint System Setup

6.4.5 *Location of Restraining System*—When tested in accordance with 7.5.3, the restraining system shall meet the following requirements.

6.4.5.1 The anchor points of the waist restraint shall be between the 2-in. (50-mm) line and the 5-in. (127-mm) line on the test cylinder when tested in accordance with 7.5.3.3.

6.4.5.2 A 1-in. (25-mm) diameter probe shall not freely pass through any gap between the waist restraint and the test cylinder when tested in accordance with 7.5.3.4.

6.4.5.3 The location of the crotch anchor shall not be in front of the test cylinder when tested in accordance with 7.5.3.5.

6.4.5.4 The point on the lower edge of the waist strap shall be between the 4.5-in. (114-mm) line and the 7.5-in. (190-mm) line on the test cylinder when tested in accordance with 7.5.3.6.

6.5 *Occupant Retention*—Carriages or seating locations of convertible carriage/strollers with a reclined carriage position(s) shall have a wall(s) surrounding all sides above the floor of the occupant retention space. The enclosure shall not allow the complete passage of the test probe shown in Fig. 6 through

any completely bounded external openings (any holes) below the top edge of the occupant retention space when tested in accordance with 7.7.

6.5.1 Products with a reclined carriage position(s) must have a nondetachable feature to enable them to conform to the requirement in 6.5 unless the product only can be adjusted to any reclined carriage position when a detachable device is attached.

6.5.1.1 Nondetachable denotes that the occupant retention assembly cannot be separated or removed from the product without damaging it or be removed without the aid of tools.

6.6 *Combination Unit of a Car Seat on a Stroller*—The combined unit shall conform to the requirements of 2.2, 5.5 in accordance with 7.2, 6.1 in accordance with 7.6, 6.2.4 in accordance with 7.3.2, 6.3 in accordance with 7.4.1, 7.10, and 9.1 in all manufacturer’s recommended use positions. When testing the combination unit according to 7.10 (16 CFR 1500.52 (b) (4) (iii)), the unit shall neither have any broken parts nor allow the car seat to completely separate from the stroller.

7. Test Methods

7.1 If during the course of conducting the test methods in this safety specification, a test model suffers any permanent deformation or damage, an additional test model of the same model shall be used for the remainder of the test methods.

7.2 *Latching Mechanisms for Prevention of Unintentional Folding:*

7.2.1 Erect the product in accordance with the manufacturer’s instructions, and gradually place a 5-lb (2.3-kg) weight (similar to a 5-lb bag of sugar) in the center of the supporting surface.

7.2.2 Place the product in the manufacturer’s recommended use position so that the normal folding motion is not impeded.

7.2.3 Apply a force of 45 lbf (200 N) at the location normally associated with the folding action and in the direction

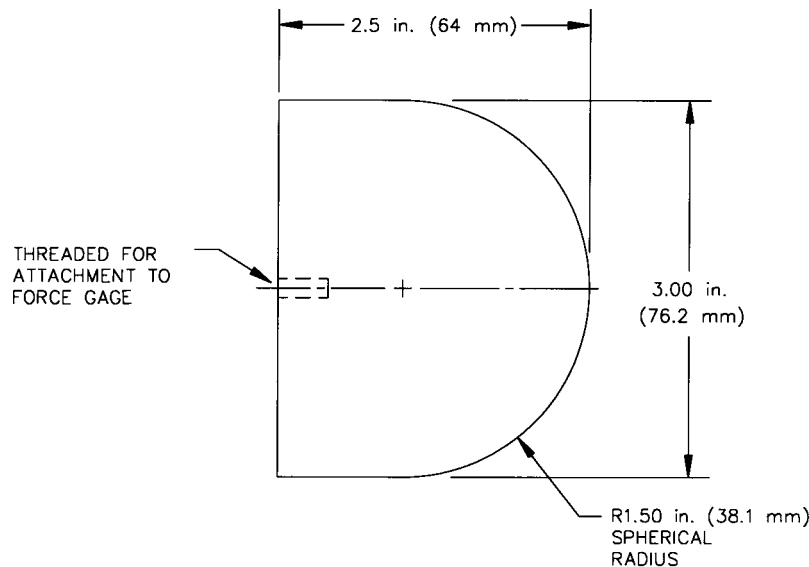

MATERIAL: SMOOTH FINISH PLASTIC OR METAL
FIG. 6 Occupant Retention Probe

normally associated with folding the product in accordance with the manufacturer’s instructions. Gradually apply the force within 5 s and maintain for an additional 10 s.

NOTE 3—Do not apply this force on latching or unlatching means itself.

7.2.4 Repeat 7.2.3 for a total of 5 times within 2 min.

7.2.5 Fold the unit in accordance with the manufacturer’s instructions and repeat 7.2.1, 7.2.2, and 7.2.3 one additional time.

7.3 Static Load Test Method:

7.3.1 Place the product in the manufacturer’s recommended use position.

7.3.2 Place the specified weight from 6.2 upon a 6 by 6-in. (150 by 150-mm) wood block 3/4 in. (19 mm) thick in the unit at the location called for in 6.2. If the unit has a hammock-type seat, use a standard 6-in. weld cap as identified in Fig. 7 instead of the specified wood block upon which to place the test weight. Make allowances for the mass of the weld cap. Gradually apply the weight within 5 s and maintain for an additional 60 s.

7.3.3 Place a 50-lb (22.7-kg) weight upon the center of any step or footrest and distribute it upon a 3 by 6-in. (75 by 150-mm) wood block 3/4 in. (19 mm) thick. If the step or foot rest is adjustable, the test method should be done only in the lowest use position. Gradually apply the weight within 5 s and maintain for an additional 60 s.

7.4 Stability Test Method:

7.4.1 Stability with Occupant(s) in the Product:

7.4.1.1 Place the product in the manufacturer’s use position with all wheels on a 12° inclined plane. If the test model has an adjustable back rest, test in the most upright, recline, and carriage use positions.

7.4.1.2 In the upright and recline (an interior angle of 150° or less as measured in accordance with 5.11 between the seat surface and the backrest) use positions, place a CAMI Dummy, Mark II (see Fig. 1) in the carriage or stroller, and secure the restraint system in accordance with the manufacturer’s instruction.

7.4.1.3 For the carriage use position, an interior angle of greater than 150° as measured in accordance with 5.11 between the seat surface and the backrest, place the CAMI Dummy, Mark II (see Fig. 1) with the dummy’s head against the rear surface of the occupant retention space and the handle in the stroller mode.

7.4.1.4 Place a stop on the plane against the wheels in a manner that will prevent the carriage or stroller from moving on the plane but will not prevent it from tipping.

7.4.1.5 Position the stroller or carriage on the plane in all orientations that present maximum tendency for the unstable condition to exist.

7.4.2 Front Stability (Child Climbing in) for Stroller or Convertible Carriage/Stroller in Stroller Use Only:

7.4.2.1 Place the unit in the manufacturer’s recommended use position with all wheels on a flat horizontal plane. With no added weight in the seating compartment, place the foot rest or step, or both, in the lowest use position, which is the normal use position.

7.4.2.2 Apply a force of 40 lbf (178 N) vertically downward at a position on the centerline not to exceed 1 in. (25 mm) from the front edge of the forward most horizontal member, with a pad not exceeding 2 in. (50 mm) in diameter.

7.4.2.3 Repeat 7.4.2.2 to any horizontal member on the left and right of the centerline, applying the vertically downward force on the location most likely to cause the unit to tip over.

7.5 Restraining System Integrity and Occupant Retention Test Methods:

7.5.1 Restraining System Integrity Test Method:

7.5.1.1 Secure the test model so that it cannot move vertically or horizontally.

7.5.1.2 Apply a force of 45 lbf (200 N) to a single attachment point of the restraint system in the normal use direction(s) that stress would be applied to that attachment. Gradually apply the force within 5 s and maintain for an additional 10 s.

7.5.1.3 Repeat 7.5.1.2 for a total of five times with a maximum interval of 5 s between tests.

7.5.1.4 Repeat 7.5.1.2 and 7.5.1.3 for each attachment point of the restraint system and fastening device.

7.5.2 Restraining System Occupant Retention Test Method:

7.5.2.1 If the test model has an adjustable back rest, place it in the most upright use position. Place a CAMI Infant Dummy, Mark II (see Fig. 1) in the test unit with the restraining system fastened in accordance with the manufacturer’s instructions. Tighten the restraining system in such a manner that a force of 2 lbf (9 N) or less will provide at least a 1/4-in. (6-mm) space between the restraint system and the dummy. The webbing tension pull device shown (Fig. 8) is required to determine proper restraint system fit. Perform the following tests without readjusting the restraint system.

7.5.2.2 Apply a pull force of 45 lbf (200 N) horizontally on the approximate centerline of either leg of the dummy (at the ankle). Gradually apply the force within 5 s and maintain for an additional 10 s.

7.5.2.3 Repeat 7.5.2.2 for a total of five times with a maximum interval of 5 s between tests.

7.5.2.4 Release the test unit from its attachment to the test plane (7.5.1).

7.5.2.5 Reposition the CAMI Infant Dummy, Mark II (Fig. 1) into the seated position without adjusting the restraint system.

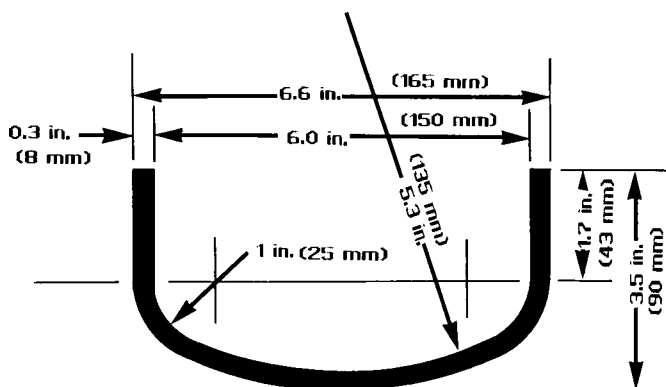

FIG. 7 Weld Cap