



# SLOVENSKI STANDARD SIST EN ISO 1182:2002

01-september-2002

---

**Preskusi odziva gradbenih proizvodov na ogenj - Preskus negorljivosti (ISO 1182:2002)**

Reaction to fire tests for building products - Non-combustibility test (ISO 1182:2002)

Prüfungen zum Brandverhalten von Bauprodukten - Nichtbrennbarkeitsprüfung (ISO 1182:2002)

Essais de réaction au feu des produits de construction - Essai d'incombustibilité (ISO 1182:2002)

**iTeh STANDARD PREVIEW**

(standards.iteh.ai)

[SIST EN ISO 1182:2002](https://standards.iteh.ai/catalog/standards/sist/cb7f135d-0ac2-41cc-b21e-46c161053a87/sist-en-iso-1182-2002)

**Ta slovenski standard je istoveten z: EN ISO 1182:2002**

---

**ICS:**

13.220.50	Požarna odpornost gradbenih materialov in elementov	Fire-resistance of building materials and elements
-----------	---	--

**SIST EN ISO 1182:2002**

**en**

**iTeh STANDARD PREVIEW**  
**(standards.iteh.ai)**

SIST EN ISO 1182:2002

<https://standards.iteh.ai/catalog/standards/sist/cbff35d-0ac2-41cc-b21e-46e161058a87/sist-en-iso-1182-2002>

EUROPEAN STANDARD  
NORME EUROPÉENNE  
EUROPÄISCHE NORM

**EN ISO 1182**

February 2002

ICS 13.220.50

English version

## Reaction to fire tests for building products - Non-combustibility test (ISO 1182:2002)

Essais de réaction au feu des produits de construction -  
Essai d'incombustibilité (ISO 1182:2002)

Prüfungen zum Brandverhalten von Bauprodukten -  
Nichtbrennbarkeitsprüfung (ISO 1182:2002)

This European Standard was approved by CEN on 3 May 2001.

CEN members are bound to comply with the CEN/CENELEC Internal Regulations which stipulate the conditions for giving this European Standard the status of a national standard without any alteration. Up-to-date lists and bibliographical references concerning such national standards may be obtained on application to the Management Centre or to any CEN member.

This European Standard exists in three official versions (English, French, German). A version in any other language made by translation under the responsibility of a CEN member into its own language and notified to the Management Centre has the same status as the official versions.

CEN members are the national standards bodies of Austria, Belgium, Czech Republic, Denmark, Finland, France, Germany, Greece, Iceland, Ireland, Italy, Luxembourg, Malta, Netherlands, Norway, Portugal, Spain, Sweden, Switzerland and United Kingdom.

SIST EN ISO 1182:2002

<https://standards.iteh.ai/catalog/standards/sist/cbff35d-0ac2-41cc-b21e-46e161058a87/sist-en-iso-1182-2002>



EUROPEAN COMMITTEE FOR STANDARDIZATION  
COMITÉ EUROPÉEN DE NORMALISATION  
EUROPÄISCHES KOMITEE FÜR NORMUNG

Management Centre: rue de Stassart, 36 B-1050 Brussels

## Contents

	page
Foreword .....	3
Introduction .....	4
1 Scope .....	5
2 Normative references .....	5
3 Terms and definitions .....	5
4 Test apparatus .....	6
5 Test specimen .....	12
6 Conditioning .....	13
7 Test procedure .....	13
8 Expression of results .....	22
9 Test report .....	22
Annex A (informative) Precision of test method .....	24
Annex B (informative) Typical designs of test apparatus .....	27
Annex C (normative) Thermocouples for additional measurements .....	30
Annex D (informative) Temperature recording .....	32

iTech STANDARD PREVIEW  
 (standards.itech.ai)  
 SIST EN ISO 1182:2002  
<https://standards.itech.ai/catalog/standards/sist/cbffd35d-0ac2-41cc-b21e-46e161058a87/sist-en-iso-1182-2002>

## Foreword

The text of EN ISO 1182:2002 has been prepared by Technical Committee CEN/TC 127 “Fire safety in buildings”, the secretariat of which is held by BSI in collaboration with Technical Committee ISO/TC 92 “Fire safety”.

This European Standard shall be given the status of a national standard, either by publication of an identical text or by endorsement, at the latest by August 2002, and conflicting national standards shall be withdrawn at the latest by December 2003.

Annexes A, B and D are informative. Annex C is normative.

According to the CEN/CENELEC Internal Regulations, the national standards organizations of the following countries are bound to implement this European Standard: Austria, Belgium, the Czech Republic, Denmark, Finland, France, Germany, Greece, Iceland, Ireland, Italy, Luxembourg, Malta, Netherlands, Norway, Portugal, Spain, Sweden, Switzerland and the United Kingdom.

## iTeh STANDARD PREVIEW (standards.iteh.ai)

[SIST EN ISO 1182:2002](https://standards.iteh.ai/catalog/standards/sist/cbff35d-0ac2-41cc-b21e-46e161058a87/sist-en-iso-1182-2002)

<https://standards.iteh.ai/catalog/standards/sist/cbff35d-0ac2-41cc-b21e-46e161058a87/sist-en-iso-1182-2002>

**EN 1182:2002 (E)****Introduction**

This fire test has been developed for use by those responsible for selection of construction products which, whilst not completely inert, produce only a very limited amount of heat and flame when exposed to temperatures of approximately 750 °C.

The limitation of the field of application to testing homogeneous products and substantial components of non-homogeneous products was introduced because of problems in defining specifications for the specimens. The design of the specimen of non-homogeneous products strongly influences the test results, which is the reason why non-homogeneous products cannot be tested to this standard.

**Safety warning**

The attention of all persons concerned with managing and carrying out this test is drawn to the fact that fire testing may be hazardous and that there is a possibility that toxic and/or harmful smoke and gases may be evolved during the test. Operational hazards may also arise during the testing of specimens and the disposal of test residues.

An assessment of all potential hazards and risks to health should be made and safety precautions should be identified and provided. Written safety instructions should be issued. Appropriate training should be given to relevant personnel. Laboratory personnel should ensure that they follow written safety instructions at all times.

**(standards.iteh.ai)**

[SIST EN ISO 1182:2002](https://standards.iteh.ai/catalog/standards/sist/cbff35d-0ac2-41cc-b21e-46e161058a87/sist-en-iso-1182-2002)

<https://standards.iteh.ai/catalog/standards/sist/cbff35d-0ac2-41cc-b21e-46e161058a87/sist-en-iso-1182-2002>

## 1 Scope

This European Standard specifies a method of test for determining the non-combustibility performance, under specified conditions, of homogeneous building products and substantial components of non-homogeneous building products.

Information on the precision of the test method is given in annex A.

## 2 Normative references

This European Standard incorporates by dated or undated reference, provisions from other publications. These normative references are cited at appropriate places in the text, and the publications are listed hereafter. For dated references subsequent amendments to or revisions of, any of these publications apply to this European Standard only when incorporated in it by amendment or revision. For undated references the latest edition of the publication referred to applies (including amendments).

EN 13238, *Reaction to fire tests for building products — Conditioning procedures and general rules for selection of substrates*.

EN ISO 13943, *Fire safety — Vocabulary* (ISO 13943:1999).

EN 60584-2, *Thermocouples — Part 2: Tolerances* (IEC 60584-2:1982+A1:1989).

iTeh STANDARD PREVIEW  
(standards.iteh.ai)

## 3 Terms and definitions

For the purpose of this European Standard, the terms and definitions given in EN ISO 13943, together with the following, apply:

[SIST EN ISO 1182:2002  
https://standards.iteh.ai/catalog/standards/sist/cbffd35d-0ac2-41cc-b21e-46e161058a87/sist-en-iso-1182-2002](https://standards.iteh.ai/catalog/standards/sist/cbffd35d-0ac2-41cc-b21e-46e161058a87/sist-en-iso-1182-2002)

### 3.1

#### **product**

material, element or component about which information is required

### 3.2

#### **material**

a single basic substance or uniformly dispersed mixture of substances e.g. metal, stone, timber, concrete, mineral wool with uniformly dispersed binder, polymers

### 3.3

#### **loose fill material**

material without any physical shape

### 3.4

#### **homogeneous product**

a product, consisting of a single material, having uniform density and composition throughout the product

### 3.5

#### **non-homogeneous product**

a product that does not satisfy the requirements of a homogeneous product. It is a product composed of more than one component, substantial and/or non-substantial

## EN 1182:2002 (E)

## 3.6

**substantial component**

a material that constitutes a significant part of a non-homogeneous product. A layer with a mass/unit area  $\geq 1,0 \text{ kg/m}^2$  or a thickness  $\geq 1,0 \text{ mm}$  is considered to be a substantial component

## 4 Test apparatus

## 4.1 General

4.1.1 The test apparatus shall be capable of creating the conditions specified in 7.1. A typical design of furnace is given in annex B; other designs of furnace may be used.

4.1.2 All dimensions given in the description of the test apparatus are nominal values, unless tolerances are specified.

4.1.3 The apparatus shall consist of a furnace comprising essentially a refractory tube surrounded by a heating coil and enclosed in an insulated surround. A cone-shaped airflow stabilizer shall be attached to the base of the furnace and a draught shield to its top.

4.1.4 The furnace shall be mounted on a stand and shall be equipped with a specimen holder and a device for inserting the specimen-holder into the furnace tube.

4.1.5 Thermocouples, as specified in 4.4, shall be provided for measuring the furnace temperature and the furnace wall temperature, annex C gives details of additional thermocouples to be used if the specimen surface temperature and the specimen centre temperature are required. The thermal sensor, as specified in 4.5, shall be provided for measuring the furnace temperature along its central axis.

## 4.2 Furnace, stand and draught shield

4.2.1 The furnace tube shall be made of an alumina refractory material as specified in Table 1, of density  $(2\,800 \pm 300) \text{ kg/m}^3$  and shall be  $(150 \pm 1) \text{ mm}$  high with an internal diameter of  $(75 \pm 1) \text{ mm}$  and a wall thickness of  $(10 \pm 1) \text{ mm}$ .

Table 1 — Composition of the furnace tube refractory material

Material	Composition % (kg/kg mass)
Alumina ( $\text{Al}_2\text{O}_3$ )	> 89
Silica and alumina ( $\text{SiO}_2$ , $\text{Al}_2\text{O}_3$ )	> 98
Ferric oxide ( $\text{Fe}_2\text{O}$ )	< 0,45
Titanium dioxide ( $\text{TiO}_2$ )	< 0,25
Manganese oxide ( $\text{Mn}_3\text{O}_4$ )	< 0,1
Other trace oxides (sodium, potassium, calcium and magnesium oxides)	The balance

4.2.2 The furnace tube shall be fitted in the centre of a surround made of insulating material 150 mm in height and of 10 mm wall thickness, and fitted with top and bottom plates recessed internally to locate the ends of the furnace tube. The annular space between the tubes shall be filled with a suitable insulating material. A typical example is given in annex B.



**4.2.3** To the underside of the furnace shall be attached an open-ended cone-shaped air flow stabilizer 500 mm in length, and reducing uniformly from  $(75 \pm 1)$  mm internal diameter at the top to  $(10 \pm 0,5)$  mm internal diameter at the bottom. The stabilizer shall be manufactured from 1 mm thick sheet steel, with a smooth finish on the inside. The joint between the stabilizer and the furnace shall be a close, airtight fit, with a smooth finish internally. The upper half of the stabilizer shall be insulated externally with a suitable insulating material. A typical example is given in annex B.

**4.2.4** A draught shield made of the same material as the stabilizer cone shall be provided at the top of the furnace. It shall be 50 mm high and have an internal diameter of  $(75 \pm 1)$  mm. The draught shield and its joint with the top of the furnace shall have a smooth finish internally, and the exterior shall be insulated with a suitable insulating material. A typical example is given in annex B.

**4.2.5** The assembly of the furnace, stabilizer cone and draught shield shall be mounted on a firm horizontal stand which shall be provided with a base and draught screen attached to the stand to reduce draughts around the bottom of the stabilizer cone. The draught screen shall be 550 mm high and the bottom of the stabilizer cone shall be 250 mm above the base plate.

### 4.3 Specimen holder and insertion device

**4.3.1** The specimen holder shall be as specified in Figure 1, and shall be made of nickel/chromium or heat-resisting steel wire. A fine metal gauze tray of heat-resisting steel shall be placed in the bottom of the holder. The mass of the holder shall be  $(15 \pm 2)$  g.

**4.3.2** The specimen holder shall be capable of being suspended from the lower end of a tube of stainless steel having an outside diameter of 6 mm and a bore of 4 mm.

**4.3.3** The specimen holder shall be provided with a suitable insertion device for lowering it precisely down the axis of the furnace tube without shock, so that the geometric centre of the specimen is located rigidly at the geometric centre of the furnace during the test. The insertion device shall consist of a metallic sliding rod moving freely within a vertical guide fitted to the side of the furnace.

<https://standards.iteh.ai/catalog/standards/sist/cbffd35d-0ac2-41cc-b21e-46e161058a87/sist-en-iso-1182-2002>

Dimensions in millimetres

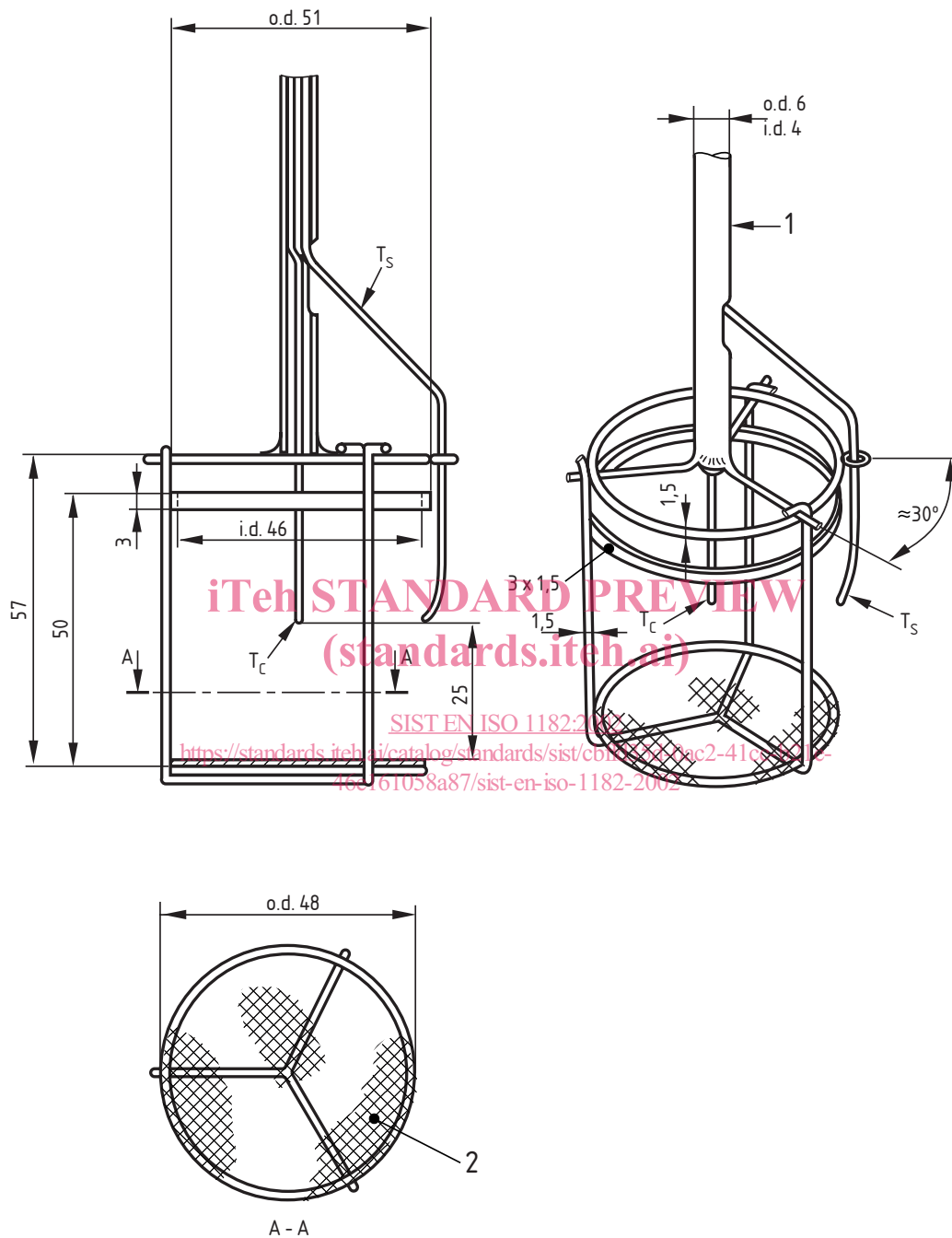
**Key**

- 1 Stainless steel tube  
 2 Aperture mesh 0,9 mm diameter of wire 0,4 mm

- $T_c$  Specimen centre thermocouple  
 $T_s$  Specimen surface thermocouple

**Note** - use of  $T_c$  and  $T_s$  is optional

**Figure 1 — Specimen holder**

**4.3.4** The specimen holder for loose fill materials shall be cylindrical and of the same outer dimensions as the specimen (see 5.1) and made of a fine metal wire gauze of heat resisting steel similar to the wire gauze used at the bottom of the normal holder specified in 4.3.1. The specimen holder shall have an open end at the top. The mass of the holder shall not exceed 30 g.

#### **4.4 Thermocouples**

**4.4.1** Thermocouples with a wire diameter of 0,3 mm and an outer diameter of 1,5 mm shall be used. The hot junction shall be insulated and not earthed. The thermocouples shall be of either type K or type N. They shall be of tolerance class 1 in accordance with EN 60584-2. The sheathing material shall be either stainless steel or a nickel based alloy.

**4.4.2** All new thermocouples shall be artificially aged before use to reduce reflectivity.

**4.4.3** The furnace thermocouple shall be located with its hot junction ( $10 \pm 0,5$ ) mm from the tube wall and at a height corresponding to the geometric centre of the furnace tube (see Figure 2). The position of the thermocouple may be set using the locating guide illustrated in Figure 3, and the correct position shall be maintained with the help of a guide attached to the draught shield.

**4.4.4** Details of any additional thermocouples required and their positioning are given in annex C.

#### **4.5 Thermal sensor**

The thermal sensor shall be made of a thermocouple of the type specified in 4.4.1 and 4.4.2, brazed to a copper cylinder of diameter ( $10 \pm 0,2$ ) mm and height ( $15 \pm 0,2$ ) mm.

#### **4.6 Mirror**

To facilitate observation of sustained flaming and for the safety of the operators, it is advisable to provide a mirror above the apparatus, positioned so that it will not affect the test.

A mirror 300 mm square, at an angle of  $30^\circ$  to the horizontal, 1 m above the furnace has been found suitable.

#### **4.7 Balance**

A balance with an accuracy of 0,01 g is required.

#### **4.8 Voltage stabilizer**

This shall be a single-phase automatic voltage stabilizer with a rating of not less than 1,5 kVA.

It shall be capable of maintaining the accuracy of the output voltage within  $\pm 1\%$  of the rated value from zero to full load.

#### **4.9 Variable transformer**

This shall be capable of handling at least 1,5 kVA and of regulating the voltage output from zero to a maximum value equal to that of the input voltage. The voltage output shall vary linearly over the range.

#### **4.10 Electrical input monitor**

An ammeter, and voltmeter or wattmeter, shall be provided to enable rapid setting of the furnace to approximately the operating temperature. Any of these instruments shall be capable of measuring the levels of electrical power specified in 7.2.3.

Dimensions in millimetres

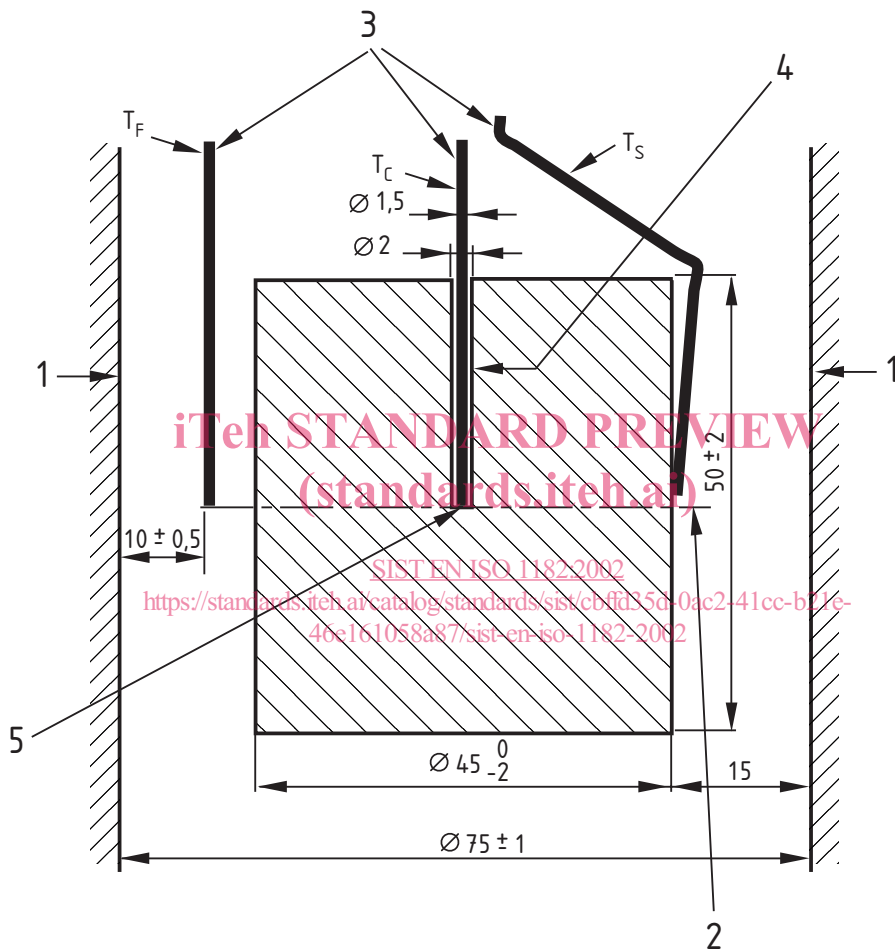
**Key**

- |   |   |       |                               |
|---|---|-------|-------------------------------|
| 1 | Furnace wall                              | $T_F$ | Furnace thermocouple          |
| 2 | Mid-height of constant temperature zone   | $T_C$ | Specimen centre thermocouple  |
| 3 | Sheathed thermocouples                    | $T_S$ | Specimen surface thermocouple |
| 4 | 2 mm diameter hole                        |       |                               |
| 5 | Contact between thermocouple and material |       |                               |
- NOTE Use of  $T_C$  and  $T_S$  is optional.

**Figure 2 — Relative position of furnace, specimen and thermocouple**