**Containers and accessories for
pharmaceutical preparations —**

**Part 4:
Tablet glass bottles**

Réipients et accessoires pour préparations pharmaceutiques —

Partie 4: Piluliers en verre

iTeh STANDARD PREVIEW
(standards.iteh.ai)

[ISO 11418-4:2005](https://standards.iteh.ai/catalog/standards/sist/cc8cc017-99aa-4b9c-a2e7-7658475954f8/iso-11418-4-2005)

<https://standards.iteh.ai/catalog/standards/sist/cc8cc017-99aa-4b9c-a2e7-7658475954f8/iso-11418-4-2005>



PDF disclaimer

This PDF file may contain embedded typefaces. In accordance with Adobe's licensing policy, this file may be printed or viewed but shall not be edited unless the typefaces which are embedded are licensed to and installed on the computer performing the editing. In downloading this file, parties accept therein the responsibility of not infringing Adobe's licensing policy. The ISO Central Secretariat accepts no liability in this area.

Adobe is a trademark of Adobe Systems Incorporated.

Details of the software products used to create this PDF file can be found in the General Info relative to the file; the PDF-creation parameters were optimized for printing. Every care has been taken to ensure that the file is suitable for use by ISO member bodies. In the unlikely event that a problem relating to it is found, please inform the Central Secretariat at the address given below.

iTeh STANDARD PREVIEW
(standards.iteh.ai)

[ISO 11418-4:2005](https://standards.iteh.ai/catalog/standards/sist/cc8cc017-99aa-4b9c-a2e7-7658475954f8/iso-11418-4-2005)

<https://standards.iteh.ai/catalog/standards/sist/cc8cc017-99aa-4b9c-a2e7-7658475954f8/iso-11418-4-2005>

© ISO 2005

All rights reserved. Unless otherwise specified, no part of this publication may be reproduced or utilized in any form or by any means, electronic or mechanical, including photocopying and microfilm, without permission in writing from either ISO at the address below or ISO's member body in the country of the requester.

ISO copyright office
Case postale 56 • CH-1211 Geneva 20
Tel. + 41 22 749 01 11
Fax + 41 22 749 09 47
E-mail copyright@iso.org
Web www.iso.org

Published in Switzerland

Foreword

ISO (the International Organization for Standardization) is a worldwide federation of national standards bodies (ISO member bodies). The work of preparing International Standards is normally carried out through ISO technical committees. Each member body interested in a subject for which a technical committee has been established has the right to be represented on that committee. International organizations, governmental and non-governmental, in liaison with ISO, also take part in the work. ISO collaborates closely with the International Electrotechnical Commission (IEC) on all matters of electrotechnical standardization.

International Standards are drafted in accordance with the rules given in the ISO/IEC Directives, Part 2.

The main task of technical committees is to prepare International Standards. Draft International Standards adopted by the technical committees are circulated to the member bodies for voting. Publication as an International Standard requires approval by at least 75 % of the member bodies casting a vote.

Attention is drawn to the possibility that some of the elements of this document may be the subject of patent rights. ISO shall not be held responsible for identifying any or all such patent rights.

ISO 11418-4 was prepared by Technical Committee ISO/TC 76, *Transfusion, infusion and injection equipment for medical and pharmaceutical use*.

This second edition cancels and replaces the first edition (ISO 11418-4:1996), which has been technically revised.

ISO 11418 consists of the following parts, under the general title *Containers and accessories for pharmaceutical preparations*:

- iTeh STANDARD PREVIEW**
(standards.iteh.ai)
- <https://standards.iteh.ai/catalog/standards/sist/cc8cc017-99aa-4b9c-a2e7-7658475954f8/iso-11418-4-2005>
- Part 1: *Drop-dispensing glass bottles*
 - Part 2: *Screw-neck glass bottles for syrups*
 - Part 3: *Screw-neck glass bottles (veral) for solid and liquid dosage forms*
 - Part 4: *Tablet glass bottles*
 - Part 5: *Dropper assemblies*
 - Part 7: *Screw-neck vials made of glass tubing for liquid dosage forms*

iTeh STANDARD PREVIEW
(standards.iteh.ai)

[ISO 11418-4:2005](#)

<https://standards.iteh.ai/catalog/standards/sist/cc8cc017-99aa-4b9c-a2e7-7658475954f8/iso-11418-4-2005>

Containers and accessories for pharmaceutical preparations —

Part 4: Tablet glass bottles

1 Scope

This part of ISO 11418 specifies the design, dimensions, material and requirements of tablet glass bottles. Tablet glass bottles are applicable to primary packs used in direct contact with a drug.

This part of ISO 11418 is applicable to tablet glass bottles used in pharmacy. Together with the corresponding closure systems, they serve for packaging of pharmaceutical preparations in solid and liquid dosage forms which are not intended for parenteral use.

NOTE The potency, purity, stability and safety of a drug during its manufacture and storage can be strongly affected by the nature and performance of the primary pack.

2 Normative references

The following referenced documents are indispensable for the application of this document. For dated references, only the edition cited applies. For undated references, the latest edition of the referenced document (including any amendments) applies.

ISO 719:1985, *Glass — Hydrolytic resistance of glass grains at 98 °C — Method of test and classification*

ISO 720:1985, *Glass — Hydrolytic resistance of glass grains at 121 °C — Method of test and classification*

ISO 1101:2004, *Geometrical Product Specifications (GPS) — Geometrical tolerancing — Tolerances of form, orientation, location and run-out*

ISO 4802-1:1988, *Glassware — Hydrolytic resistance of the interior surfaces of glass containers — Part 1: Determination by titration method and classification*

ISO 4802-2:1988, *Glassware — Hydrolytic resistance of the interior surfaces of glass containers — Part 2: Determination by flame spectrometry and classification*

ISO 7459:2004, *Glass containers — Thermal shock resistance and thermal shock endurance — Test methods*

ISO 8113:2004, *Glass containers — Resistance to vertical load — Test method*

3 Dimensions and designation

3.1 Dimensions

The dimensions of tablet glass bottles shall be as shown in Figure 1 and as given in Table 1.

Tolerancing of form, orientation, location and run-out not specified in this part of ISO 11418 shall be in accordance with ISO 1101.

3.2 Designation

Tablet glass bottles for pharmaceutical preparations shall be designated by a reference to this part of ISO 11418, followed by the nominal volume and the colour of the glass.

EXAMPLE A tablet glass bottle of nominal volume 60 ml, made of colourless glass (cl) of hydrolytic resistance container class ISO 4802 – HC 3, in accordance with this part of ISO 11418 is designated as follows:

Tablet glass bottle ISO 11418-4 – 60 – cl

4 Requirements

4.1 Material

The material shall be colourless (cl) or amber (br) borosilicate glass (see ISO 4802-1 or ISO 4802-2) or soda-lime-silica glass (see ISO 4802-1 or ISO 4802-2) of hydrolytic resistance grain class ISO 719 – HGB 3 or ISO 720 – HGA 2.

4.2 Performance

<https://standards.iteh.ai/catalog/standards/sist/cc8cc017-99aa-4b9c-a2e7-7658475954f8/iso-11418-4-2005>

4.2.1 Vertical load resistance

The resistance to vertical load shall be in accordance with ISO 8113.

4.2.2 Hydrolytic resistance

When tested in accordance with ISO 4802-1 or ISO 4802-2, the hydrolytic resistance of the internal surface of the tablet glass bottles shall comply with the requirements of the hydrolytic resistance container class ISO 4802 – HC 3.

4.2.3 Thermal shock resistance

Tablet glass bottles shall withstand the thermal shock of a temperature difference of 42 °C when tested in accordance with the thermal shock resistance test specified in ISO 7459.

5 Marking

The tablet glass bottle shall be marked with the information specified in Figure 1 (view Y).

Dimensions in millimetres

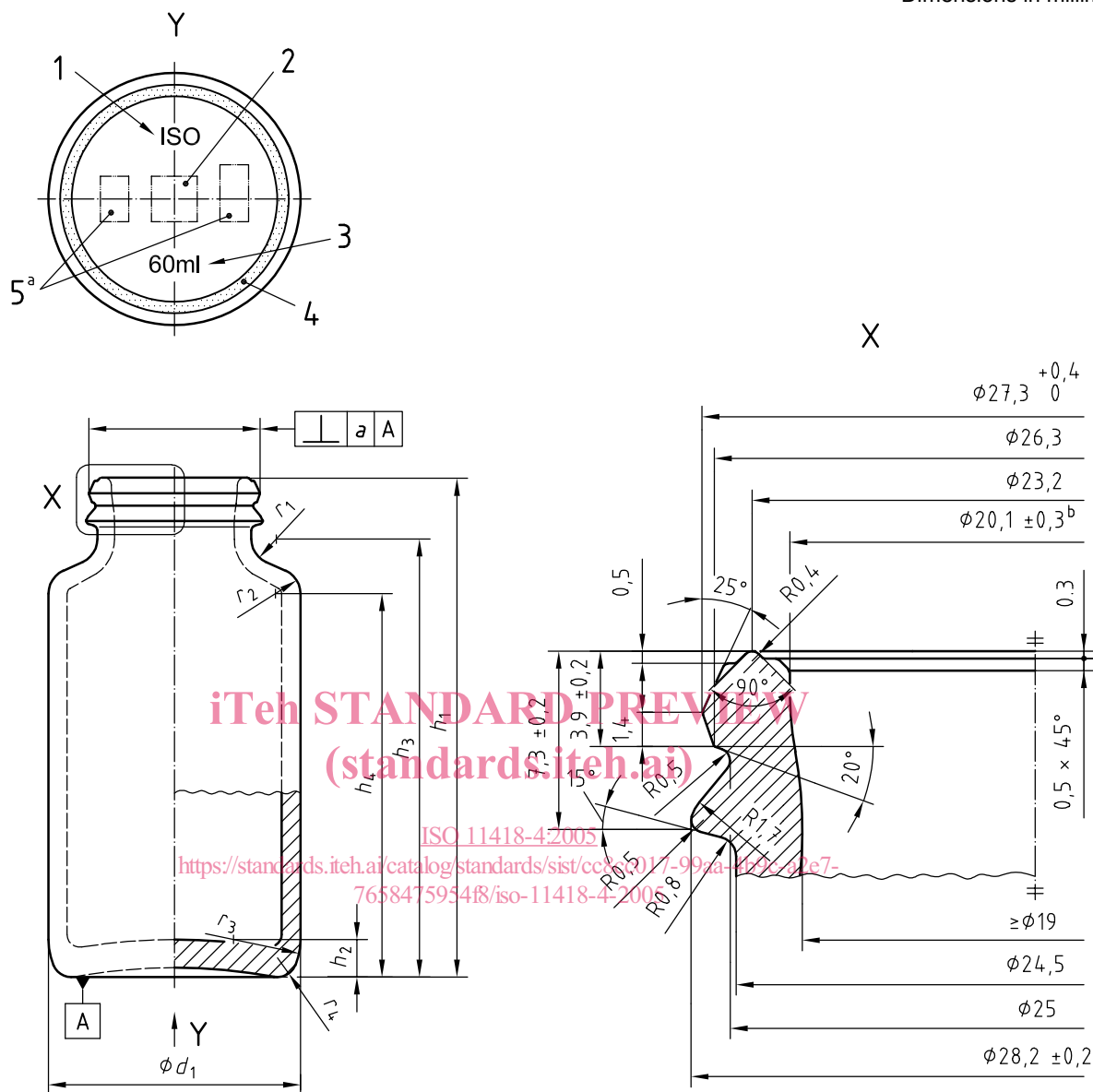

Key

- 1 ISO letters (optional)
- 2 manufacturer's trademark
- 3 nominal volume (optional)
- 4 bottom surface may be granular, flat or riffled
- 5 manufacturer's code/designation of the mould

^a The number of the mould may be placed on the curve r_3 , on the bottom or on the shoulder of the bottle.

^b On approximately 1 mm depth from the top of the neck; \varnothing 19,8 mm min. on approximately 3 mm depth.

Figure 1 — Typical tablet glass bottle, showing marking locations

Table 1 — Nominal volume, overflow capacity and dimensions of tablet glass bottles

Dimensions in millimetres

Nominal volume ml	Minimum overflow (brimful) capacity ml	a	d ₁		h ₁		h ₂	h ₃	h ₄	r ₁	r ₂	r ₃	r ₄	Mass g
			nom.	tol.	nom.	tol.								
10	12	0,65	31	± 0,7	33,7	± 0,5	1,5	24,4	18,6	4	3	—	1,5	20,5
20	24,5	0,85	31	± 0,7	54,9	± 0,6	2,5	45,6	39,8	4	3	—	2,5	30,5
40	44,5	1,0	40,2	± 0,8	60	± 0,6	6	49,9	41,2	4	4	10,7	3	43
60	65,5	1,1	40,2	± 0,8	79,6	± 0,7	6	70	61,2	4	4	10,7	3	48
80	85,5	1,2	47,5	± 0,8	81	± 0,7	9	71,2	60,2	4	5	25	3	80
100	105,6	1,2	47,5	± 0,8	97	± 0,8	10	87,2	76,2	4	5	25	3	95

Teh STANDARD PREVIEW
(standards.itech.ai)
ISO 11418-4:2005
http://standards.itech.ai/catalog/standards/ist/c88cc017-99aa-4b9c-a2e7-7658475954f8/iso-11418-4-2005

iTeh STANDARD PREVIEW
(standards.iteh.ai)

[ISO 11418-4:2005](#)

<https://standards.iteh.ai/catalog/standards/sist/cc8cc017-99aa-4b9c-a2e7-7658475954f8/iso-11418-4-2005>