

INTERNATIONAL
STANDARD

ISO
105-P02

Second edition
1993-10-01

Textiles — Tests for colour fastness —

Part P02:

Colour fastness to pleating: Steam pleating

iTeh STANDARD PREVIEW

(standards.iteh.ai)

Textiles — Essais de solidité des teintures —

Partie P02: Solidité des teintures au pliage: Plissage à la vapeur

<https://standards.iteh.ai/catalog/standards/sist/21c9de90-34b9-4348-9a96-7732e0549387/iso-105-p02-1993>

INTERNATIONAL

ISO



Reference number
ISO 105-P02:1993(E)

Foreword

ISO (the International Organization for Standardization) is a worldwide federation of national standards bodies (ISO member bodies). The work of preparing International Standards is normally carried out through ISO technical committees. Each member body interested in a subject for which a technical committee has been established has the right to be represented on that committee. International organizations, governmental and non-governmental, in liaison with ISO, also take part in the work. ISO collaborates closely with the International Electrotechnical Commission (IEC) on all matters of electrotechnical standardization.

Draft International Standards adopted by the technical committees are circulated to the member bodies for voting. Publication as an International Standard requires approval by at least 75 % of the member bodies casting a vote.

International Standard ISO 105-P02 was prepared by Technical Committee ISO/TC 38, *Textiles*, Sub-Committee SC 1, *Tests for coloured textiles and colorants*.

<https://standards.iteh.ai/catalog/standards/sist/21c9de90-34b9-4348-9a96-732094930720-iso-105-p02-1993>

This second edition cancels and replaces the first edition (included in ISO 105-P:1978), of which it constitutes a minor revision.

ISO 105 was previously published in thirteen "parts", each designated by a letter (e.g. "Part A"), with publication dates between 1978 and 1985. Each part contained a series of "sections", each designated by the respective part letter and by a two-digit serial number (e.g. "Section A01"). These sections are now being republished as separate documents, themselves designated "parts" but retaining their earlier alphanumeric designations. A complete list of these parts is given in ISO 105-A01.

© ISO 1993

All rights reserved. No part of this publication may be reproduced or utilized in any form or by any means, electronic or mechanical, including photocopying and microfilm, without permission in writing from the publisher.

International Organization for Standardization
Case Postale 56 • CH-1211 Genève 20 • Switzerland

Printed in Switzerland

Textiles — Tests for colour fastness —

Part P02:

Colour fastness to pleating: Steam pleating

1 Scope

1.1 This part of ISO 105 specifies a method for determining the resistance of the colour of textiles of all kinds and in all forms to the action of steam-pleating processes. The materials are not pleated during the test, and it is emphasized that the test is not intended for assessing the quality of the pleating process.

1.2 Three tests differing in severity are provided; one or more of them may be used depending on the requirements.

2 Normative references

The following standards contain provisions which, through reference in this text, constitute provisions of this part of ISO 105. At the time of publication, the editions indicated were valid. All standards are subject to revision, and parties to agreements based on this part of ISO 105 are encouraged to investigate the possibility of applying the most recent editions of the standards indicated below. Members of IEC and ISO maintain registers of currently valid International Standards.

ISO 105-A01:1989, *Textiles — Tests for colour fastness — Part A01: General principles of testing.*

ISO 105-A02:1993, *Textiles — Tests for colour fastness — Part A02: Grey scale for assessing change in colour.*

ISO 105-A03:1993, *Textiles — Tests for colour fastness — Part A03: Grey scale for assessing staining.*

ISO 105-F:1985, *Textiles — Tests for colour fastness — Part F: Standard adjacent fabrics.*

ISO 105-F10:1989, *Textiles — Tests for colour fastness — Part F10: Specification for adjacent fabric: Multifibre.*

ISO 139:1973, *Textiles — Standard atmospheres for conditioning and testing.*

3 Principle

A specimen of the textile in contact with either one or two specified adjacent fabrics is steamed under pressure and dried. The change in colour of the specimen, and the staining of the adjacent fabric(s), are assessed with the grey scales.

4 Apparatus and materials

4.1 Specimen holder (see figure 1), consisting of a copper tube 80 mm in external diameter. The thickness of the copper is 1,5 mm. The copper tube is wrapped with six layers of bleached cotton fabric of mass per unit area approximately 125 g/m², on which the test specimen is wrapped. Wrapped round the test specimen is an outer cover made from bleached cotton fabric of mass per unit area approximately 185 g/m². The outer cover is held in place by rods made from 6-mm-diameter mild steel, spring-fitted to the tube.

The strength of the springs is not critical, but it shall be sufficient to hold the cover tightly against the tube. The springs are conveniently fastened to one of the rods and should hook easily on to the other.

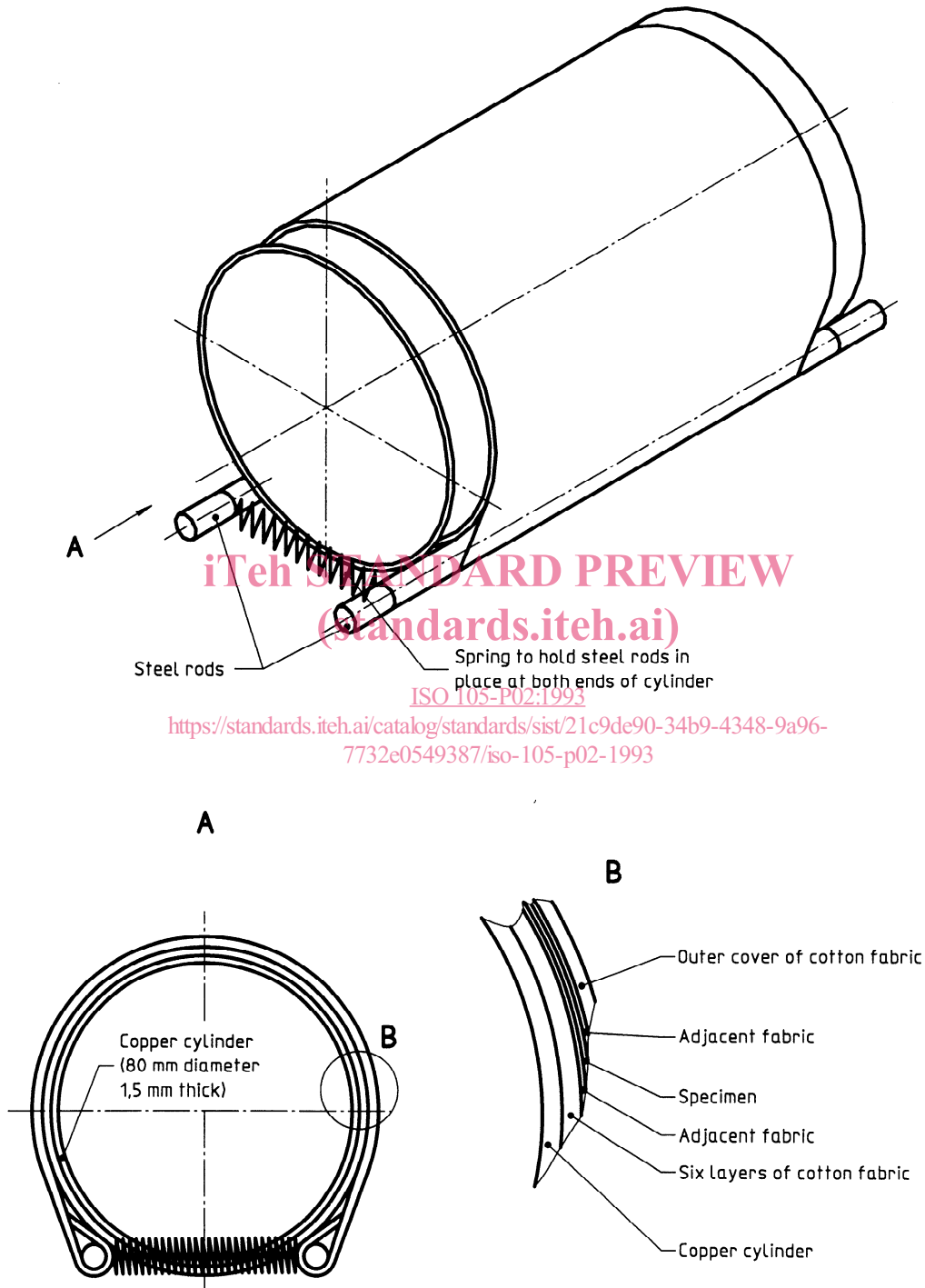

Figure 1 — Specimen holder

4.2 Jacketed steamer or pressure cooker.

Use

- a) a jacketed steamer designed so that the pressure can be accurately determined and that no water splashes on to the specimen during the test;

or

- b) a domestic pressure cooker sufficiently large to avoid water splashing on to the specimen during the test; the minimum size shall be 230 mm in diameter and 260 mm high, and it shall be fitted with an accurate pressure gauge.

The specimen holder (4.1) shall be loosely wrapped in one layer of polyester film which projects 10 mm over each end of the tube and is not closed at the ends.

The specimen holder shall be placed in a rectangular metal container containing ten 1 mm holes equally spaced along the centre of the bottom. The container shall be sufficiently deep to reach to 10 mm from the top of the specimen holder (see figure 2). The bottom of the container shall be slightly concave to ensure that condensed water drains away rapidly. The container shall be placed on a stand which holds it 50 mm above the surface of the water.

NOTE 1 The quantity of water in the cooker is not critical, but water to a depth of 30 mm is suggested.

Expel air from the pressure cooker for 2 min before raising the pressure.

Dimensions in millimetres

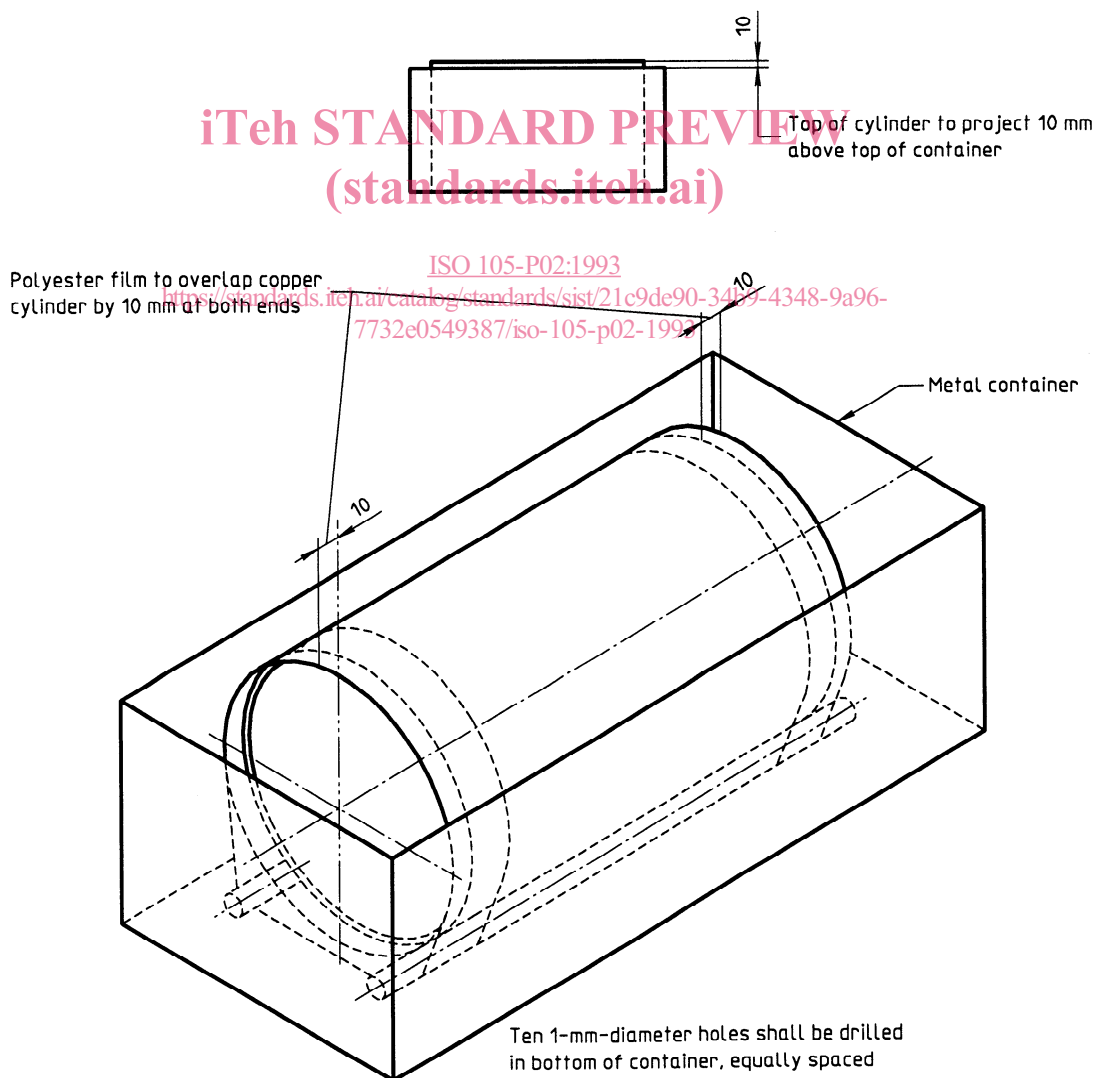

Figure 2 — Specimen holder in container

4.3 Adjacent fabrics (see ISO 105-A01:1989, sub-clause 8.3).

NOTE 2 If wool is used as one of the adjacent fabrics, it may have an adverse effect on the dye in the specimen, particularly under alkaline conditions.

Either:

4.3.1 A multifibre adjacent fabric, complying with ISO 105-F10.

Or:

4.3.2 Two single-fibre adjacent fabrics, complying with the relevant sections of F01 to F08 of ISO 105-F:1985, each measuring 40 mm × 50 mm and made of the same kind of fibre as that of the textile to be tested, or as otherwise specified. In the case of blends, two different adjacent fabrics are required, corresponding to the two predominant fibres of the specimen.

4.4 If required, a **non-dyeable fabric** (for example, polypropylene).

4.5 Grey scale for assessing change in colour, complying with ISO 105-A02, and **grey scale for assessing staining**, complying with ISO 105-A03.

5 Test specimen

5.1 If the textile to be tested is fabric,

- a) attach a specimen measuring 40 mm × 50 mm to a piece of the multifibre adjacent fabric (4.3.1), also measuring 40 mm × 50 mm, by sewing along one of the shorter sides, with the multifibre fabric next to the face of the specimen;

or

- b) attach a specimen measuring 40 mm × 50 mm between the two single-fibre adjacent fabrics (4.3.2), also measuring 40 mm × 50 mm, by sewing along one of the shorter sides.

5.2 Where yarn or loose fibre is to be tested, take a mass of the yarn or loose fibre approximately equal to one-half of the combined mass of the adjacent fabrics and

- a) place it between a 40 mm × 50 mm piece of the multifibre adjacent fabric and a 40 mm × 50 mm piece of the non-dyeable fabric (4.4) and sew them along all four sides (see ISO 105-A01:1989, sub-clause 9.6);

or

- b) place it between a 40 mm × 50 mm piece of each of the two specified single-fibre fabrics and sew along all four sides.

6 Procedure

6.1 Mount the composite specimen in the holder (4.1) as shown in figure 1.

6.2 Place the holder containing the composite specimen in a jacketed steamer or pressure cooker (4.2).

6.3 Steam under one of the conditions given in table 1.

6.4 When steaming is complete, release the pressure over a period not exceeding 2 min.

6.5 Open out the composite specimen and dry it by hanging it in air at a temperature not exceeding 60 °C with the three parts in contact only at one line of stitching. Condition for 4 h in air in the standard temperate atmosphere for testing as defined in ISO 139, i.e. a temperature of 20 °C ± 2 °C and relative humidity of (65 ± 2) %. In tropical countries, the standard tropical atmosphere for testing as defined in ISO 139 may be used, i.e. a temperature of 27 °C ± 2 °C and relative humidity of (65 ± 2) %.

6.6 Assess the change in colour of the specimen and the staining of the adjacent fabric with the grey scales (4.5).

6.7 Specimens which liberate formaldehyde under steam-pleating conditions shall be tested separately.

NOTE 3 It should be noted that the papers used in commercial pleating occasionally contain reducing agents which, with certain types of colouring matter, can produce a much greater change in colour than occurs under the test conditions.

7 Test report

The test report shall include the following particulars:

- a) the number and date of publication of this part of ISO 105, i.e. ISO 105-P02:1993;
- b) all details necessary for the identification of the sample tested;
- c) the numerical ratings for change in colour of the specimen;

- d) if single-fibre adjacent fabrics were used, the numerical rating for the staining of each kind of adjacent fabric used (if the fabrics were identical and showed different amounts of staining, report only the heavier staining);
- e) if a multifibre adjacent fabric was used, the type of multifibre adjacent fabric and the staining of each type of fibre in the multifibre adjacent fabric;
- f) the type of test carried out, i.e. mild, intermediate or severe (see table 1).

Table 1 — Steaming conditions

Test	Maximum duration of heating-up period	Duration of time at specified temperature	Pressure	Temperature
	min	min		
Mild	5	5	135	108
Intermediate	8	10	170	115
Severe	15	20	270	130

NOTE — The severe test is intended primarily for wholly synthetic textiles such as those made from polyamide and polyester fibres; it shall not be used for textiles containing wool.

iTeh STANDARD PREVIEW
(standards.iteh.ai)

ISO 105-P02:1993

<https://standards.iteh.ai/catalog/standards/sist/21c9de90-34b9-4348-9a96-7732e0549387/iso-105-p02-1993>

iTeh STANDARD PREVIEW
(standards.iteh.ai)

ISO 105-P02:1993

<https://standards.iteh.ai/catalog/standards/sist/21c9de90-34b9-4348-9a96-7732e0549387/iso-105-p02-1993>

UDC 677.016.47:677.027.615.22

Descriptors: textiles, dyes, tests, damp heat tests, determination, colour fastness, pleating.

Price based on 5 pages
