



SLOVENSKI STANDARD
oSIST prEN ISO 17643:2013
01-december-2013

Neporušitveno preskušanje zvarnih spojev - Preskušanje zvarov z metodo vrtinčnih tokov z vektorsko analizo (ISO/DIS 17643:2013)

Non-destructive testing of welds - Eddy current testing of welds by complex-plane analysis (ISO/DIS 17643:2013)

Zerstörungsfreie Prüfung von Schweißverbindungen - Wirbelstromprüfung von Schweißverbindungen durch Vektorauswertung (ISO/DIS 17643:2013)

Contrôle non destructif des assemblages soudés - Contrôle par courants de Foucault des assemblages soudés avec analyse des signaux dans le plan complexe (ISO/DIS 17643:2013)

Ta slovenski standard je istoveten z: prEN ISO 17643

ICS:

25.160.40 Varjeni spoji in vari Welded joints

oSIST prEN ISO 17643:2013 **en,fr,de**



DRAFT INTERNATIONAL STANDARD ISO/DIS 17643

ISO/TC 44/SC 5

Secretariat: AFNOR

Voting begins on
2013-06-20Voting terminates on
2013-11-20

INTERNATIONAL ORGANIZATION FOR STANDARDIZATION • МЕЖДУНАРОДНАЯ ОРГАНИЗАЦИЯ ПО СТАНДАРТИЗАЦИИ • ORGANISATION INTERNATIONALE DE NORMALISATION

Non-destructive testing of welds — Eddy current testing of welds by complex-plane analysis

Contrôle non destructif des assemblages soudés — Contrôle par courants de Foucault des assemblages soudés avec analyse des signaux dans le plan complexe

[Revision of first edition (ISO 17643:2005)]

ICS 25.160.40

iTeh STANDARD PREVIEW
(standards.iteh.ai)

ISO/CEN PARALLEL PROCESSING

This draft has been developed within the International Organization for Standardization (ISO), and processed under the **ISO-lead** mode of collaboration as defined in the Vienna Agreement.

This draft is hereby submitted to the ISO member bodies and to the CEN member bodies for a parallel five-month enquiry.

Should this draft be accepted, a final draft, established on the basis of comments received, will be submitted to a parallel two-month approval vote in ISO and formal vote in CEN.

To expedite distribution, this document is circulated as received from the committee secretariat. ISO Central Secretariat work of editing and text composition will be undertaken at publication stage.

Pour accélérer la distribution, le présent document est distribué tel qu'il est parvenu du secrétariat du comité. Le travail de rédaction et de composition de texte sera effectué au Secrétariat central de l'ISO au stade de publication.

THIS DOCUMENT IS A DRAFT CIRCULATED FOR COMMENT AND APPROVAL. IT IS THEREFORE SUBJECT TO CHANGE AND MAY NOT BE REFERRED TO AS AN INTERNATIONAL STANDARD UNTIL PUBLISHED AS SUCH.

IN ADDITION TO THEIR EVALUATION AS BEING ACCEPTABLE FOR INDUSTRIAL, TECHNOLOGICAL, COMMERCIAL AND USER PURPOSES, DRAFT INTERNATIONAL STANDARDS MAY ON OCCASION HAVE TO BE CONSIDERED IN THE LIGHT OF THEIR POTENTIAL TO BECOME STANDARDS TO WHICH REFERENCE MAY BE MADE IN NATIONAL REGULATIONS.

RECIPIENTS OF THIS DRAFT ARE INVITED TO SUBMIT, WITH THEIR COMMENTS, NOTIFICATION OF ANY RELEVANT PATENT RIGHTS OF WHICH THEY ARE AWARE AND TO PROVIDE SUPPORTING DOCUMENTATION.

iTeh STANDARD PREVIEW (standards.iteh.ai)

SIST EN ISO 17643:2015

<https://standards.iteh.ai/catalog/standards/sist/6cd148b3-8700-414a-9da0-906641cac5cc/sist-en-iso-17643-2015>



COPYRIGHT PROTECTED DOCUMENT

© ISO 2013

All rights reserved. Unless otherwise specified, no part of this publication may be reproduced or utilized otherwise in any form or by any means, electronic or mechanical, including photocopying, or posting on the internet or an intranet, without prior written permission. Permission can be requested from either ISO at the address below or ISO's member body in the country of the requester.

ISO copyright office
Case postale 56 • CH-1211 Geneva 20
Tel. + 41 22 749 01 11
Fax + 41 22 749 09 47
E-mail copyright@iso.org
Web www.iso.org

Published in Switzerland

Contents

Page

Foreword	iv
1 Scope	1
2 Normative references	1
3 Terms and definitions	1
4 Personnel qualification	1
5 Written procedures	2
6 General applications	2
6.1 Essential variables	2
6.2 Additional information	2
6.3 Surface conditions	2
6.4 Equipment	3
6.4.1 Instrumentation (excluding probe)	3
6.4.2 Surface probes	3
6.4.3 Accessories	4
6.4.4 Systematic equipment maintenance	5
6.5 Test procedure	6
6.5.1 Procedure for measuring coating thickness and material comparison relative to calibration block	6
6.5.2 Procedure for testing welds in ferritic materials	6
6.6 Detectability of discontinuities	12
6.7 Procedure for testing welds in other materials	13
7 Test report	13
Annex A (informative) Recommended Eddy current method flow diagram	15
Bibliography	16

Foreword

ISO (the International Organization for Standardization) is a worldwide federation of national standards bodies (ISO member bodies). The work of preparing International Standards is normally carried out through ISO technical committees. Each member body interested in a subject for which a technical committee has been established has the right to be represented on that committee. International organizations, governmental and non-governmental, in liaison with ISO, also take part in the work. ISO collaborates closely with the International Electrotechnical Commission (IEC) on all matters of electrotechnical standardization.

International Standards are drafted in accordance with the rules given in the ISO/IEC Directives, Part 2.

The main task of technical committees is to prepare International Standards. Draft International Standards adopted by the technical committees are circulated to the member bodies for voting. Publication as an International Standard requires approval by at least 75 % of the member bodies casting a vote.

Attention is drawn to the possibility that some of the elements of this document may be the subject of patent rights. ISO shall not be held responsible for identifying any or all such patent rights.

ISO 17643 was prepared by Technical Committee ISO/TC 44, *Welding and allied processes*, Subcommittee SC 5, *Testing and inspection of welds*.

This second/third/... edition cancels and replaces the first/second/... edition (), [clause(s) / subclause(s) / table(s) / figure(s) / annex(es)] of which [has / have] been technically revised.

Changes from the first edition include an informative Annex on method diagram.

[SIST EN ISO 17643:2015](https://standards.iteh.ai/catalog/standards/sist/6cd148b3-8700-414a-9da0-906641cac5cc/sist-en-iso-17643-2015)

<https://standards.iteh.ai/catalog/standards/sist/6cd148b3-8700-414a-9da0-906641cac5cc/sist-en-iso-17643-2015>

Non-destructive testing of welds — Eddy current testing of welds by complex-plane analysis

1 Scope

This International Standard defines eddy current testing techniques for detection of surface breaking and near surface planar discontinuities, mainly in ferritic materials (weld material, heat-affected zones, parent materials).

Eddy current testing can also be specified for use with non-ferritic materials, for example in an application standard.

The techniques can be applied to coated and uncoated objects during fabrication and in service, both onshore and offshore.

Eddy current testing can be carried out on all accessible surfaces and on welds of almost any configuration.

Unless otherwise specified for specific points in this International Standard, the general principles of EN 12084 apply.

NOTE Eddy current testing is usually performed in the as-welded condition. However, the accuracy of the results can be affected by very rough surface finishes.

2 Normative references

The following referenced documents are indispensable for the application of this document. For dated references, only the edition cited applies. For undated references, the latest edition of the referenced document (including any amendments) applies.

EN 1330-5, *Non-destructive testing — Terminology — Part 5: Terms used in Eddy current testing*

ISO 15549, *Non-destructive testing — Eddy current testing — General principles*

3 Terms and definitions

For the purposes of this document, the terms and definitions given in EN 1330-5 apply.

4 Personnel qualification

Non-destructive testing shall be performed by qualified and capable personnel. It is recommended that personnel are qualified in accordance with ISO 9712 or an equivalent standard at an appropriate level in the relevant industry sector.

ISO/DIS 17643

5 Written procedures

If a written procedure is required, it should be prepared in accordance with ISO 15549. Otherwise, the procedures detailed in this International Standard shall be followed.

6 General applications

6.1 Essential variables

Prior to eddy current testing, the following essential items shall be specified in accordance with ISO 15549:

- certification of testing personnel;
- testing plan;
- testing equipment;
- calibration of the equipment;
- calibration blocks;
- acceptance criteria;
- recording of indications;
- reporting format;
- actions necessary for non-acceptable indications.

6.2 Additional information

Prior to eddy current testing, the following information should be specified. Further information may be necessary for determination of the nature of the discontinuities and the composition or grade of the parent material:

- type of filler metal;
- location and extent of welds to be tested;
- weld surface geometry;
- surface conditions;
- coating type and thickness.

6.3 Surface conditions

Eddy current testing can be used to detect surface cracks through non-metallic coatings up to 2 mm thick. For coating thicknesses greater than 2 mm, the sensitivity of the test method shall be demonstrated in advance before eddy current testing is used.

NOTE 1 Eddy current testing is dependent on close contact between the probe and the test surface. For effective eddy current testing of welds, it should be noted that local adverse weld form, excessive weld spatter, scale, rust and loose paint can influence sensitivity by separating the probe from the test object and by inducing noisy responses.

NOTE 2 It should be noted that some types of conductive coating, such as thermally sprayed aluminium and lead, can seriously influence the results as they can deposit electrically conductive metallic material in cracks open to the surface. Cracks covered with such a metallic deposit are not always indicated by this method.

6.4 Equipment

6.4.1 Instrumentation (excluding probe)

6.4.1.1 General

The instrumentation used for eddy current testing in accordance with this International Standard shall be capable of analysis and display in the complex plane of both phase and amplitude and have at least the following features:

6.4.1.2 Frequency

The eddy current instrumentation shall be able to operate at a selected frequency within the range 1 kHz to 1 MHz.

6.4.1.3 Calibration of sensitivity levels

After balance and lift-off compensation and a further adjustment of the gain and phase controls, a 1 mm deep artificial discontinuity in a calibration block (see 6.4.3.1) shall be indicated as a full screen deflection through a coating thickness corresponding to the maximum expected on the structure to be examined.

A 0,5 mm deep artificial discontinuity in the same calibration block shall be indicated as a minimum of 50 % of the signal obtained from the 1 mm deep artificial discontinuity indication through the same coating thickness.

Both requirements shall apply to the chosen probe and shall be verified on a relevant calibration block (in accordance with 6.4.3.1).

If these requirements cannot be met, eddy current testing is not possible.

6.4.1.4 Signal display

As a minimum, the signal display shall be a complex-plane display with the facility to freeze data on screen until reset by the operator. The trace shall be clearly visible under all lighting conditions expected during testing.

6.4.1.5 Phase control

The phase control shall be able to give complete rotation (360°) in steps of no more than 10° each.

6.4.1.6 Evaluation mode

The evaluation mode shall use both phase analysis and amplitude analysis of a vector traced to the complex-plane display. Evaluation may be by comparison of this display with the reference data previously stored.

6.4.2 Surface probes

6.4.2.1 Probes for measuring coating thickness and material evaluation relative to calibration block

To be acceptable for this purpose, the probe shall be capable of providing a full screen deflection lift-off signal on the instrumentation when moved from an uncoated spot on a calibration block to a spot covered with the maximum coating thickness expected on the structure to be tested. The probe shall operate in the absolute mode at a selected frequency in the range from 1 kHz to 1 MHz. All the probes shall be clearly marked with their operating frequency range. (See Figure 1.)

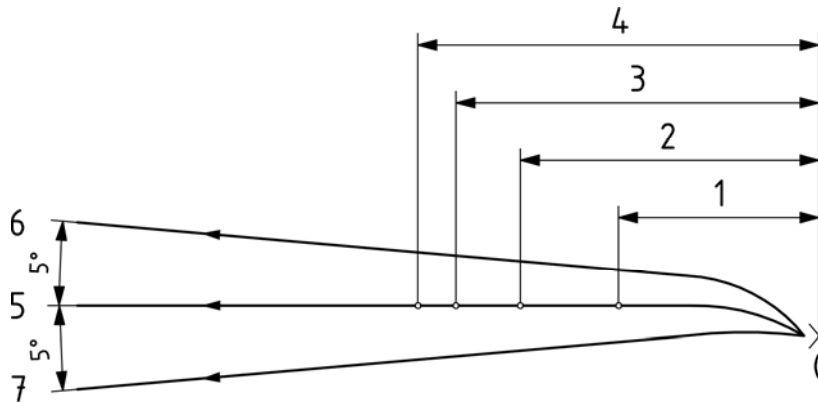
**Key**

- 0 balance point
- 1, 2, 3, 4 deflections representing variations in thickness of simulated coatings on calibration block
- 5 deflection representing material of calibration block
- 6, 7 deflection representing range of material to be examined using calibration block

Figure 1 — Coating thickness measurement and material sorting using absolute probe

6.4.2.2 Probes for testing of welds

For testing of ferritic welds, probes specially designed for this purpose shall be used. The probe assembly shall be differential, orthogonal, tangential or equivalent, which is characterized by having a minimal dependency on variations in conductivity, permeability and lift-off in the welded and heat-affected zones.

The diameter of the probe shall be selected relative to the geometry of the component under test. Such probes shall be able to operate when covered by a thin layer of non-metallic wear-resistant material over the active face. If the probe is used with a cover, then the cover shall always be in place during calibration. The probe shall operate at a selected frequency in the range from 100 kHz to 1 MHz.

6.4.3 Accessories

6.4.3.1 Calibration block

A calibration block, of the same type of material as the component to be examined, shall be used. It shall have EDM (electric discharge machined) notches of 0,5 mm, 1,0 mm and 2,0 mm depth, unless otherwise specified, for example in an application standard. The tolerance on the notch depth shall be $\pm 0,1$ mm. The recommended width of the notches is $\leq 0,2$ mm. An example of a calibration block is shown in Figure 2.

6.4.3.2 Non-conductive flexible strips

Non-conductive flexible strips of a known thickness to simulate the coating or actual coatings on the calibration block shall be used.

It is recommended that non-conductive flexible strips be multiples of 0,5 mm thickness.

6.4.3.3 Probe extension cables

Extension cables may only be used between the probe and the instrumentation if the function, sensitivity and the resolution of the whole system can be maintained.

6.4.3.4 Remote display and control

For operation with long extension cables, the equipment shall include a device for remote signal display at the operator's location.

Dimensions in millimetres

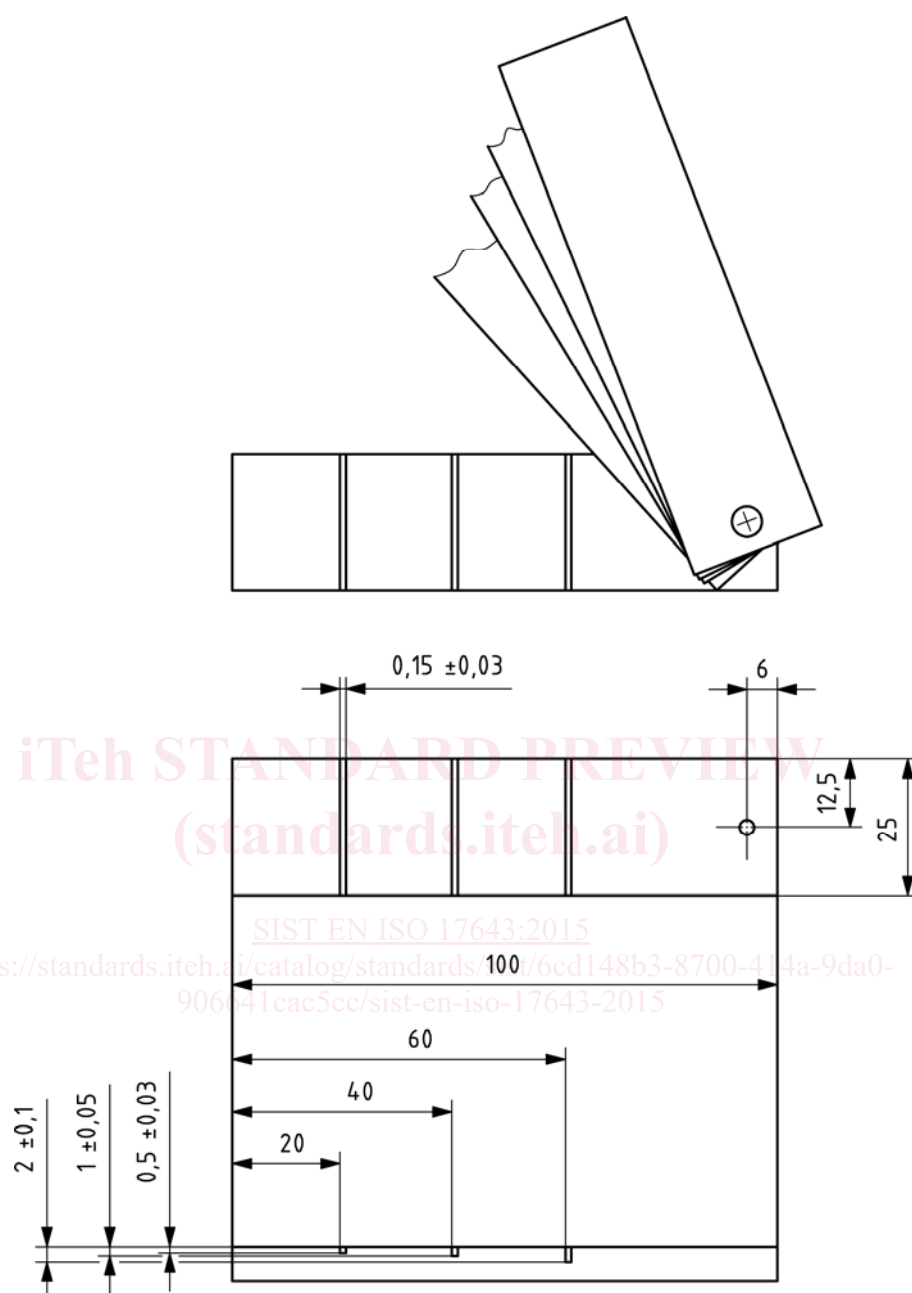

Figure 2 — Example of a calibration block

6.4.4 Systematic equipment maintenance

6.4.4.1 Calibration certificate

The equipment (instrumentation and probe) shall have a currently valid calibration certificate. This may be issued by the manufacturer, a recognized calibration laboratory or an authorized agency. The equipment shall be re-calibrated at least annually.