



Designation: F 1427 – 04^{ε1}

Standard Consumer Safety Specification for Bunk Beds¹

This standard is issued under the fixed designation F 1427; the number immediately following the designation indicates the year of original adoption or, in the case of revision, the year of last revision. A number in parentheses indicates the year of last reappraisal. A superscript epsilon (ϵ) indicates an editorial change since the last revision or reappraisal.

^{ε1} NOTE—Section 4.5.5 was editorially corrected in January 2005.

INTRODUCTION

This consumer safety specification addresses bunk bed accidents that were identified by the U.S. Consumer Product Safety Commission (CPSC).

The CPSC estimates that in 1989, about 34 000 bunk bed-related injuries were treated in U.S. hospital emergency rooms, and about three fourths of those injured were under the age of 15. Most of these injuries were minor and were associated with victims who fell from, bumped into, or jumped from bunk beds. However, there are other less-obvious potentially serious hazards associated with bunk beds. For example, from 1973 through November 1990, CPSC also received reports of 83 deaths of children less than 15 years of age involving bunk beds. Seventy-four incidents, including 17 deaths, involved children who reportedly became entrapped between the mattress and guardrail; 24 incidents, including five deaths, involved children who reportedly became entrapped either between the mattress and bed structure or in the bed end structure; and 18 incidents, including 16 deaths, involved young children who reportedly became entrapped between the bed and the wall. The CPSC also received reports of four deaths due to failure of the mattress support, 19 deaths due to falls from bunk beds, twelve deaths due to strangulation when a belt, rope, or clothing became caught on the bed structure, and ten deaths due to other or unknown causes.

1. Scope

1.1 This consumer safety specification establishes minimum requirements for the design and performance of bunk beds. It also contains requirements for labeling and instructional material.

1.2 This consumer safety specification is intended to minimize accidents to children resulting from normal use and reasonably foreseeable misuse or abuse of bunk beds. This consumer safety specification is written within the current state of the art of bunk bed technology and does not address bunk beds that are blatantly misused or are used in a careless manner

that disregards warning statements and safety instructions provided with each bunk bed.

1.3 For the purpose of this consumer safety specification, a bunk bed (hereinafter referred to as a bed) is defined as any bed in which the underside of the foundation is over 30 in. (762 mm) from the floor.

1.4 This consumer safety specification does not address bunk beds for institutional use (for example, in prisons, military facilities, dormitories, and so forth).

1.5 The values stated in inch-pound units are to be regarded as the standard. The values given in parentheses are for information only.

1.6 The following safety hazards caveat pertains only to the test methods portion, Section 5, of this specification: *This standard does not purport to address all of the safety concerns, if any, associated with its use. It is the responsibility of the user*

¹ This specification is under the jurisdiction of ASTM Committee F15 on Consumer Products and is the direct responsibility of Subcommittee F15.30 on Bunk Beds.

Current edition approved Oct. 1, 2004. Published October 2004. Originally approved in 1992. Last previous edition approved in 2001 as F 1427 – 01.

of this standard to establish appropriate safety and health practices and determine the applicability of regulatory limitations prior to use.

2. Referenced Documents

- 2.1 *ASTM Standards:*²
D 3359 Test Methods for Measuring Adhesion by Tape Test
- 2.2 *Federal Standards:*³
 16 CFR Part 1303 Ban of Lead-Containing Paint and Certain Consumer Products Bearing Lead-Containing Paint
 16 CFR Part 1500 Hazardous Substances Act Regulations, including sections:
 1500.48 Technical Requirements for Determining a Sharp Point in Toys and Other Articles Intended for Use by Children Under 8 Years of Age
 1500.49 Technical Requirements for Determining a Sharp Metal or Glass Edge in Toys and Other Articles Intended for Use by Children Under 8 Years of Age
 16 CFR Part 1501 Method for Identifying Toys and Other Articles Intended for Use by Children Under 3 Years of Age Which Present Choking, Aspiration or Ingestion Hazards Because of Small Parts
 16 CFR Part 1632 Standard for the Flammability of Mattresses and Mattress Pads⁴

3. Terminology

- 3.1 *Definitions of Terms Specific to This Standard:*
 - 3.1.1 *bed, n*—for the purpose of this specification, a bunk bed, as described in 3.1.5.
 - 3.1.2 *bed end structure, n*—upright unit at the head and foot of the bed, to which the side rails attach.
 - 3.1.3 *bed post, n*—upright post at each corner of the bed structure.
 - 3.1.4 *bed structure, n*—furniture parts assembled for the purpose of providing a sleeping environment.
 - 3.1.5 *bunk bed, n*—for the purpose of this specification, any bed in which the underside of the foundation is over 30 in. (762 mm) from the floor.
 - 3.1.6 *foundation, n*—of a bed, base or support for a mattress.
 - 3.1.6.1 *Discussion*—The foundation may be independent from or incorporated with the sleeping surface.
 - 3.1.7 *foundation support system, n*—of a bed, those components of the bed structure that support the foundation.
 - 3.1.8 *guardrail, n*—of a bed, rail attached to each long side of the bed to help prevent a sleeping occupant from rolling or sliding out of the bed.

- 3.1.9 *interior bed structure, n*—interior faces of the side rails and bed end structures.
- 3.1.10 *mattress, n*—manufactured product intended to be slept on, consisting of various resilient materials covered with an outer ticking.
- 3.1.11 *side rail, n*—of a bed structure, rail attached to the bed end structures to which the foundation support system is fastened.

4. Performance Requirements

- 4.1 *Fit of Top Bed to Bottom Bed*—The bed post shall be designed so that the minimum height of lift to allow horizontal disengagement of the top bed from the bottom bed shall be 1¼ in. (32 mm), or a fastening mechanism may be used that will prevent the disengagement of the top bed from the bottom bed.
- 4.2 *Mattress and Foundation Size and Fit*—There shall be no gaps between the interior bed structure and the edges of the mattress and foundation that will permit complete passage of the wedge block shown in Fig. 1 when tested in accordance with 5.2.
- 4.3 *Foundation Support System:*
 - 4.3.1 The foundation support system shall confine the horizontal position of the mattress and the foundation and shall prohibit the mattress and foundation from falling into the clearance over the lower bunk or to the floor when the mattress or foundation is manipulated.
 - 4.3.2 In the event cross-members are utilized, a minimum of two per bed are required. If more than two cross-members are utilized, they shall be spaced so that the distance between adjacent cross-members or between the cross-members and the bed end structures will not permit complete passage of the wedge block or will allow complete passage of both the wedge block and the 9 in. (230 mm) diameter rigid sphere when tested in accordance with 5.8.
 - 4.3.3 The foundation support system shall not be capable of being dislodged without the release of positive fastening devices or the use of hand tools.

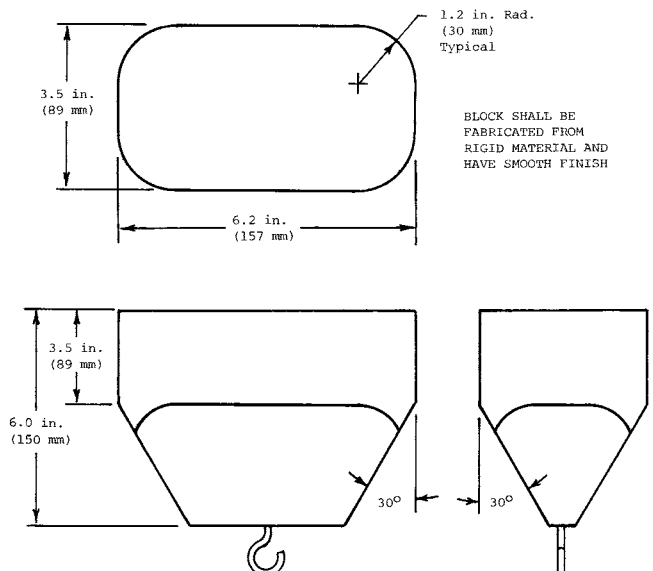

FIG. 1 Wedge Block for Tests in 5.2.3, 5.5.1, and 5.6.1

² For referenced ASTM standards, visit the ASTM website, www.astm.org, or contact ASTM Customer Service at service@astm.org. For *Annual Book of ASTM Standards* volume information, refer to the standard's Document Summary page on the ASTM website.

³ Federal regulations 16 CFR Part 1303, 16 CFR Section 1500.48, 16 CFR Section 1500.49, 16 CFR Part 1501, and 16 CFR Part 1632 are in effect and are administered by the CPSC. These federal regulations are not a part of this safety specification. This information is offered to all parties so that they know that these federal regulations must be adhered to outside the scope of this safety specification. Copies of the regulations may be obtained from The Office of the Secretary, U.S. Consumer Product Safety Commission, Washington, DC 20207.

⁴ If beds are accompanied by mattresses.

4.3.4 The foundation support system shall not fail when tested in accordance with 5.3.

4.4 Side Rails:

4.4.1 *Bolt-On Side Rails*, that attach at their ends or on their side to the bed post, shall be secured at each end by two bolts with a minimum size of ¼-in. (6-mm) diameter. For wood beds these bolts shall be spaced a minimum of 1½ in. (40 mm) apart on their centers. When the bolts are fully tightened in the assembled bed, no more than ¼ in. (6 mm) of thread shall be exposed.

4.4.2 *Hook-On Side Rails*, securely attached to the bed post. Hook-on attachments shall require an additional action other than an upwards force to disengage.

4.4.3 *Side Rail Attachments*—There shall be no structural failure of bed side rail fastening systems when tested in accordance with 5.4.

4.5 Guardrails:

4.5.1 Two guardrails shall accompany any bed in which the underside of the foundation is over 30 in. (762 mm) from the floor. Guardrails may be separate from or integral with the ladder.

4.5.2 Guardrails shall be attached in a manner that requires the intentional release of a fastening device or be so designed that they cannot be removed unless forces are applied sequentially in different directions.

4.5.3 The upper edge of the guardrails shall be at least 5 in. (130 mm) above the sleeping surface when a mattress of a thickness that is the maximum specified by the manufacturer's instructions is used on the bed.

4.5.4 With no mattress on the bed, there shall be no openings in the rigid bed structure below the lower edge of any opening of the guardrail that would permit complete passage of the wedge block shown in Fig. 1 when tested in accordance with 5.5.

4.5.5 A guardrail may terminate before reaching the bed end structure, providing there is no more than 15 in. (380 mm) between either end of the guardrail and the bed end structures in the same plane when measured at a point 5 in. (127 mm) above the sleeping surface as established by the maximum mattress thickness specified by the manufacturer. The second guardrail may terminate before reaching the bed end structure. If this guardrail terminates before reaching the bed end structure, there shall be no more than 0.22 in. (5.6 mm) between either end of the guardrail and the bed end structure when measured horizontally between the bed end structure and the nearest point on the guardrail.

4.6 Bed End Structure:

4.6.1 The upper edge of the upper bunk end structures for at least 50 % of the distance between the two posts at the head and foot of the upper bunk shall be at least 5 in. (130 mm) above the sleeping surface when a mattress and foundation of the maximum size and thickness specified by the manufacturer's instructional literature is used on the upper bunk.

4.6.2 There shall be no openings in the rigid end structures of the upper bunk that will permit the free passage of the wedge block shown in Fig. 1 when tested in accordance with 5.6.1.

This requirement shall apply only to that portion of the bed end structure that is above the foundation support system of the upper bunk.

4.6.3 When tested in accordance with 5.6.2, there shall be no openings in the end structures of the lower bunk that will permit free passage of the wedge block shown in Fig. 1, unless they are large enough to permit the free passage of a 9 in. (230 mm) diameter rigid sphere. This requirement does not apply to openings that are below the level of the lower bunk foundation support system. This requirement shall apply to that portion of the bed end structure that is between the level of the lower bunk foundation support system and the level of the upper bunk foundation support system.

4.6.4 When tested in accordance with 5.6.2.3 and 5.6.2.4, all portions of the boundary of any opening of the lower bunk end structure that permits free passage of a 9 in. (230 mm) diameter rigid sphere also must conform to the neck entrapment requirement.

4.7 Ladders:

4.7.1 A lean-on (slanted) or hang-on (vertical) ladder shall be supplied with each bunk bed set or the ladder may be incorporated as part of the bed structure. The ladder may be separate from or integral with the guardrail. The ladder shall be attached in a manner that prevents inadvertent disengagement, repositioning, or tilting while in use.

4.7.2 The width of the ladder shall be no less than 10 in. (250 mm) measured from the inside of the stiles. Vertical spacing of ladder steps shall be no greater than 12 in. (300 mm) when measured from the floor to the first step or between steps. When bed structures are used as ladders, vertical spacing may be up to 16 in. (400 mm).

4.8 *Metal Beds: Frame and Fastenings*—There shall be no separation of any of the attachments of the foundation support system to the end structures of the bed when tested in accordance with 5.7.1.1 and 5.7.2.

5. Test Methods

5.1 Assemble the bed in accordance with the provided instructions.

5.2 Mattress and Foundation Size and Fit (see 4.2):

5.2.1 Place the intended mattress and foundation, as specified by the instructions, on the bed.

5.2.2 Move the mattress and foundation horizontally to obtain the largest gap between the interior bed structure and the edge of the mattress and foundation.

5.2.3 Insert the wedge block shown in Fig. 1, tapered side downwards, and in the most adverse orientation, into any gap and gradually apply a 45-lbf (200-N) vertically downwards force. Sustain the force for a period of 1 min.

5.3 *Foundation Support System (see 4.3)*—Center a sheet of ¾-in. (19-mm) thick plywood with dimensions 19 in. (480 mm) by 37 in. (940 mm) on the manufacturer's intended foundation (37-in. dimension parallel to the long axis of the bed), and place weights with a total mass of 400 lb (181.4 kg) on the plywood sheet. The weights shall be applied gradually and shall remain in place for a minimum of 5 min.

5.4 *Side Rails (see 4.4)*—Apply a downward vertical force of 225 lbf (1000 N) gradually, 10 in. from the bed end