



Designation: F 1852 – 05

Standard Specification for “Twist Off” Type Tension Control Structural Bolt/Nut/Washer Assemblies, Steel, Heat Treated, 120/105 ksi Minimum Tensile Strength¹

This standard is issued under the fixed designation F 1852; the number immediately following the designation indicates the year of original adoption or, in the case of revision, the year of last revision. A number in parentheses indicates the year of last reapproval. A superscript epsilon (ε) indicates an editorial change since the last revision or reapproval.

1. Scope*

1.1 This specification covers two types of heat treated, steel, tension control bolt-nut-washer assemblies, also referred to as “sets.” These assemblies are capable of developing a minimum predetermined tension when installed by applying torque to the nut, while at the same time applying a counter torque to separate the spline end from the body of the bolt using an appropriate spline drive installation tool.

1.2 An assembly consists of a tension control bolt with spline end (covered by this specification) and a suitable nut and washer covered by reference to applicable ASTM specifications.

1.3 The fastener assemblies are intended for use in structural connections. These connections, installation procedures, and the use of alternate design structural bolts are covered under the requirements of the “Specification for Structural Joints Using ASTM A 325 or A 490 Bolts,” approved by the Research Council on Structural Connection.

1.4 The assemblies are available with either round (button or dome) heads, heavy hex structural heads, or alternate design heads described in Section 10 and Fig. 1, in sizes ½ to 1 ⅞ in. inclusive, in two types specified in Section 4.

1.5 Terms used in this specification are defined in Terminology F 1789 unless otherwise defined herein.

1.6 The following precautionary statement pertains only to the test method portions, Sections 13 and 14, of this Specification: *This standard does not purport to address all of the safety concerns, if any, associated with its use. It is the responsibility of the user of this standard to establish appropriate safety and health practices and determine the applicability of regulatory limitations prior to use.*

2. Referenced Documents

2.1 ASTM Standards:²

A 194/A 194M Specification for Carbon and Alloy Steel Nuts for Bolts for High Pressure or High Temperature Service, or Both

A 242/A 242M Specification for High-Strength Low-Alloy Structural Steel

A 325 Specification for Structural Bolts, Steel, Heat Treated, 120/105 ksi Minimum Tensile Strength

A 563 Specification for Carbon and Alloy Steel Nuts

A 588/A 588M Specification for High-Strength Low-Alloy Structural Steel with 50 ksi [345 MPa] Minimum Yield Point to 4-in. [100-mm] Thick

A 709/A 709M Specification for Carbon and High-Strength Low-Alloy Structural Steel Shapes, Plates, and Bars and Quenched-and-Tempered Alloy Structural Steel Plates for Bridges

A 751 Test Methods, Practices, and Terminology for Chemical Analysis of Steel Products

A 871/A 871M Specification for High-Strength Low-Alloy Structural Steel Plate With Atmospheric Corrosion Resistance

B 695 Specification for Coatings of Zinc Mechanically Deposited on Iron and Steel

D 3951 Practice for Commercial Packaging

F 436 Specification for Hardened Steel Washers

F 606 Test Methods for Determining the Mechanical Properties of Externally and Internally Threaded Fasteners, Washers, and Rivets

F 788/F 788M Specification for Surface Discontinuities of Bolts, Screws, and Studs, Inch and Metric Series

F 1470 Guide for Fastener Sampling for Specified Mechanical Properties and Performance Inspection

F 1789 Terminology for F16 Mechanical Fasteners

G 101 Guide for Estimating the Atmospheric Corrosion

¹ This specification is under the jurisdiction of ASTM Committee F16 on Fasteners and is the direct responsibility of Subcommittee F16.02 on Steel Bolts, Nuts, Rivets and Washers.

Current edition approved Jan. 1, 2005. Published January 2005. Originally approved in 1998. Last previous approved in 2004 as F 1852-04a.

² For referenced ASTM standards, visit the ASTM website, www.astm.org, or contact ASTM Customer Service at service@astm.org. For *Annual Book of ASTM Standards* volume information, refer to the standard’s Document Summary page on the ASTM website.

*A Summary of Changes section appears at the end of this standard.

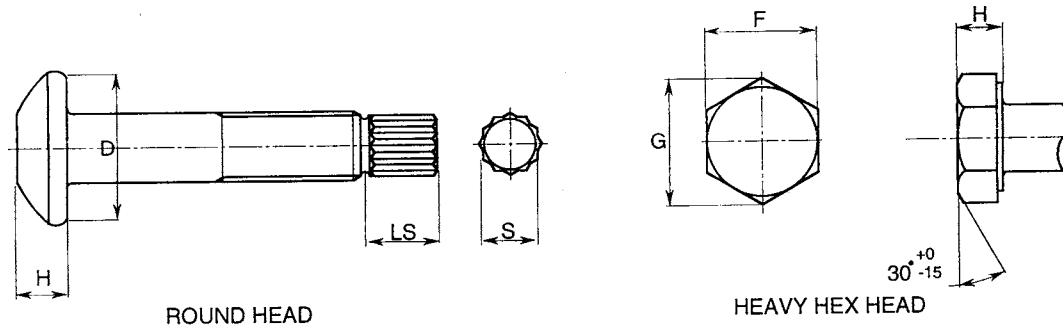

DIMENSIONS FOR TWIST OFF STRUCTURAL BOLT

NOMINAL SIZE OR BASIC PRODUCT DIAMETER	F		G		D	H		LS	S	
	WIDTH ACROSS FLAT		WIDTH ACROSS CORNERS		BEARING SURFACE DIAMETER	HEIGHT		LENGTH OF SPLINE	WIDTH ACROSS FLATS	
	MAX	MIN	MAX	MIN	MIN	MAX	MIN	REF.	REF.	
1/2"	0.500	0.875	0.850	1.010	0.969	0.890	0.323	0.302	0.50	0.32
5/8"	0.625	1.062	1.031	1.227	1.175	1.102	0.403	0.378	0.60	0.43
3/4"	0.750	1.250	1.212	1.443	1.383	1.338	0.483	0.455	0.65	0.53
7/8"	0.875	1.438	1.394	1.660	1.589	1.535	0.563	0.531	0.72	0.61
1"	1.000	1.625	1.575	1.876	1.796	1.771	0.627	0.591	0.80	0.70
1-1/8"	1.125	1.812	1.756	2.093	2.002	1.991	0.718	0.658	0.90	0.80
	A		A			A		B	B	

A These values are the same as the dimensions for Heavy Hex Structural Bolts specified in ANSI B18.2.1.

B The spline length (LS) and across the flat (S) dimensions are used for reference only. The grooved spline design may vary in size and shape.

NOTE 1—ANSI/ASME Subcommittee B 18.2.1 is currently preparing an American Standard to cover dimensional requirements for this product. Upon publication, these dimensions will be replaced with a reference to the American Standard for the dimensional requirements.

FIG. 1 Head and Spline Dimensions Inches

Resistance of Low-Alloy Steels

2.2 ANSI/ASME Standards:³

ASME B1.1 Unified Screw Threads

ANSI B18.2.1 Square and Hex Bolts and Screws

ANSI B18.18.3M Inspection and Quality Assurance for Special Purpose Fasteners

2.3 Research Council on Structural Connections

Specification for Structural Joints Using ASTM A 325 or A 490 Bolts⁴

3. Terminology

3.1 Definitions of Terms Specific to This Standard:

3.1.1 assembly lot—assembly lot for purposes of assigning identification numbers and from which test samples shall be

selected, shall consist of one combination of component lots. That is, one tension control bolt component lot, one nut component lot, and one washer component lot which are shipped as an assembly.

3.1.2 component lot—component lot, for the purpose of assigning an identification number and from which test samples shall be selected, shall consist of all tension control bolts, all nuts or all washers processed essentially together through all operations to the shipping container, of which each component has the following common characteristics: heat number (mill heat); ASTM designation and grade or type, as applicable; nominal dimensions (size) and head style; heat treatment lot; and coating lot, if applicable.

3.1.3 secondary processing—any processing performed by any entity on the assemblies or individual components after initial testing.

3.1.4 tension control bolt—bolt that includes an integral spline end which extends beyond the threaded portion of the bolt. The fastener is to be tightened using a special electric

³ Available from American National Standards Institute (ANSI), 25 W. 43rd St., 4th Floor, New York, NY 10036

⁴ Available from American Institute of Steel Construction (AISC), One E. Wacker Dr., Suite 3100, Chicago, IL 60601-2001.

wrench and socket system which has an inner socket that engages the spline end and with an outer socket that engages and turns the nut.

3.1.5 *tension control bolt assembly*—tension control bolt, nut and washer combination.

4. Classification

4.1 The tension control bolts are designed by type denoting chemical composition as follows:

- 4.1.1 *Type 1*—Plain carbon, carbon boron, or alloy steel.
- 4.1.2 *Type 3*—Weathering steel. Atmospheric corrosion resistance and weathering characteristics are comparable to that of steels in Specifications [A 242/A 242M](#), [A 588/A 588M](#), [A 709/A 709M](#), [A 871/A 871M](#), (see [7.1.2](#)).

5. Ordering Information

5.1 Orders for assemblies shall include the items of information below. Optional items not on the purchase order shall be considered as not being required, (see [Note 1](#)):

- 5.1.1 Quantity of assemblies
- 5.1.2 Size, include nominal tension control bolt diameter and length (without the spline end)
- 5.1.3 Name of product, that is, twist off type tension control bolt/nut/washer assemblies,
- 5.1.4 Head Style (see [10.1.1](#)),
- 5.1.5 Type of Assembly, that is; Type 1 or Type 3
- 5.1.6 ASTM designation and year of publication,
- 5.1.7 Mechanically zinc coated, if required, and
- 5.1.8 Special requirements, if required

NOTE 1—A typical order description follows: 2520 assemblies, 3/4 in. diameter by 2 in. long Tension Control Bolt/Nut/Washer Assemblies, Round Heads, Type 1 ASTM F 1852.

6. Materials and Manufacture

6.1 *Heat Treatment:*

6.1.1 Tension control bolts made from carbon or carbon boron steel shall be heat treated by quenching in a liquid medium from above the austenitizing temperature and then tempering by reheating to a temperature of at least 800°F (425°C).

6.1.2 Tension control bolts made from alloy steel shall be heat treated by quenching in oil from above the austenitizing temperature and then tempering by reheating to a temperature of at least 800°F (425°C).

6.2 *Thread*—The threads of tension control bolts shall be rolled.

6.3 *Mechanical Zinc Coating:*

6.3.1 When zinc coating is specified, each component of the assembly shall be mechanically zinc coated. The coating shall conform to Specification [B 695](#), Class 50 Type 1 as a minimum thickness.

6.3.2 Hot dip zinc coating shall not be permitted.

6.4 *Lubrication*— All nuts, plain and zinc coated, shall be lubricated. The lubricant shall be clean and dry to the touch.

NOTE 2—No further lubrication shall be permitted other than that applied by the manufacturer, as the type and amount of lubrication is critical to performance.

6.5 *Secondary Processing:*

6.5.1 If heat treatment, zinc coating, lubrication or other processing affecting properties are performed by any source on any unit of a component lot after the manufacturer’s test to qualify a lot has been performed, the component lot shall be treated as newly manufactured and shall be reinspected and retested in accordance with the requirements of its original manufacturing specification after such processing is completed. Retesting shall be the responsibility of the party supplying the component.

6.5.2 Secondary processing shall not be permitted to an assembly lot.

6.6 *Assembly:*

6.6.1 The assemblies shall be of the type specified by the purchaser.

6.6.2 The assemblies shall consist of one tension control bolt, with one lubricated nut and one or more washer(s).

6.6.3 Nuts and washers used on the assemblies shall conform to the requirements of the specifications below:

Assembly Type and Finish	Nut Specification, Class and Finish	Washer Specification, Type and Finish
Type 1 Plain ⁴	A 563 DH Plain A 563 C Plain	F 436 Type 1 Plain
Type 1 Mechanical Zinc Coated	A 563 DH Mechanical Zinc Coated	F 436 Type 1 Mechanical Zinc Coated
Type 3 Plain	A 563 DH3 Plain A 563 C3 Plain	F 436 Type 3 Plain

⁴ ASTM A 194-2H plain nuts are a suitable alternative for Type 1 plain nuts.

6.6.4 All nuts shall be Heavy Hex. All washers used in the assembly shall be circular and through hardened.

7. Chemical Composition

7.1 *Tension Control Bolts:*

7.1.1 Type 1 tension control bolts shall be plain carbon steel, carbon boron steel, or alloy steel, at the manufacturers option, and shall conform to one of the chemical compositions specified in [Table 1](#).

7.1.2 Type 3 tension control bolts shall be weathering steel and shall conform to one of the chemical compositions, specified in [Table 2](#). The selection of the chemical composition A, B, C, D, E, or F, shall be at the option of the manufacturer. See Guide [G 101](#) for method of estimating the atmospheric corrosion resistance of low alloy steels.

7.1.3 Product analysis, when performed, shall be made from finished material representing each lot. To meet the specification, the chemical composition thus determined shall conform to the requirements specified in [Table 1](#) or [Table 2](#) as applicable.

7.1.4 Heats of steel to which bismuth, selenium, tellurium, or lead has been intentionally added shall not be permitted.

7.1.5 For Type 1 bolts made from plain carbon steel or alloy steel, heats of steel which boron has been intentionally added shall not be permitted.

7.1.6 Compliance with [7.1.4](#) and [7.1.5](#) shall be based on certification that heats of steel having any of the listed elements intentionally added were not used to produce the bolts.

TABLE 1 Chemical Requirements for Type 1 Tension Control Bolts

Carbon Steel		
Element	Heat Analysis	Product Analysis
Carbon	0.30 to 0.52	0.28 to 0.55
Manganese, min	0.60	0.57
Phosphorus, max	0.040	0.048
Sulfur, max	0.050	0.058
Silicon	0.15 to 0.30	0.13 to 0.32
Boron	See 7.1.5 and 7.1.6	
Carbon Boron Steel		
Element	Heat Analysis	Product Analysis
Carbon	0.30 to 0.52	0.28 to 0.55
Manganese, min	0.60	0.57
Phosphorus, max	0.040	0.048
Sulfur, max	0.050	0.058
Silicon	0.10 to 0.30	0.08 to 0.32
Boron	0.0005 to 0.003	0.0005 to 0.003
Alloy Steel		
Element	Heat Analysis	Product Analysis
Carbon	0.30 to 0.52	0.28 to 0.55
Manganese	0.60	0.57
Phosphorus, max	0.035	0.040
Sulfur, max	0.040	0.045
Silicon	0.15 to 0.35	0.13 to 0.37
Boron	See 7.1.5 and 7.1.6	
Alloying Elements	A	A

^A Steel, as defined by the American Iron and Steel Institute, shall be considered to be alloy when the maximum of the range given for the content of alloying elements exceeds one or more of the following limits: manganese, 1.65 %, silicon, 0.60 %, copper, 0.60 %; or in which a definite range or a definite minimum quantity of any of the following elements is specified or required within the limits of the recognized field of constructional alloy steels: aluminum, chromium up to 3.99 %, cobalt, columbium, molybdenum, nickel, titanium, tungsten, vanadium, zirconium, or any other alloying elements added to obtain a desired alloying effect.

7.1.7 Chemical analysis shall be performed in accordance with Test Methods, Practices, and Terminology **A 751**.

7.2 *Nuts and Washers*— Chemical requirements for nuts and washers shall be in accordance with the applicable specification specified in **6.6.3**.

8. Mechanical Property Requirements for Tension Control Bolts

8.1 *Hardness*: The bolts shall conform to the hardness specified in **Table 3**.

8.2 *Tensile Properties*:

8.2.1 Bolts having a length of three times the diameter or longer (see **8.2.3**) shall be tested full size and shall conform to the tensile strength and proof load or alternative proof load specified in **Table 4**.

8.2.2 Bolts having a length less than three times the diameter are not subject to tensile tests, except as permitted in **8.2.3**.

8.2.3 Bolts having a length of two times the diameter or longer shall be permitted to be tested full size for tensile properties whenever suitable test equipment is available. In such cases reference to “three times the diameter” in **Table 3**, **8.2.1**, and **8.2.2** shall be considered to be “two times the diameter.”

8.2.4 For bolts on which hardness and tension tests are performed, acceptance based on tensile requirements shall take precedence in the event of controversy over low hardness tests.

8.3 *Nuts and Washers*— Mechanical properties for nuts and washers shall be in accordance with the applicable specification in **6.6.3**.

9. Assembly Lot Tension Test

9.1 *Purpose*—The assembly lot tension test shall be performed on fastener assemblies to determine the ability of the assembly to provide the required minimum tension.

9.2 *Requirement*— Full size completed assemblies tested in accordance with **14.4** shall develop a bolt tension when the spline end is separated from the bolt conforming to the requirements in **Table 5**, Column 1.

10. Dimensions

10.1 *Tension Control Bolts*:

10.1.1 Tension control bolts shall be furnished with either round (button or dome), heavy hex structural or alternate design heads; as specified by the purchaser.

10.1.2 The tension control bolts shall have a body conforming to the dimensions for heavy hex structural bolts specified in **ANSI B18.2.1** and a spline end conforming to the dimensions in **Fig. 1**.

10.1.3 Head designs as specified in **10.1.1** shall have a bearing surface area and head height equal to or larger than required for heavy hex structural bolts in **ANSI B18.2.1**.

10.1.4 Round heads shall conform to the dimensions in **Fig. 1**.

10.1.5 The thread length shall be as specified in **ANSI B18.2.1** for heavy hex structural bolts.

10.2 *Nuts and Washers*— The dimensions for nuts and washers shall be in accordance with the applicable specification specified in **6.6.3**.

10.3 *Threads*:

10.3.1 Threads on tension control bolts shall be the Unified Coarse Thread Series as specified in **ASME B1.1**, and shall have Class 2A tolerances.

10.3.2 Unless otherwise specified, zinc coated tension control bolts to be used with nuts which have been tapped oversize in accordance with Specification **A 563**, shall have Class 2A threads before mechanically deposited zinc coating.

10.3.3 The gaging limit for bolts shall be verified during manufacture. In case of purchaser/supplier controversy over thread compliance, System 21 of **ANSI B18.18.3M** shall be used for referee purposes.

11. Workmanship, Finish, and Appearance

11.1 Surface discontinuity limits for tension control bolts, inspection, and evaluation of the surface discontinuities, quench cracks, forging cracks, head bursts, shear bursts, seams, folds, thread laps, voids, tool marks, nicks, and gouges shall be in accordance with Specification **F 788/F 788M** (see **Note 3**).

NOTE 3—Specification **F 788/F 788M** and Guide **F 1470** do not guarantee 100 % freedom from head bursts. Sampling is designed to provide a 95 % confidence level of freedom from head bursts in any test lot. Head bursts, within the limits in Specification **F 788/F 788M**, are unsightly but do not affect mechanical properties or functional requirements of the bolt.

11.2 Surface discontinuity limits for the nut component shall be in accordance with the applicable specification specified in **6.6.3**.