**Elevating work platforms —
Mast-climbing work platforms**

Plates-formes élévatrices de personnel — Plate-formes se déplaçant le long de mât(s)

iTeh STANDARD PREVIEW
(standards.iteh.ai)

ISO 16369:2007

<https://standards.iteh.ai/catalog/standards/sist/1ba445e4-786c-4f54-a4a1-f8c0e7d68b59/iso-16369-2007>



PDF disclaimer

This PDF file may contain embedded typefaces. In accordance with Adobe's licensing policy, this file may be printed or viewed but shall not be edited unless the typefaces which are embedded are licensed to and installed on the computer performing the editing. In downloading this file, parties accept therein the responsibility of not infringing Adobe's licensing policy. The ISO Central Secretariat accepts no liability in this area.

Adobe is a trademark of Adobe Systems Incorporated.

Details of the software products used to create this PDF file can be found in the General Info relative to the file; the PDF-creation parameters were optimized for printing. Every care has been taken to ensure that the file is suitable for use by ISO member bodies. In the unlikely event that a problem relating to it is found, please inform the Central Secretariat at the address given below.

iTeh STANDARD PREVIEW
(standards.iteh.ai)

[ISO 16369:2007](https://standards.iteh.ai/catalog/standards/sist/1ba445e4-786c-4f54-a4a1-f8c0e7d68b59/iso-16369-2007)

<https://standards.iteh.ai/catalog/standards/sist/1ba445e4-786c-4f54-a4a1-f8c0e7d68b59/iso-16369-2007>



COPYRIGHT PROTECTED DOCUMENT

© ISO 2007

All rights reserved. Unless otherwise specified, no part of this publication may be reproduced or utilized in any form or by any means, electronic or mechanical, including photocopying and microfilm, without permission in writing from either ISO at the address below or ISO's member body in the country of the requester.

ISO copyright office
Case postale 56 • CH-1211 Geneva 20
Tel. + 41 22 749 01 11
Fax + 41 22 749 09 47
E-mail copyright@iso.org
Web www.iso.org

Published in Switzerland

Contents

Page

Foreword.....	iv
Introduction	v
1 Scope	1
2 Normative references	2
3 Terms and definitions.....	3
4 List of hazards.....	7
5 Safety requirements and/or measures	10
5.1 Structural and stability calculations	10
5.2 General requirements for machine, base frame, chassis and mast.....	18
5.3 Work platform.....	22
5.4 Drive systems for elevation	24
5.5 Means to prevent the work platform from falling with overspeed.....	29
5.6 Means for emergency lowering and raising the work platform	31
5.7 Overload/moment device	32
5.8 Electrical systems.....	33
5.9 Drive systems powered by internal combustion engine	34
5.10 Hydraulic system	35
5.11 Special requirements for safety devices depending on auxiliary circuits, and for overload/moment detection devices.....	36
5.12 Travel limit switches.....	36
5.13 Controls	36
6 Verification of safety requirements and/or measures for each new model of MCWP	37
6.1 Design check.....	37
6.2 Practical tests.....	37
7 Information to be provided	39
7.1 Instruction handbook	39
7.2 Marking	46
Annex A (informative) Structural calculations	47
Annex B (normative) Special requirements for multilevel work platforms	63
Annex C (normative) Requirements for electrical and electronic aspects for overload-detection devices	65
Bibliography	68

Foreword

ISO (the International Organization for Standardization) is a worldwide federation of national standards bodies (ISO member bodies). The work of preparing International Standards is normally carried out through ISO technical committees. Each member body interested in a subject for which a technical committee has been established has the right to be represented on that committee. International organizations, governmental and non-governmental, in liaison with ISO, also take part in the work. ISO collaborates closely with the International Electrotechnical Commission (IEC) on all matters of electrotechnical standardization.

International Standards are drafted in accordance with the rules given in the ISO/IEC Directives, Part 2.

The main task of technical committees is to prepare International Standards. Draft International Standards adopted by the technical committees are circulated to the member bodies for voting. Publication as an International Standard requires approval by at least 75 % of the member bodies casting a vote.

Attention is drawn to the possibility that some of the elements of this document may be the subject of patent rights. ISO shall not be held responsible for identifying any or all such patent rights.

ISO 16369 was prepared by Technical Committee ISO/TC 214, *Elevating work platforms*.

This second edition cancels and replaces the first edition (ISO 16369:2000), which has been technically revised.

ITIH STANDARD PREVIEW
(standards.iteh.ai)

ISO 16369:2007

<https://standards.iteh.ai/catalog/standards/sist/1ba445e4-786c-4f54-a4a1-f8c0e7d68b59/iso-16369-2007>

Introduction

This International Standard is one of a series of standards produced by ISO/TC 214 as part of its programme of work regarding standardization of terminology, ratings, general principles (technical performance requirements and risk assessment), safety requirements, test methods, maintenance and operation for elevating work platforms used to raise (elevate) and position personnel (and related work tools and materials) to a work position where a task is to be performed.

The extent to which hazards are covered is indicated in the scope of this International Standard. In addition, ISO 12100-1 and ISO 12100-2 address lifting equipment hazards which are not covered by this International Standard.

iTeh STANDARD PREVIEW (standards.iteh.ai)

[ISO 16369:2007](https://standards.iteh.ai/catalog/standards/sist/1ba445e4-786c-4f54-a4a1-f8c0e7d68b59/iso-16369-2007)

<https://standards.iteh.ai/catalog/standards/sist/1ba445e4-786c-4f54-a4a1-f8c0e7d68b59/iso-16369-2007>

iTeh STANDARD PREVIEW
(standards.iteh.ai)

ISO 16369:2007

<https://standards.iteh.ai/catalog/standards/sist/1ba445e4-786c-4f54-a4a1-f8c0e7d68b59/iso-16369-2007>

Elevating work platforms — Mast-climbing work platforms

1 Scope

This International Standard specifies particular safety requirements for mast-climbing work platforms (MCWP) which are temporarily installed and are manually or power-operated, and which are designed to be used by one or more persons from which to carry out work.

NOTE The vertical-moving components (work platforms) are also used to move those same persons and their equipment and materials to and from a single boarding point. These restrictions differentiate MCWP from builder's hoists.

This International Standard is also applicable to permanently installed MCWP.

This International Standard is applicable to work platforms which are elevated by a drive system and guided by and moved along their supporting masts, where the masts may or may not require lateral restraint from separate supporting structures.

This International Standard is applicable to any combination of the following alternatives:

- one or more masts;
- mast tied or untied;
- mast of fixed or variable length;
- masts vertical or inclined between 0° and 30° to the vertical;
- masts which are standing or hanging;
- movable or static base (chassis or base frame);
- manual or power-operated elevation;
- towed or self-powered ground travel on site, excluding road traffic regulation requirements;
- driven using electric, pneumatic, hydraulic motors or internal combustion engines.

This International Standard identifies the hazards arising during the various phases in the life of such equipment and describes methods for the elimination or reduction of these hazards and for the use of safe working practices.

This International Standard does not specify the requirements for dealing with the hazards involved in the manoeuvring, erection or dismantling, fixing or removing of any materials or equipment which are not part of the MCWP, nor does it deal with the handling of specific hazardous materials.

This International Standard does not specify the requirements for delivering persons and materials to fixed landing levels. Such equipment is referred to as lifts or hoists and is dealt with by other International Standards.

This International Standard does not apply to mobile elevating work platforms (MEWPs) in accordance with ISO 16368, suspended access equipment in accordance with EN 1808 or lifting tables in accordance with EN 1570.

2 Normative references

The following referenced documents are indispensable for the application of this document. For dated references, only the edition cited applies. For undated references, the latest edition of the referenced document (including any amendments) applies.

ISO 4301-1, *Cranes and lifting appliances — Classification — Part 1: General*

ISO 4302, *Cranes — Wind load assessment*

ISO 6336-1, *Calculation of load capacity of spur and helical gears — Part 1: Basic principles, introduction and general influence factors*

ISO 6336-2, *Calculation of load capacity of spur and helical gears — Part 2: Calculation of surface durability (pitting)*

ISO 6336-3, *Calculation of load capacity of spur and helical gears — Part 3: Calculation of tooth bending strength*

ISO 6336-5, *Calculation of load capacity of spur and helical gears — Part 5: Strength and quality of materials*

ISO 8686-1, *Cranes — Design principles for loads and load combinations — Part 1: General*

ISO 12100-2:2003, *Safety of machinery — Basic concepts, general principles for design — Part 2: Technical principles*

<https://standards.iteh.ai/catalog/standards/sist/1ba445e4-786c-4f54-a4a1-888888888888/iso-16369-2007>

ISO 13849-1:2006, *Safety of machinery — Safety-related parts of control systems — Part 1: General principles for design*

ISO 13852, *Safety of machinery — Safety distances to prevent danger zones being reached by the upper limbs*

ISO 13854, *Safety of machinery — Minimum gaps to avoid crushing of parts of the human body*

IEC 60065, *Audio, video and similar electronic apparatus — Safety requirements*

IEC 60204-1:2005, *Safety of machinery — Electrical equipment of machines — Part 1: General requirements*

IEC 60529, *Degrees of protection provided by enclosures (IP Code)*

IEC 60947-5-1:2003, *Low-voltage switchgear and controlgear — Part 5-1: Control circuit devices and switching elements — Electromechanical control circuit devices*

EN 614-1, *Safety of machinery — Ergonomic design principles — Part 1: Terminology and general principles*

EN 953, *Safety of machinery — Guards — General requirements for the design and construction of fixed and movable guards*

EN 982, *Safety of machinery — Safety requirements for fluid power systems and their components — Hydraulics*

3 Terms and definitions

For the purposes of this document, the following terms and definitions apply.

NOTE Elements of MCWP defined below are illustrated in Figures 1 and 2.

3.1

rated load

load for which the MCWP has been designed for normal operation, as stated in the load diagram

3.2

load diagram

notice displayed on the work platform showing the permitted number of persons and the mass and distribution of materials for the particular configuration

3.3

rated speed

vertical or horizontal speed for which the MCWP has been designed

3.4

transfer

any horizontal movement of the MCWP from one position to another on the same working site

3.5

transfer condition

configuration of the MCWP in which it is moved from one position to another on the same working site, including any limitation on the weather and the load or persons on the MCWP

3.6

transport

any movement of the MCWP outside the boundaries of the working site

3.7

transport condition

configuration of the MCWP in which it is moved outside the boundaries of the working site

EXAMPLE Road transport.

3.8

transfer [transport] interlocks

any design features on the MCWP which prevent unsafe transfer [transport]

3.9

base frame

part of the MCWP which provides support for the mast and elevating assembly

3.10

chassis

part of the MCWP which provides mobility and support for the mast and elevating assembly

3.11

rail-mounted chassis

chassis designed to transmit horizontal as well as vertical force to the ground via rails

3.12

outrigger

support at the base-frame level used to maintain or increase the stability of the MCWP within specified conditions

NOTE Outriggers can also be used for levelling.

3.13

outrigger beam

part of an outrigger assembly which moves in an essentially horizontal plane and may be powered or operated manually

3.14

mast

structure that supports and guides the platform

3.15

fixed-length mast

mast whose length cannot be varied, even by the attachment of further mast sections

3.16

variable-length mast

mast whose length can be varied by the attachment of successive lengths of prepared sections

3.17

guide

part of the mast which provides guiding for the work platform

3.18

mast tie

anchorage system used to provide lateral restraint to the mast from a building or other structure

3.19

work platform

vertical travelling part of the installation upon which the persons, equipment and materials are carried and from which work is carried out

iTeh STANDARD PREVIEW
(standards.iteh.ai)

NOTE The work platform includes the main platform and any platform extension, in contrast to the MCWP, which refers to the whole of the installation, including work platform, mast, mast ties, base and chassis.

ISO 16369:2007
<https://standards.iteh.ai/catalog/standards/sist/1ba445cd/86c4f54-ada1-f8c0e7d68b59/iso-16369-2007>

3.20

available platform area

area of the work platform, measured at the work platform floor level

3.21

main platform

part of the work platform built up using primary structural elements

3.22

platform extension

additional part of the work platform, built up using secondary structural elements, whose support and location is dependent upon the main platform

NOTE Platform extensions are used to extend the main work platform, usually along its longitudinal working edge. They can form irregular shapes which conform with the work site. They can also extend at a level just above or below the main platform level.

3.23

multilevel work platform

two or more work platforms travelling on the same mast or an additional working level attached to and totally supported by a work platform

NOTE For illustration, see Annex B.

3.24

counter-roller

roller used to counteract the gear-meshing separation forces between a rack and pinion

3.25**automatic brake**

device to decelerate and stop moving parts in case of interruption of the power supply

3.26**buffer**

stop at the end of travel, comprising a resilient means of arrest using fluids, springs or similar means

3.27**overspeed**

any speed above rated speed

3.28**overspeed detector**

device which, when the work platform attains a predetermined speed above rated speed, causes the overspeed safety device to be applied

3.29**overspeed safety device**

mechanical device for stopping and maintaining the work platform stationary on the mast in the event of overspeed

3.30**competent person**

person having the practical and theoretical knowledge and the experience of a particular MCWP needed to carry out a function satisfactorily

3.31**user****user organization**

person or organization having direct control over use of the MCWP

3.32**rack and pinion drive system**

drive system using a gearing arrangement consisting of a cylindrical gear (pinion) which engages a linear gear (rack) attached to the mast

3.33**ratchet drive system**

drive system that operates by attaching a ratcheting device to the rungs or other element of the mast in an alternating manner and elevates or lowers the platform a predefined distance

NOTE The platform can be supported by a pawl or similar device when the drive mechanism is not engaged.

3.34**screw drive system**

drive system consisting of a mast-mounted rack which meshes with a powered drive screw attached to the platform

NOTE Rotation of the powered drive screw elevates or lowers the platform.

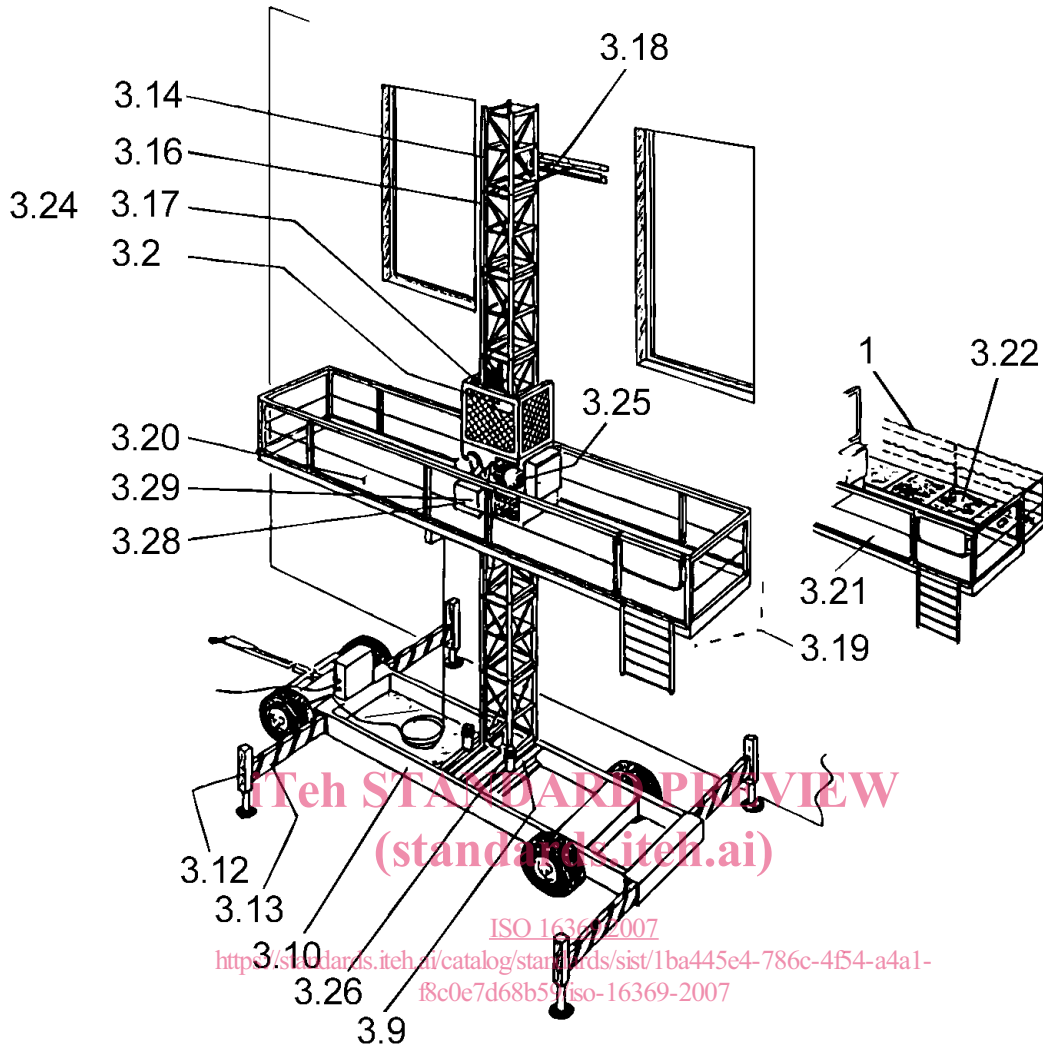

Key

1 removable handrails

NOTE Numbers correspond to terms and definitions given in Clause 3.

Figure 1 — Typical single-mast MCWP

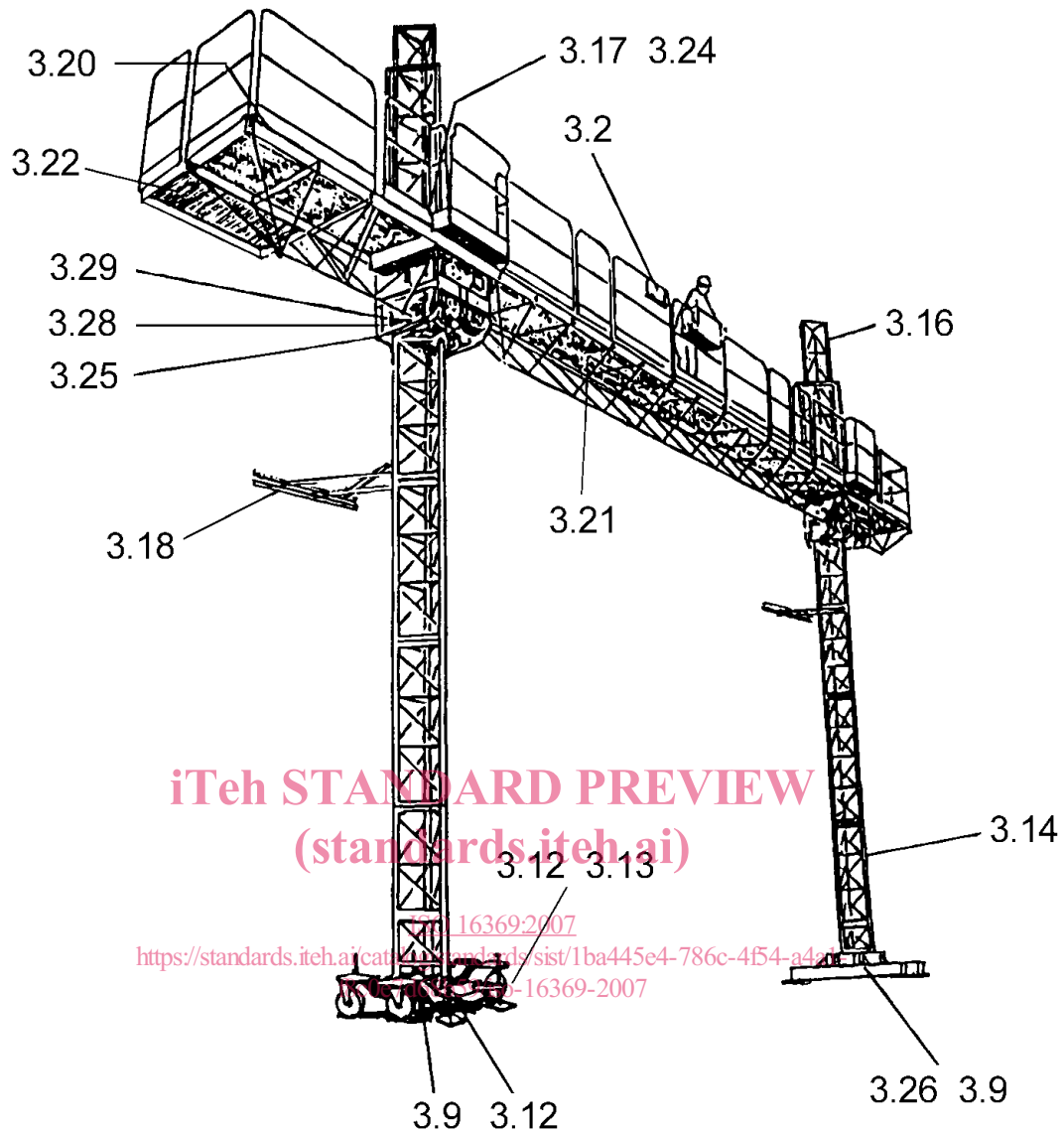

NOTE Numbers correspond to terms and definitions given in Clause 3.

Figure 2 — Typical twin-mast MCWP

4 List of hazards

The list of hazards according to Table 1 is based on ISO 12100-1 and ISO 12100-2.

Table 1 lists the hazards which have been identified and where corresponding requirements have been formulated in this International Standard in order to limit the risk or reduce these hazards in each situation.

A hazard which is not applicable or is not significant and for which, therefore, no requirements are formulated in this International Standard, is shown in the relevant clauses column as NA (not applicable).

Table 1 — List of hazards

Hazard	Relevant clauses in this International Standard
1 Mechanical hazards	
1.1 Crushing	5.2.1.3; 5.3.2; 5.4.1
1.2 Shearing	5.2.1.3; 5.3.2; 5.4.1
1.3 Cutting or severing	5.3.2; 5.4.1
1.4 Entanglement	5.4.1
1.5 Drawing-in or trapping	5.2.1.3; 5.3.2; 5.4.1
1.6 Impact	5.4.6
1.7 Stabbing or puncture	NA
1.8 Friction or abrasion	NA
1.9 High-pressure fluid ejection	5.10.1.7; 5.10.1.8; 5.10.1.9; 5.10.1.10
1.10 Ejection of parts	5.2.1.4; 5.2.1.5
1.11 Loss of stability	5.1.5; 5.2.2.4; 5.2.2.5; 5.2.5
1.12 Slip, trip and fall	5.2.2.1; 5.3.1
2 Electrical hazards	
2.1 Electrical contact	5.8
2.2 Electrostatic phenomena	NA
2.3 Thermal radiation	NA
2.4 External influences	5.7.15, Annex B
3 Thermal hazards	
3.1 Burns and scalds from possible exposure of persons to flames or explosions and also to radiation from heat sources	5.9.1; 5.9.2; 5.9.3
3.2 Health-damaging effects of hot or cold work environment	5.9.2
4 Hazards generated by noise	
Relevant but not dealt with	
5 Hazards generated by vibration	
5.1.2.3.2	
6 Hazards generated by radiation	
NA	
7 Hazards generated by materials and substances processed, used or emitted by machinery	
7.1 Contact with or inhalation of harmful fluids, gases, mists, fumes and dusts	5.9.2; 5.10
7.2 Fire or explosion	5.9.3; 5.9.4
7.3 Biological and microbiological hazards	NA
8 Hazards generated by neglecting ergonomic principles in machine design	
8.1 Unhealthy postures or excessive effort	5.2.1.6; 5.2.5.2; 5.6.2; 5.13; 5.13.8
8.2 Inadequate consideration of human hand/arm or foot/leg anatomy	NA
8.3 Neglected use of personal protection equipment	5.13.8
8.4 Inadequate area lighting	7.1.2 f)
8.5 Mental overload or underload, stress	NA
8.6 Human error	5.2.2.1; 5.13

Table 1 (continued)

Hazard	Relevant clauses in this International Standard
9 Hazard combinations	5.1.1.1; 5.1.1.2; 5.1.3
10 Hazards caused by failure of energy supply, breakdown of machinery parts and other functional disorders	5.1
10.1 Failure of energy supply	5.2.2.1; 5.6; 5.8.1.2; 5.12.7
10.2 Unexpected ejection of machine parts or fluids	5.10.1.7; 5.10.1.8; 5.10.1.9; 5.10.1.10
10.3 Failure or malfunction of control system	5.2.1.5
10.4 Errors of fitting	5.1.5.1.5
10.5 Overturn, unexpected loss of machine stability	5.1.1.2; 5.1.5; 5.7
11 Hazards caused by missing and/or incorrectly positioned safety-related measures/means	
11.1 Guards	5.2.1.3; 5.3.2; 5.4.1; 5.9.1; 7.1.2 f); 7.1.2 i); 7.1.2 l); 7.2.2;
11.2 Safety-related (protection) devices	5.7
11.3 Starting and stopping devices	5.1.1; 5.12
11.4 Safety signs and signals	5.2.2.7; 7.2
11.5 Information or warning devices	7.2
11.6 Energy-supply disconnecting devices	5.2.1.2; 5.8.2.1
11.7 Emergency devices	5.5; 5.6
11.8 Means of feeding/removal of work pieces	NA
11.9 Essential equipment and accessories for safe adjustment and/or maintenance	5.2.3.1; 5.4.2.9; 5.4.3.1.2; 5.4.4.3.5
11.10 Equipment for evacuating gases	5.9.1; 5.9.2; 5.9.3
HAZARDS INVOLVING THE MOBILITY AND LOAD-LIFTING ABILITY OF MCWP	
12 Inadequate lighting of moving/working area	7.1.2 f)
13 Hazards due to sudden movement, instability, etc. during handling	5.1.5; 5.2.2.1; 5.2.2.3; 5.2.2.4; 5.4.5
14 Inadequate/non-ergonomic design of operating position	
14.1 Hazards due to dangerous environments (contact with moving parts, exhaust gases, etc.)	5.2.2; 5.9.1; 5.9.2
14.2 Inadequate visibility from operator's position	5.13.2; 5.13.5
14.3 Inadequate seat/seating	NA
14.4 Inadequate/non-ergonomic design/positioning of controls	5.13
14.5 Starting/moving of self-propelled machinery	5.13
14.6 Road traffic of self-propelled machinery	7.1.2 f)
14.7 Movement of pedestrian-controlled machinery	7.1.2 f)
15 Mechanical hazards	
15.1 Hazards to persons exposed to uncontrolled movement	5.2.2.1; 5.2.4; 5.3.1.5; 5.4.1; 7.1.2 f)
15.2 Hazards due to break-up and/or ejection of parts	5.2.1.4; 5.2.1.5; 5.2.2.3
15.3 Hazards due to rolling over (ROPS)	5.1.5
15.4 Hazards due to falling objects (FOPS)	7.1.2 f)