



SLOVENSKI STANDARD
oSIST prEN 16565:2013
01-maj-2013

Embalaža - Prožne tube - Preskusna metoda za ugotavljanje orientacije zaskočnega pokrova

Packaging - Flexible tubes - Test method to determine the orientation of the flip-top cap

Verpackung - Tuben - Prüfmethode zur Bestimmung der Ausrichtung des Klappdeckelverschlusses

Emballage - Tubes souples - Méthodes d'essai pour déterminer l'orientation de l'obturateur à charnière

<https://standards.iteh.ai/catalog/standards/sist/8aaf2096-8011-4e8d-b57f-b400e8197051/sist-en-16565-2014>

Ta slovenski standard je istoveten z: prEN 16565

ICS:

55.120

Pločevinke. Tube

Cans. Tins. Tubes

oSIST prEN 16565:2013

en,fr,de

EUROPEAN STANDARD
NORME EUROPÉENNE
EUROPÄISCHE NORM

DRAFT
prEN 16565

February 2013

ICS 55.120

English Version

Packaging - Flexible tubes - Test method to determine the orientation of the flip-top cap

Emballage - Tubes souples - Méthode d'essai pour la détermination de l'orientation de l'obturateur à charnière

Verpackung - Tuben - Prüfmethode zur Bestimmung der Ausrichtung des Klappdeckelverschlusses

This draft European Standard is submitted to CEN members for enquiry. It has been drawn up by the Technical Committee CEN/TC 261.

If this draft becomes a European Standard, CEN members are bound to comply with the CEN/CENELEC Internal Regulations which stipulate the conditions for giving this European Standard the status of a national standard without any alteration.

This draft European Standard was established by CEN in three official versions (English, French, German). A version in any other language made by translation under the responsibility of a CEN member into its own language and notified to the CEN-CENELEC Management Centre has the same status as the official versions.

CEN members are the national standards bodies of Austria, Belgium, Bulgaria, Croatia, Cyprus, Czech Republic, Denmark, Estonia, Finland, Former Yugoslav Republic of Macedonia, France, Germany, Greece, Hungary, Iceland, Ireland, Italy, Latvia, Lithuania, Luxembourg, Malta, Netherlands, Norway, Poland, Portugal, Romania, Slovakia, Slovenia, Spain, Sweden, Switzerland, Turkey and United Kingdom.

Recipients of this draft are invited to submit, with their comments, notification of any relevant patent rights of which they are aware and to provide supporting documentation.

Warning : This document is not a European Standard. It is distributed for review and comments. It is subject to change without notice and shall not be referred to as a European Standard.



EUROPEAN COMMITTEE FOR STANDARDIZATION
COMITÉ EUROPÉEN DE NORMALISATION
EUROPÄISCHES KOMITEE FÜR NORMUNG

Management Centre: Avenue Marnix 17, B-1000 Brussels

Contents

Page

Foreword.....	3
1 Scope.....	4
2 Normative references.....	4
3 Test principle and testing equipment.....	4
4 Execution.....	5
5 Test report.....	6

iTeh STANDARD PREVIEW
(standards.iteh.ai)

SIST EN 16565:2014

<https://standards.iteh.ai/catalog/standards/sist/8aaf2096-8011-4e8d-b57f-b400e8197051/sist-en-16565-2014>

Foreword

This document (prEN 16565:2013) has been prepared by Technical Committee CEN/TC 261 “Packaging”, the secretariat of which is held by AFNOR.

This document is currently submitted to the CEN Enquiry.

iTeh STANDARD PREVIEW (standards.iteh.ai)

SIST EN 16565:2014

<https://standards.iteh.ai/catalog/standards/sist/8aaf2096-8011-4e8d-b57f-b400e8197051/sist-en-16565-2014>

1 Scope

This European Standard specifies a method to test the orientation of the flip-top cap on flexible tubes.

It is applicable to aluminium, plastic and laminated tubes used for packing pharmaceutical, cosmetic, hygiene, food and other domestic and industrial products.

2 Normative references

The following documents, in whole or in part, are normatively referenced in this document and are indispensable for its application. For dated references, only the edition cited applies. For undated references, the latest edition of the referenced document (including any amendments) applies.

EN 12374, *Packaging — Flexible tubes — Terminology*

3 Test principle and testing equipment

The test principle is described in Figure 1.

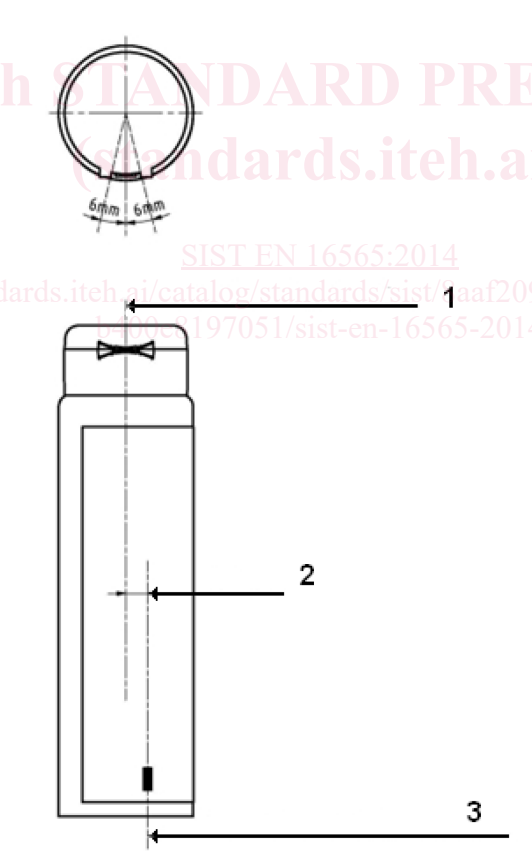

- 1 Axis of symmetry of cap hinge
- 2 Deviation
- 3 Axis of symmetry of back printed face

Figure 1 — Test principle

Any test equipment which is able to accurately measure the correct orientation of the flip-top cap can be used. An example for a suitable test device is given in Figure 2.

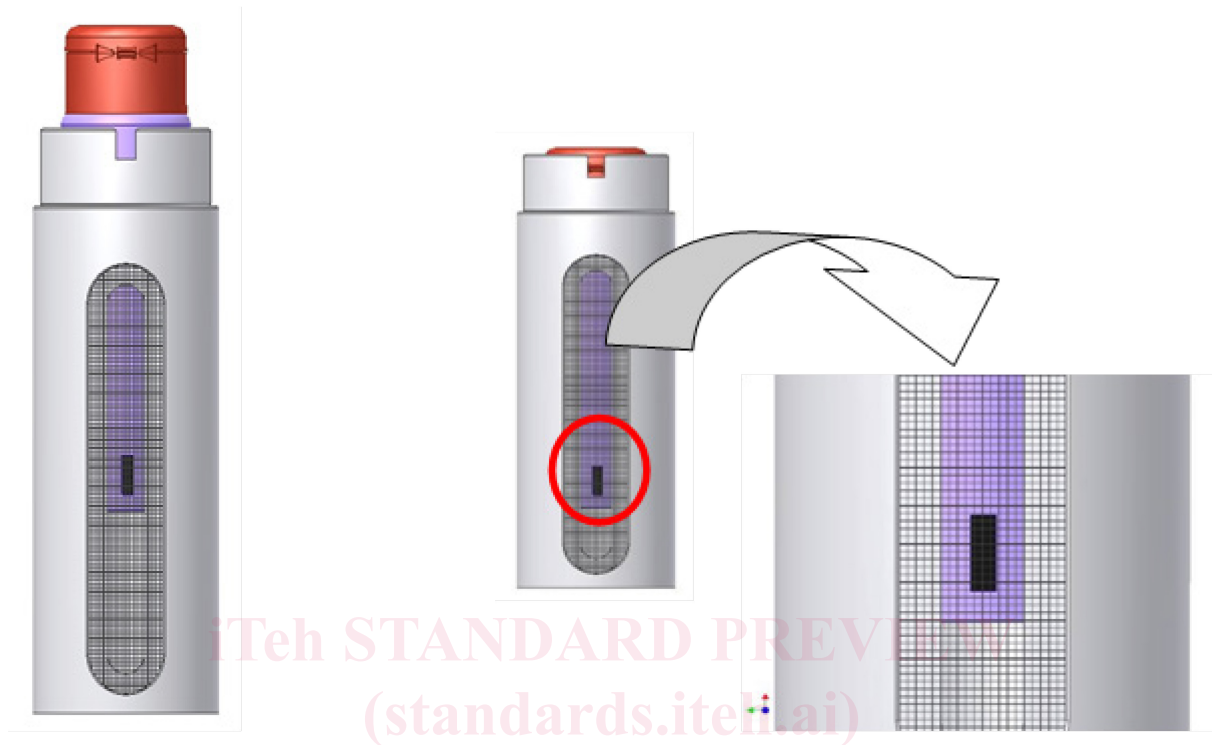

Figure 2 — Example for test device and measurement

<https://standards.iteh.ai/catalog/standards/sist/8aaf2096-8011-4e8d-b57f-b400e8197051/sist-en-16565-2014>

4 Execution

Take samples of the finished product (empty tube including flip-top cap).

Measure the deviation with the test device.

Read the deviation.

The maximum deviation shall stay within the limits given in Table 1.