



Designation: F1915 – 05

## Standard Test Methods for Glazing for Detention Facilities<sup>1</sup>

This standard is issued under the fixed designation F1915; the number immediately following the designation indicates the year of original adoption or, in the case of revision, the year of last revision. A number in parentheses indicates the year of last reapproval. A superscript epsilon ( $\epsilon$ ) indicates an editorial change since the last revision or reapproval.

### 1. Scope

1.1 These test methods, including a fire test response method, cover the apparatus, procedures, and acceptance conditions for evaluating the normal operational performance and the performance characteristics under assault conditions of detention glazing used in window and door assemblies in detention and correctional facilities; thus, these test methods only give an indication of the performance characteristics of detention glazing in actual service. Such variables as installation and maintenance conditions are not considered except as otherwise included in this test method.

1.2 It is the intent of these test methods to help ensure that detention glazing performs at or above minimum acceptable levels to restrict inmate passage to unauthorized areas, to confine inmates, to delay and frustrate escape attempts and to resist vandalism.

1.3 Tools defined in these test methods are representative of similar tools or materials, which may become available to inmates within the secure perimeter of detention and correctional facilities, and which could be used to inflict similar product damage.

1.4 These test methods should not be used to establish or confirm the absolute prevention of forced entries or exits. These test methods define five factors (tool, temperature, techniques, time, and number of impacts) used to determine resistance to defined attacks.

1.5 The values stated in inch-pound units are to be regarded as the standard. The SI values in stated parentheses are for information only.

1.6 In these test methods, the specimens are subjected to one or more specific sets of laboratory test conditions. If different test conditions are substituted or the end-use conditions are changed, it is not always possible by or from these test methods to predict changes in the physical attack, or fire-test-response characteristics measured, or both; therefore, the results are valid only for the physical attack, or fire-test-exposure conditions, or both, described in these test methods.

1.7 This standard does not purport to address all of the safety concerns, if any, associated with its use. It is the responsibility of the user of this standard to establish appropriate safety and health practices and determine the applicability of regulatory limitations prior to use.

### 2. Referenced Documents

#### 2.1 ASTM Standards:<sup>2</sup>

F1233 Test Method for Security Glazing Materials And Systems

F1450 Test Methods for Hollow Metal Swinging Door Assemblies for Detention and Correctional Facilities

F1577 Test Methods for Detention Locks for Swinging Doors

F1592 Test Methods for Detention Hollow Metal Vision Systems

F1643 Test Methods for Detention Sliding Door Locking Device Assembly

F1758 Test Methods for Detention Hinges Used on Detention-Grade Swinging Doors

#### 2.2 UL Standard:<sup>3</sup>

UL 752 Bullet Resisting Equipment

#### 2.3 NIJ Standard:<sup>4</sup>

NIJ 0108.1 Ballistic Resistant Protective Materials

### 3. Terminology

#### 3.1 Definitions of Terms Specific to This Standard:

3.1.1 *benchmark*, *n*—endpoint or intermediate point in the test sequence as determined by the certification agency.

3.1.2 *detention security*, *n*—assurance of the restriction of mobility of inmates to designated areas within a correctional or detention facility.

3.1.3 *forcible egress*, *n*—ability to pass a 5 by 8 by 8-in. (127 by 203.2 by 203.2-mm) rigid box through an opening in the test sample created by destructive testing procedures with no more than 10 lb (44.48 N) of force.

<sup>2</sup> For referenced ASTM standards, visit the ASTM website, [www.astm.org](http://www.astm.org), or contact ASTM Customer Service at [service@astm.org](mailto:service@astm.org). For *Annual Book of ASTM Standards* volume information, refer to the standard's Document Summary page on the ASTM website.

<sup>3</sup> Available from Underwriters Laboratories (UL), Corporate Progress, 333 Pfingsten Rd., Northbrook, IL 60062.

<sup>4</sup> Available from National Institute of Justice (NIJ), 810 7th St., NW, Washington, DC 20531.

<sup>1</sup> These test methods are under the jurisdiction of ASTM Committee F33 on Detention and Correctional Facilities and are the direct responsibility of Subcommittee F33.02 on Physical Barriers.

Current edition approved Feb. 1, 2005. Published February 2005. Originally approved in 1998. Last previous edition approved in 2003 as F1915 – 03. DOI: 10.1520/F1915-05.

3.1.4 *frame, n*—assembly of members surrounding and supporting a window or windows.

3.1.5 *glazing, n*—any infill material, usually transparent or translucent glass, polycarbonate, or combination thereof, used in a security detention frame.

3.1.6 *glazing stop, n*—formed metal section used to secure glazing or panel in a frame.

3.1.7 *head or header, n*—horizontal member that forms the top of a frame.

3.1.8 *hollow metal, n*—term used in reference to such items as doors, frames, partitions, enclosures, and other items that are fabricated from metal sheet, usually carbon steel.

3.1.9 *jamb, n*—vertical member forming the side of a frame.

3.1.10 *manufacturer, n*—party responsible for the fabrication of the test samples.

3.1.11 *performance characteristic, n*—response of the glazing sample in any one of the tests described herein.

3.1.12 *tamper-resistant security screw, n*—screw that is designed to be removed only by special tools kept by facility maintenance personnel.

3.1.13 *test completion, n*—conduct of one test sequence for each of the glazing samples resulting in either successful completion of the test sequence or the attainment of forcible egress.

3.1.14 *testing laboratory, n*—independent materials testing laboratory not associated with any manufacturer.

3.1.15 *vision system frame, n*—an assembly of members surrounding and supporting glazing panels, steel panels, or combinations thereof, that are located in an interior partition or exterior wall.

## 4. Significance and Use

4.1 The predictable and reliable performance of detention glazing used in detention and correctional facilities is a major concern. These test methods aid in assigning a level of physical security to glazing used in window and door assemblies based upon objective tests which can be consistently duplicated.

4.2 These test methods identify four security grades, corresponding to the four security grades established in Test Methods F1450. The intent is to establish a comparable level of performance for opening assemblies which incorporate detention glazing in conjunction with window and door assemblies. Test methods for detention glazing differ in sequencing a variety of attack tools and temperatures.

4.3 These test methods evaluate the resistance of detention glazing to attacks using blunt and sharp impact devices and fire. These test methods evaluate the performance of glazing in hot and cold environments. These test methods do not provide a measure of the resistance or performance of glazing subjected to attack by ballistics, chemical agents, explosives or other extreme methods of attack. Where such elements are a factor, consult the manufacturer.

4.4 The primary purpose of these test methods is to approximate the levels of abuse and operating conditions to which detention glazing is subjected in detention and correctional institutions. The desired result of these test methods is to provide a measure of assurance of protection to the correctional personnel, public, and inmates.

4.5 Detention and correctional facility administrative staff are encouraged to provide adequate training, supervision, and preventative maintenance programs to enable detention glazing assemblies to function as intended.

## 5. Sample Selection, Size, and Specimen Preparation

5.1 Samples manufactured for testing purposes shall be representative of the types and styles intended for use in the application of these test methods. The manufacturer shall provide three test samples of each product, one for each test. The test size shall be a nominal 3 ft, 0 in. (914.4 mm) wide by 4 ft, 0 in. (1219.2 mm) high.

5.2 Test reports shall include complete details as identified in Section 8.

5.3 Fig. 1 shows an acceptable test fixture and the location of the strike points described in Tables 1 and 2.

5.4 *For Nonsymmetrical Materials*—The “threat side” of the product shall be identified by the manufacturer and attacked during the test procedure.

## 6. Test Methods

### 6.1 Cold Temperature Impact Test:

6.1.1 *Scope*—These test methods are designed to evaluate the capability of detention glazing to resist repeated impact forces from both a blunt and sharp impactor under cold temperature conditions.

6.1.2 *Significance and Use*—These test methods are intended to closely simulate a sustained battering ram style or pounding type attack and provide an evaluation of the capability of the glazing to prevent, delay, or frustrate escape or access to unauthorized areas under cold temperature conditions. These test results are intended to aid in assigning a level of physical security to various configurations of detention glazing. An impact test of this design performed on detention glazing evaluates the impact strength of the glazing and its components as well as the quality of fabrication techniques.

### 6.1.3 Apparatus:

6.1.3.1 *Large Blunt Impactor*—The blunt impactor shall consist of a hinged or pivoted system with a mass of 80 lbs (36.32 kg) capable of delivering impacts of 200 ft-lbf (271.2 J) to a glazing specimen mounted in a frame assembly. The striking surface of the impactor shall be made from C1010–C1020 carbon steel and have a striking surface of  $4 \pm .04 \text{ in.}^2$  ( $101.6 \pm 1.016 \text{ mm}^2$ ) with rounded edges similar to a 10-lb (4.54-kg) sledge hammer head. See Fig. 2a.

6.1.3.2 *Sharp Impactor*—The sharp impactor shall consist of a hinged or pivoted system with a mass of 80 lbs (36.32 kg) capable of delivering impacts of 100 ft-lbf (135.6 J) to a glazing specimen mounted in a frame assembly. The striking surface of the impactor shall be made from C1010–C1020 carbon steel and sharpness of the impacting point similar to the end of a new fireman’s axe at the beginning of a test sequence. See Fig. 2b.

### 6.1.4 Procedure:

6.1.4.1 *Conditioning*—The panel shall be subjected to a cold soak of  $-20^\circ\text{F}$  ( $-28.89^\circ\text{C}$ ) for a period not less than 4 h, gradually reducing the surface temperature to  $-20 \pm 5^\circ\text{F}$  ( $-28.89 \pm 2.78^\circ\text{C}$ ). The nonthreat surface temperature shall be maintained at  $-20 \pm 5^\circ\text{F}$  ( $-28.89 \pm 2.78^\circ\text{C}$ ), 2 in. (50.8 mm)

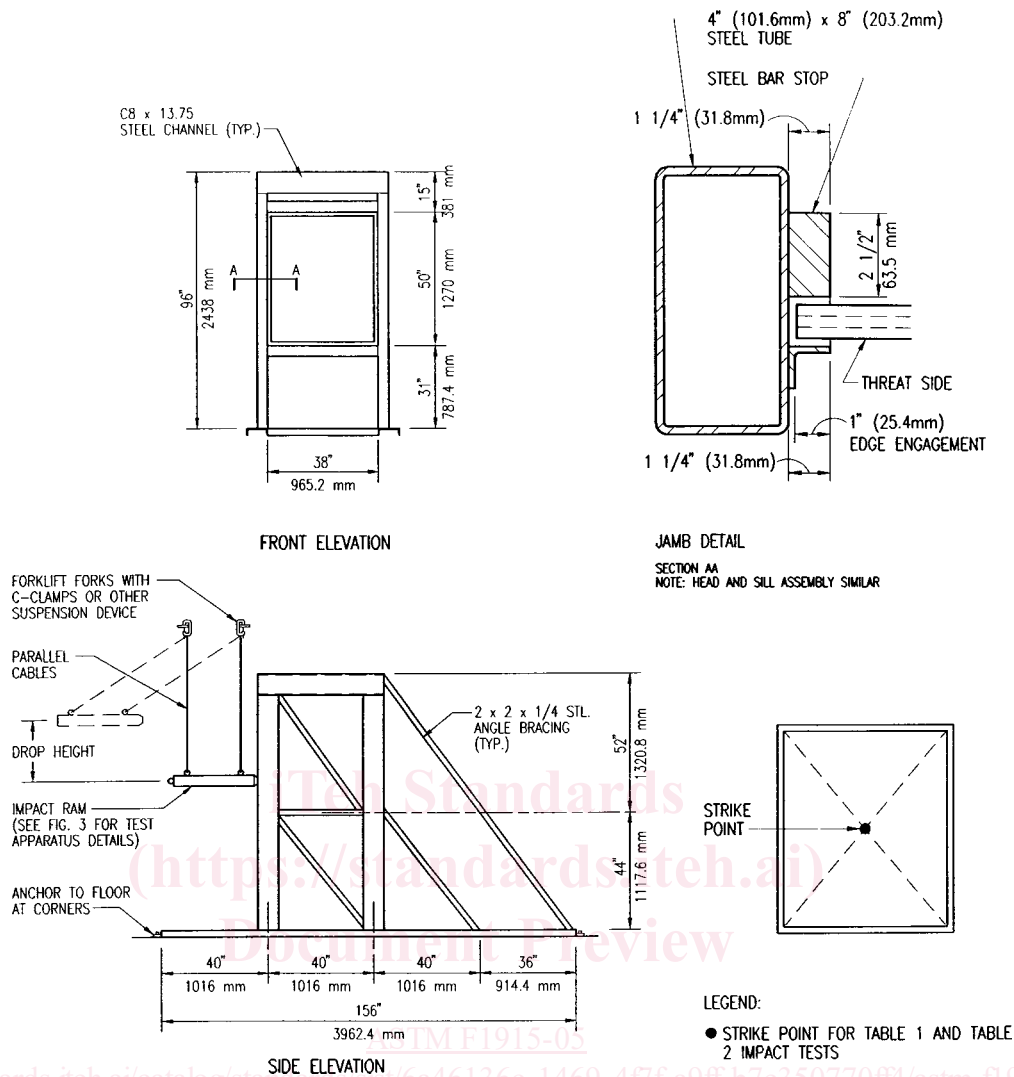

FIG. 1 Test Assembly for Detention Glazing Systems and Elevation Location of Impact Strike Point

TABLE 1 Impact Test Criteria: Large Blunt and Sharp Impactors

Security Grade	Total Time <sup>B</sup>	Sequence and Impacts <sup>A</sup>			Total Number of Impacts
		1 Blunt Impactor	2 Sharp Impactor	3 Blunt Impactor	
1	60 min	150	300	150	600
2	40 min	100	200	100	400
3	20 min	50	100	50	200
4	10 min	25	50	25	100

<sup>A</sup> To be performed on both hot and cold conditioned samples.

<sup>B</sup> See Appendix X5, Element of Time.

TABLE 2 Impact Test Criteria: Torch and Small Blunt Impactor

Security Grade	Blunt Impacts <sup>A</sup>
1	150
2	100
3	75
4	50

<sup>A</sup> To be performed on a room temperature sample only.

6.1.4.2 *Installation*—The panel shall be installed into the test fixture with a minimum 1-in. (25.4-mm) edge engagement. Appropriate gasketing material shall be used to keep glazing material from contacting frame. Refer to manufacturers recommendations.

6.1.4.3 *Procedure*—Using the test apparatus in accordance with 6.1.3, begin a series of strikes against the center of the panel for the number of required impacts, first with the blunt impactor followed by the sharp impactor on the pendulum. The strikes shall be uniformly made with 9-s intervals. Changing of blunt and sharp impactors during the test shall not exceed 90 s. During the test, reposition the pendulum as necessary to produce the maximum possible duress on the panel, leading to panel failure. Record the number of strikes required to produce the first penetration of the panel, and the number of strikes required to produce an opening large enough to pass a 5 by 8 by 8-in. (127 by 203.2 by 203.2-mm) rigid rectangular box with no more than 10 lbf (44.48 N).

6.1.5 *Test Termination*—Terminate the test after the required impacts, or when an opening in the test panel large enough to pass a 5 by 8 by 8-in. (127 by 203.2 by 203.2-mm)

from edge, during the test until an opening is created. Periodic measurements shall be taken by the test laboratory to maintain surface temperature.

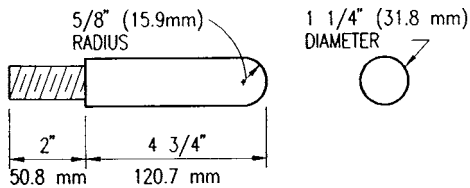

FIG. 3c Small Blunt Impactor

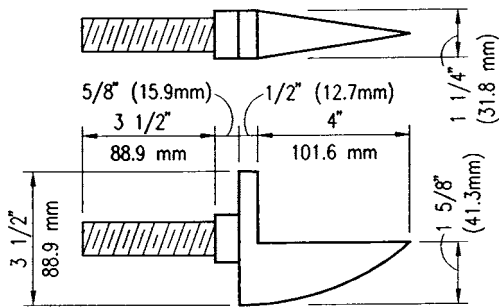

FIG. 3b Sharp Impactor

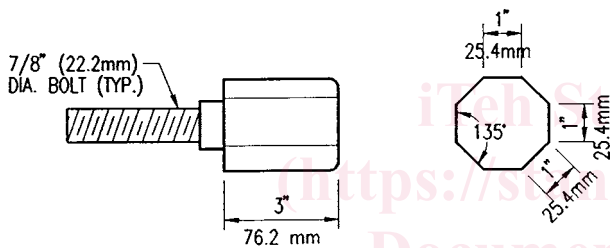

FIG. 3a Large Blunt Impactor  
FIG. 2 Test Apparatus Details

rigid rectangular box with no more than 10 lbf (44.48 N) is produced, whichever occurs first. Record the size of opening to the nearest 1/4-in. (6.35-mm), at test termination.

6.1.6 *Precision and Bias*—The precision and bias of these test methods for evaluating the impact fatigue strength of detention glazing are being determined.

6.1.7 See Table 1 for Impact Test Criteria: Large Blunt and Sharp Impactor.

6.2 *Warm Temperature Impact Test:*

6.2.1 *Scope*—These test methods are designed to evaluate the capability of detention glazing to resist repeated impact forces from both a blunt and sharp impactor under warm temperature conditions.

6.2.2 *Significance and Use*—These test methods are intended to closely simulate a sustained battering ram style or pounding type attack and provide an evaluation of the capability of the glazing to prevent, delay, or frustrate escape or access to unauthorized areas, or combination thereof, under warm temperature conditions. The test results are intended to aid in assigning a level of physical security to various configurations of detention glazing. An impact test of this design performed on detention glazing evaluates the impact strength of the glazing and its components as well as the quality of fabrication techniques.

6.2.3 *Apparatus:*

6.2.3.1 *Large Blunt Impactor*—The blunt impactor shall consist of a hinged or pivoted system with a mass of 80 lbs (36.32 kg) capable of delivering impacts of 200 ft-lbf (271.2 J) to a glazing specimen mounted in a frame assembly. The striking surface of the impactor shall be made from C1010–C1020 carbon steel and have a circular striking surface of  $4 \pm 0.04 \text{ in.}^2$  ( $101.6 \pm 1.016 \text{ mm}^2$ ) with rounded edges similar to a 10-lb (4.54-kg) sledge hammer head. See Fig. 2a.

6.2.3.2 *Sharp Impactor*—The sharp impactor shall consist of a hinged or pivoted system with a mass of 80 lbs (36.32 kg) capable of delivering impacts of 100 ft-lbf (135.6 J) to a glazing specimen mounted in a frame assembly. The striking surface of the impactor shall be made from C1010–C1020 carbon steel and sharpness of the impacting point similar to the end of a new fireman’s axe at the beginning of a test sequence. See Fig. 2b.

6.2.4 *Procedure:*

6.2.4.1 *Conditioning*—The panel shall be subjected to a heat soak of 120°F (48.9°C) for a period not less than 4 h, gradually increasing the surface temperature to  $120 \pm 5^\circ\text{F}$  ( $48.9 \pm 2.78^\circ\text{C}$ ). The nonthreat surface temperature shall be maintained at  $120 \pm 5^\circ\text{F}$  ( $48.9 \pm 2.78^\circ\text{C}$ ), 2 in. (50.8 mm) from edge, during the test until an opening is created. Periodic measurements shall be taken by the test laboratory to maintain surface temperature.

6.2.4.2 *Installation*—The panel shall be installed into the test fixture with a minimum 1-in. (25.4-mm) edge engagement. Appropriate gasketing material shall be used to keep glazing material from contacting frame. Refer to manufacturer’s recommendations.

6.2.4.3 *Procedure*—Using the test apparatus in accordance with 6.2.3, begin a series of strikes against the center of the panel, for the number of required impacts first with the blunt impactor followed by the sharp impactor on the pendulum. The strikes shall be uniformly made with 9-s intervals. Changing of blunt and sharp impactors during the test shall not exceed 90 s. During the test, reposition the pendulum as necessary to produce the maximum possible duress on the panel, enlarging the opening and leading to panel failure. Record the number of strikes required to produce the first penetration of the panel, and the number of strikes required to produce an opening large enough to pass a 5 by 8 by 8-in. (127 by 203.2 by 203.2-mm) rigid rectangular box with no more than 10 lbf (44.48 N).

6.2.5 *Test Termination*—Terminate the test after the required impacts, or when an opening in the test panel large enough to pass a 5 by 8 by 8-in. (127 by 203.2 by 203.2-mm) rigid rectangular box with no more than 10 lbf (44.48 N) is produced, whichever occurs first. Record the size of penetration, to the nearest 1/4-in. (6.35-mm), at test termination.

6.2.6 *Precision and Bias*—The precision and bias of this test method for evaluating the impact fatigue strength of detention glazing is being determined.

6.2.7 See Table 1 for impact test criteria for large blunt impactor and sharp impactors.

6.3 *Torch and Small Blunt Impactor Test:*