



SLOVENSKI STANDARD
oSIST prEN ISO 9151:2014
01-februar-2014

Varovalna obleka pred učinki toplote in ognja - Določanje prenosa toplote pri izpostavljenosti plamenu (ISO/DIS 9151:2013)

Protective clothing against heat and flame - Determination of heat transmission on exposure to flame (ISO/DIS 9151:2013)

Schutzkleidung gegen Hitze und Flammen - Bestimmung des Wärmedurchgangs bei Flammeneinwirkung (ISO/DIS 9151:2013)

Vêtements de protection contre la chaleur et les flammes - Détermination de la transmission de chaleur à l'exposition d'une flamme (ISO/DIS 9151:2013)

Ta slovenski standard je istoveten z: prEN ISO 9151

ICS:

13.340.10 Varovalna obleka Protective clothing

oSIST prEN ISO 9151:2014 **en,fr,de**

DRAFT INTERNATIONAL STANDARD

ISO/DIS 9151

ISO/TC 94/SC 13

Secretariat: SNV

Voting begins on:
2013-12-12Voting terminates on:
2014-05-12

Protective clothing against heat and flame — Determination of heat transmission on exposure to flame

Vêtements de protection contre la chaleur et les flammes — Détermination de la transmission de chaleur à l'exposition d'une flamme

[Revision of first edition (ISO 9151:1995)]

ICS: 13.340.10

iTeh STANDARD PREVIEW
(standards.iteh.ai)

[SIST EN ISO 9151:2017](https://standards.iteh.ai/catalog/standards/sist/3aa1d90f-a347-47ae-9419-26b969db50e5/sist-en-iso-9151-2017)

<https://standards.iteh.ai/catalog/standards/sist/3aa1d90f-a347-47ae-9419-26b969db50e5/sist-en-iso-9151-2017>

ISO/CEN PARALLEL PROCESSING

This draft has been developed within the International Organization for Standardization (ISO), and processed under the **ISO lead** mode of collaboration as defined in the Vienna Agreement.

This draft is hereby submitted to the ISO member bodies and to the CEN member bodies for a parallel five month enquiry.

Should this draft be accepted, a final draft, established on the basis of comments received, will be submitted to a parallel two-month approval vote in ISO and formal vote in CEN.

To expedite distribution, this document is circulated as received from the committee secretariat. ISO Central Secretariat work of editing and text composition will be undertaken at publication stage.

THIS DOCUMENT IS A DRAFT CIRCULATED FOR COMMENT AND APPROVAL. IT IS THEREFORE SUBJECT TO CHANGE AND MAY NOT BE REFERRED TO AS AN INTERNATIONAL STANDARD UNTIL PUBLISHED AS SUCH.

IN ADDITION TO THEIR EVALUATION AS BEING ACCEPTABLE FOR INDUSTRIAL, TECHNOLOGICAL, COMMERCIAL AND USER PURPOSES, DRAFT INTERNATIONAL STANDARDS MAY ON OCCASION HAVE TO BE CONSIDERED IN THE LIGHT OF THEIR POTENTIAL TO BECOME STANDARDS TO WHICH REFERENCE MAY BE MADE IN NATIONAL REGULATIONS.

RECIPIENTS OF THIS DRAFT ARE INVITED TO SUBMIT, WITH THEIR COMMENTS, NOTIFICATION OF ANY RELEVANT PATENT RIGHTS OF WHICH THEY ARE AWARE AND TO PROVIDE SUPPORTING DOCUMENTATION.



Reference number
ISO/DIS 9151:2013(E)

© ISO 2013

iTeh STANDARD PREVIEW
(standards.iteh.ai)

SIST EN ISO 9151:2017

<https://standards.iteh.ai/catalog/standards/sist/3aa1d90f-a347-47ae-9419-26b969db50e5/sist-en-iso-9151-2017>

Copyright notice

This ISO document is a Draft International Standard and is copyright-protected by ISO. Except as permitted under the applicable laws of the user's country, neither this ISO draft nor any extract from it may be reproduced, stored in a retrieval system or transmitted in any form or by any means, electronic, photocopying, recording or otherwise, without prior written permission being secured.

Requests for permission to reproduce should be addressed to either ISO at the address below or ISO's member body in the country of the requester.

ISO copyright office
Case postale 56 • CH-1211 Geneva 20
Tel. + 41 22 749 01 11
Fax + 41 22 749 09 47
E-mail copyright@iso.org
Web www.iso.org

Reproduction may be subject to royalty payments or a licensing agreement.

Violators may be prosecuted.

Contents

Page

Foreword	iv
Introduction.....	v
1 Scope.....	1
2 Normative references.....	1
3 Definitions	1
4 Principle	1
5 Apparatus	2
5.1 Gas burner.....	2
5.2 Copper disc calorimeter and mounting block.....	2
5.3 Specimen support frame	4
5.4 Calorimeter location plate	4
5.5 Support stand	6
5.6 Recorder	7
5.7 Flat rigid template.....	7
6 Precautions	7
7 Sampling	8
7.1 Specimen dimensions.....	8
7.2 Number of specimens	8
8 Conditioning and testing atmospheres.....	8
8.1 Conditioning atmosphere.....	8
8.2 Testing atmosphere	8
9 Test procedure.....	8
9.1 Preparation and calibration	8
9.1.1 Preliminary procedures	8
9.1.2 Regulation of the exposure heat flux	8
9.2 Test specimen mounting	10
9.3 Test specimen exposure.....	10
10 Test report.....	11
Annex A (informative) Availability of materials.....	12
Annex B (informative) Specimen test report form	13
Annex C (informative) Significance of the heat transfer test.....	14
Annex ZA (informative) Relationship between this European Standard and the Essential Requirements of EU Directive 89/686/ECC	16

ISO/DIS 9151

Foreword

ISO (the International Organization for Standardization) is a worldwide federation of national standards bodies (ISO member bodies). The work of preparing International Standards is normally carried out through ISO technical committees. Each member body interested in a subject for which a technical committee has been established has the right to be represented on that committee. International organizations, governmental and non-governmental, in liaison with ISO, also take part in the work. ISO collaborates closely with the International Electrotechnical Commission (IEC) on all matters of electrotechnical standardization.

International Standards are drafted in accordance with the rules given in the ISO/IEC Directives, Part 2.

The main task of technical committees is to prepare International Standards. Draft International Standards adopted by the technical committees are circulated to the member bodies for voting. Publication as an International Standard requires approval by at least 75 % of the member bodies casting a vote.

Attention is drawn to the possibility that some of the elements of this document may be the subject of patent rights. ISO shall not be held responsible for identifying any or all such patent rights.

ISO 9151 was prepared by Technical Committee ISO/TC 94, *Personal safety -- Protective clothing and equipment*, Subcommittee SC 13, and by Technical Committee CEN/TC 162, *Protective clothing including hand and arm protection and lifejackets* in collaboration.

This second edition cancels and replaces the first edition (ISO 9151:1995), of which subclauses 5.1, 5.2, 7.2, 9.1.2, 9.3.2, all figures, and annexes A and B have been technically revised.

Annexes A, B and C of this International Standard are for information only.

[SIST EN ISO 9151:2017](https://standards.iteh.ai/catalog/standards/sist/3aa1d90f-a347-47ae-9419-26b969db50e5/sist-en-iso-9151-2017)

<https://standards.iteh.ai/catalog/standards/sist/3aa1d90f-a347-47ae-9419-26b969db50e5/sist-en-iso-9151-2017>

Introduction

Heat transmission through clothing is largely determined by its thickness including any air gaps trapped between the different layers. The air gaps can vary considerably in different areas of the same clothing assembly. The present method provides a grading of materials when tested under standard test conditions without an air gap.

This second edition of ISO 9151 cancels and replaces ISO 9151:1995. To improve reproducibility, the following major modifications have been made from the previous version of this test method:

- a) A specification of the propane has been provided (para 5.1)
- b) Additional instructions are given for inserting the calorimeter into the mounting block (para 5.2)
- c) The number of specimens to be tested has been increased from three to five (para 7.2)
- d) The temperature of the testing atmosphere has been somewhat limited (para 8.2)
- e) A procedure to check on the linearity of the thermocouple output during regulation of the incident heat flux density has been added (para 9.1.2)
- f) Tolerances for the dimensions of machined parts have been added to text and drawings where required.

(standards.iteh.ai)

[SIST EN ISO 9151:2017](https://standards.iteh.ai/catalog/standards/sist/3aa1d90f-a347-47ae-9419-26b969db50e5/sist-en-iso-9151-2017)

<https://standards.iteh.ai/catalog/standards/sist/3aa1d90f-a347-47ae-9419-26b969db50e5/sist-en-iso-9151-2017>

Protective clothing against heat and flame — Determination of heat transmission on exposure to flame

1 Scope

This International Standard specifies a method for comparing the heat transmission through materials or material assemblies used in protective clothing. Materials are ranked by calculation of a heat transfer index, which is an indication of the relative heat transmission under the specified test conditions. The heat transfer index should not be taken as a measure of the protection time given by the tested materials under actual use conditions.

2 Normative references

The following standards contain provisions which, through reference in this text, constitute provisions of this International Standard. At the time of publication, the editions indicated were valid. All standards are subject to revision, and parties to agreements based on this International Standard are encouraged to investigate the possibility of applying the most recent editions of the standards indicated below. Members of IEC and ISO maintain registers of currently valid International Standards.

ISO 139, *Textiles - Standard atmospheres for conditioning and testing*.

ISO 9162, *Petroleum products – Fuel (class F) – Liquefied petroleum gases - Specifications*

IEC 60584-1, *Thermocouples - Part 1: Reference tables*.

3 Definitions

For the purposes of this document, the following definitions apply.

3.1

test specimen

all the layers of fabric or other materials arranged in the order and orientation as used in practice, including, where applicable, undergarment fabrics.

3.2

incident heat flux

amount of energy incident per unit time on the exposed face of the specimen, expressed in kilowatts per square metre (kW/m^2).

3.3

heat transfer index (flame)

whole number calculated from the mean time in seconds to achieve a temperature rise of $(24 \pm 0,2)$ °C when testing by this method using a copper disc of mass $(18 \pm 0,05)$ g and a starting temperature of (25 ± 5) °C.

4 Principle

A horizontally oriented test specimen is partially restrained from moving and subjected to an incident heat flux of 80 kW/m^2 from the flame of a gas burner placed beneath it. The heat passing through the specimen is measured by means of a small copper calorimeter on top of and in contact with the specimen. The time, in seconds, for the temperature in the calorimeter to rise $(24 \pm 0,2)$ °C is recorded. The mean result for five test specimens is calculated as the "heat transfer index (flame)".

ISO/DIS 9151

5 Apparatus

The apparatus consists of

- a gas burner;
- a copper disc calorimeter;
- a specimen support frame;
- a calorimeter location plate;
- a support stand;
- suitable measuring equipment;
- a template.

5.1 Gas burner.

A flat topped Meker burner with a perforated top area of (38 ± 2) mm diameter and a jet suitable for propane gas shall be used. (See Annex A for possible sources.)

Commercial grade propane of 95 % minimum purity [see ISO 9162] shall be used with the flow being controlled by a fine control valve and flow meter.

5.2 Copper disc calorimeter and mounting block

Copper disc calorimeter, consisting of a disc of copper of at least 99 % purity, having a diameter of (40 ± 0.05) mm and thickness 1,6 mm, and a mass of $(18 \pm 0,05)$ g. The disc shall be accurately weighed before assembly.

The calorimeter shall be constructed as indicated in Figure 1. Type T – 36 gauge (insulated copper-constantan thermocouple wire) shall be used, with the constantan wire inserted into a predrilled hole in the centre of the calorimeter and soldered in place with a minimum of solder. The copper wire shall be attached in the same manner, 15-18 mm from the centre, so as not to interfere with the seating of disc in the mounting block.

The calorimeter is located in a mounting block which shall consist of a 89 mm diameter circular piece of asbestos-free non-combustible heat insulating board (See Annex A) of nominal thickness 13 mm (see Figure 2). The thermal characteristics shall comply with the following specification:

Density	(750 ± 50) kg/m ³
Thermal conductivity	0,18 W/(m·K) ± 10 %

A circular cavity is machined in the centre of the block to accommodate the disc and an air gap as shown in Figure 2. The disc is held in position using small stainless steel pins (0,45 mm diameter or less) which protrude through the back of the insulating block with sufficient length that they can be used to secure the disk (see Figure 3). The mounting pins shall be stainless steel, soft soldered to the calorimeter using the minimum quantity of solder necessary.

The face of the copper disc shall be flush with the surface of the mounting block. It shall also be coated with a thin layer of an optically black paint having a coefficient of absorption, α , greater than 0,9 (see Annex A).

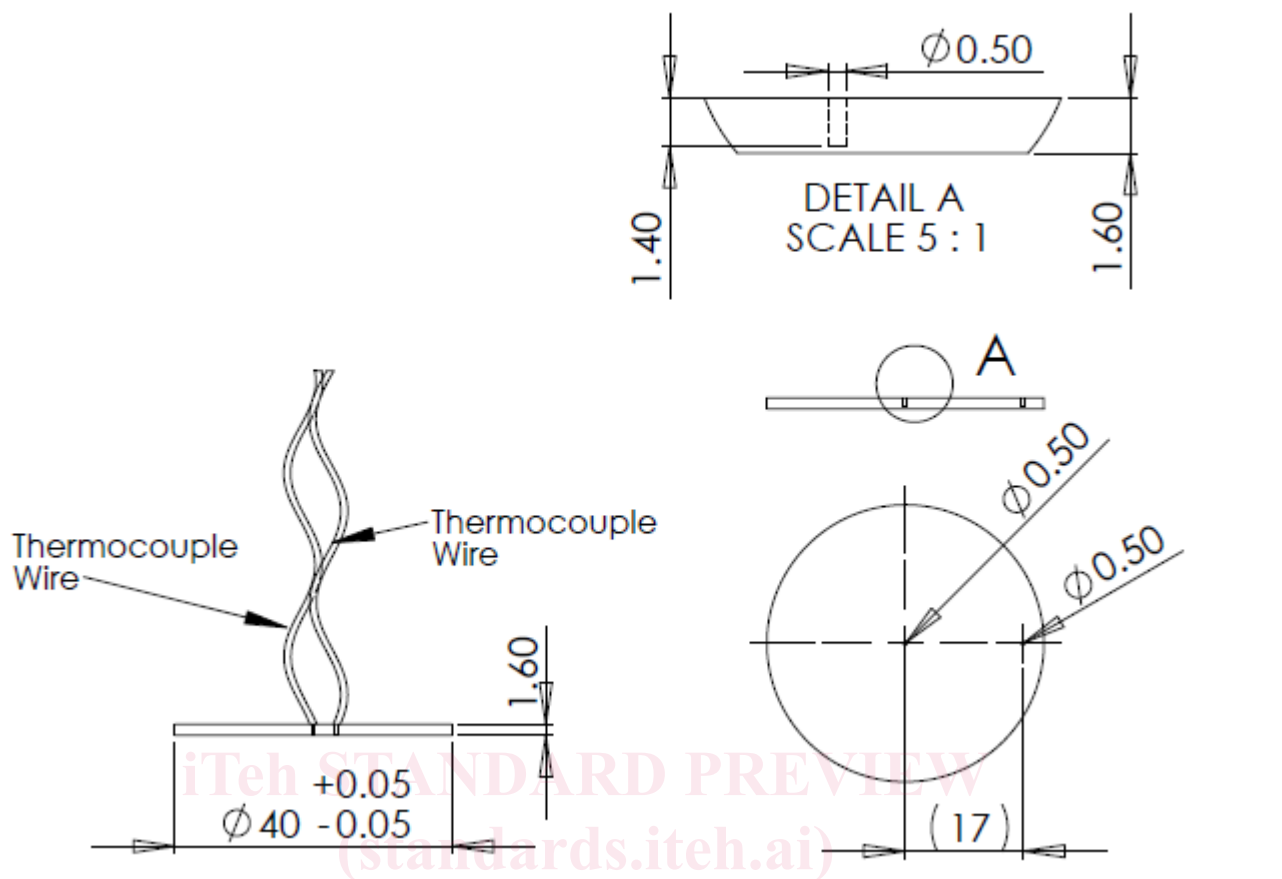

a) calorimeter assembly with mounting pins omitted for clarity

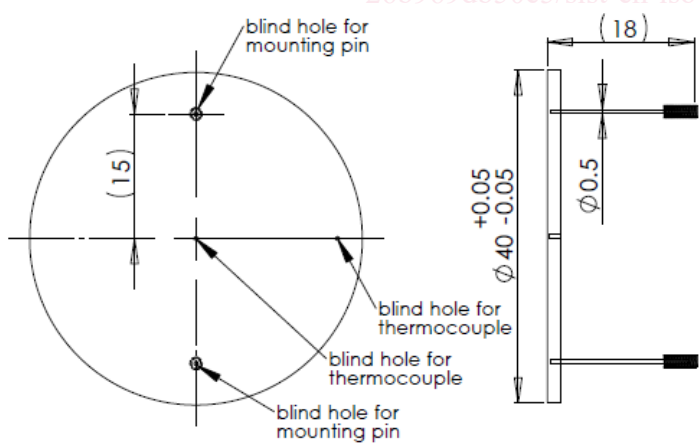

b) copper calorimeter showing location of mounting pins (thermocouple wires omitted for clarity)

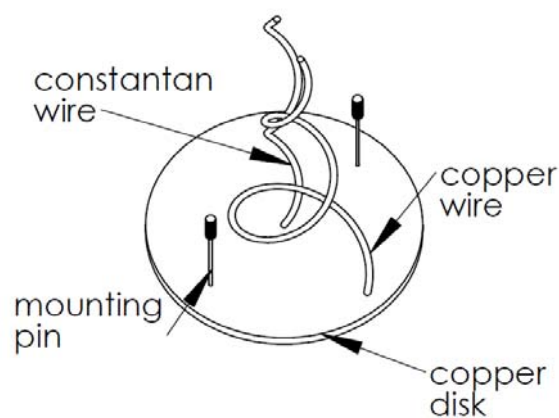

c) copper calorimeter assembly

Figure 1 — Copper calorimeter (all dimensions in mm)