

Foreword

ISO (the International Organization for Standardization) is a worldwide federation of national standards bodies (ISO member bodies). The work of developing International Standards is carried out through ISO technical committees. Every member body interested in a subject for which a technical committee has been authorized has the right to be represented on that committee. International organizations, governmental and non-governmental, in liaison with ISO, also take part in the work.

Draft International Standards adopted by the technical committees are circulated to the member bodies for approval before their acceptance as International Standards by the ISO Council.

International Standard ISO 133 was developed by Technical Committee ISO/TC 45, *Rubber and rubber products*.

This third edition was submitted directly to the ISO Council, in accordance with clause 6.11.2 of part 1 of the Directives for the technical work of ISO. It cancels and replaces the second edition (i.e. ISO 133-1981), which had been approved by the member bodies of the following countries:

| | | |
|---------------------|-----------------------|----------------|
| Austria | Netherlands | Switzerland |
| Canada | New Zealand | Turkey |
| Egypt, Arab Rep. of | Poland | United Kingdom |
| France | Romania | USA |
| Germany, F. R. | South Africa, Rep. of | USSR |
| Hungary | Spain | Yugoslavia |
| India | Sri Lanka | |
| Italy | Sweden | |

No member body had expressed disapproval of the document.

Rubber, vulcanized — Determination of crack growth (De Mattia)

0 Introduction

Repeated bending or flexing of a rubber vulcanizate causes cracks to develop in that part of the surface where tension stress is set up during flexing or, if this part of the surface contains a crack or cut, causes this to extend in a direction perpendicular to the stress. Certain soft vulcanizates, notably those prepared from styrene-butadiene rubber, show marked resistance to crack initiation, but it is possible for these vulcanizates to have a low resistance to growth (propagation) of cracks or cuts. It is important, therefore, to measure both the resistance to crack initiation by flexing and the resistance to crack propagation. A method for determining the resistance to crack initiation by flexing is given in ISO 132.

NOTE — The presence of significant amounts of ozone in the laboratory atmosphere affects the results. Periodic checks are advised in order to ensure that the ambient ozone concentration is preferably less than 1 ppm (part per 100 million) parts of air.

1 Scope and field of application

This International Standard specifies a method of test intended for use in comparing the resistance of rubbers to the growth of cracks, when subjected to repeated flexing on the De Mattia-type machine. For this purpose, a prescribed cut is made in the test piece to initiate cut growth.

2 References

ISO 132, *Rubber, vulcanized — Determination of flex cracking (De Mattia)*.

ISO 471, *Rubber — Standard temperatures, humidities and times for the conditioning and testing of test pieces*.

ISO 1826, *Rubber, vulcanized — Time-interval between vulcanization and testing — Specification*.

ISO 3383, *Rubber — General directions for achieving elevated or subnormal temperatures for test purposes*.¹⁾

3 Apparatus

The essential features of the De Mattia-type machine are as follows :

Stationary parts, provided with grips for holding one end of each of the test pieces in a fixed position, and similar but

reciprocating parts for holding the other end of each of the test pieces. The travel is $57 + 0,5$ mm and is such that the maximum distance between each set of opposing grips is $75 + 1$ mm (see figure 1).

The reciprocating parts are so arranged that their motion is straight, and in the direction of, and in the same plane as, the common centre line of each opposing pair of grips. The planes of the gripping surfaces of each opposing pair of grips remain parallel throughout the motion.

The eccentric which actuates the reciprocating parts is driven by a constant-speed motor to give $5,00 \pm 0,17$ Hz, with sufficient power to flex at least six, and preferably twelve, test pieces at one test. The grips hold the test pieces firmly, without undue compression, and enable individual adjustment to be made to the test pieces to ensure accurate insertion.

For testing at elevated temperatures, the machine may be enclosed in a chamber with temperature control near the centre of the test piece to ± 2 °C, if necessary, by using an air circulator.

NOTE — It is useful to arrange the test pieces in two equal groups, so that one group is being flexed while the other group is being straightened, thus reducing the vibration in the machine.

4 Test piece

4.1 Form and dimensions

The test piece shall be a strip with a moulded groove, as shown in figure 2. The strips may be moulded individually in a multiple-cavity mould or may be cut from a wide slab having a moulded groove.

The groove in the test piece shall have a smooth surface and shall be free from irregularities from which cracks may start prematurely. The groove shall be moulded into the test piece or slab by a half-round ridge in the centre of the cavity. This half-round ridge shall have a radius of $2,38 \pm 0,03$ mm. The moulded groove shall be perpendicular to the direction of calendaring.

The results shall be compared only between test pieces having thicknesses agreeing within the tolerances, when measured close to the groove, because the results of the test are dependent upon the thickness of the test piece.

1) At present at the stage of draft. (Revision of ISO 3383-1976.)

4.2 Time interval between vulcanization and testing

For all test purposes, the minimum time between vulcanization and testing shall be 16 h in accordance with ISO 1826.

For non-product tests, the maximum time between vulcanization and testing shall be 4 weeks, and for evaluations intended to be comparable, the tests, as far as possible, should be carried out after the same time interval.

As far as possible, samples and test pieces shall be kept away from exposure to light.

4.3 Conditioning

For tests at a standard laboratory temperature (see clause 6) : individually moulded test pieces, after preparation as necessary, shall be conditioned at the test temperature for a minimum of 3 h immediately before testing, the same test temperature being used throughout any test or series of tests intended to be comparable. Slab samples shall be similarly conditioned before the test pieces are cut.

For tests at other temperatures (see clause 6) : after the conditioning period specified above, the test pieces shall be brought to the test temperature by keeping in a chamber at this temperature for 3 h, then tested immediately. (See ISO 3383.)

4.4 Number of test pieces

At least three, and preferably six, test pieces from each rubber compound shall be tested, and the results averaged, one or more test pieces being tested simultaneously with those of other rubbers with which the comparison is to be made.

4.5 Preparation

Each test piece shall be prepared by piercing the bottom of the groove at a point equidistant from the sides, using a suitable jig. The piercing tool shall be maintained perpendicular to both the transverse and longitudinal axes, and the cut accomplished by a single insertion and withdrawal of the tool. The cut shall be parallel to the longitudinal axis of the groove. Lubrication with water containing a suitable wetting agent may be used.

A suitable jig shall be provided to hold the cutting tool; the exact details are not specified but the principles of operation should be as follows :

The test piece shall be held flat in a solid support. The cutting tool shall be normal to the support and placed centrally with respect to the groove of the test piece, with the cutting edge of the piercing tool parallel to the axis of the groove. Means shall be provided for passing the cutting tool through the entire thickness of the rubber, and the support shall have a hole of a size just sufficient to permit the cutting tool to project through the base of the test piece to not less than 2,5 mm and not more than 3 mm.

The piercing tool shall conform to the dimensions given in figure 3.

5 Procedure

Measure the initial length of the cut, L , preferably using a low-powered magnifying glass.

Separate the pairs of grips to their maximum extent, and insert the test pieces so that they are flat and not under tension, with the groove in any particular test piece midway between the two grips in which that test piece is held, and on the outside of the angle made by the test piece when it is bent.

Start the machine and stop it at frequent intervals to measure the length of the cut, for example at the 1, 3 and 5 kilocycle periods and at such further or intermediate periods as appear necessary. At each observation, separate the grips to a distance of 65 mm and measure the length of the cut, preferably using a low-powered magnifying glass. From the smooth curve obtained by plotting length against number of flexing cycles, take readings of

- a) the number of kilocycles for the cut to extend from L to $(L + 2)$ mm;
- b) the number of kilocycles for the cut to extend from $(L + 2)$ to $(L + 6)$ mm;
- c) if desired, the number of kilocycles for the cut to extend from $(L + 6)$ to $(L + 10)$ mm.

The test shall not be made in a room which contains any apparatus that generates ozone, such as a fluorescent lamp, or which for any reason has an ozone content above that in normal indoor air. The motor used to drive the test machine shall be of a type that does not generate ozone.

6 Temperature of test

Tests are normally performed at standard laboratory temperatures as defined in ISO 471, although elevated temperatures may often be used with advantage. In the latter case, the test temperature shall be one of the preferred temperatures, 40, 55, 70, 85, 100, 125, 150 °C.

7 Test report

The test report shall contain the following information :

- a) a reference to this International Standard;
- b) the number of kilocycles for the cut to extend from L to $(L + 2)$ mm;
- c) the number of kilocycles for the cut to extend from $(L + 2)$ to $(L + 6)$ mm;
- d) if desired, the number of kilocycles for the cut to extend from $(L + 6)$ to $(L + 10)$ mm;
- e) the number of test pieces used;
- f) the temperature of test.

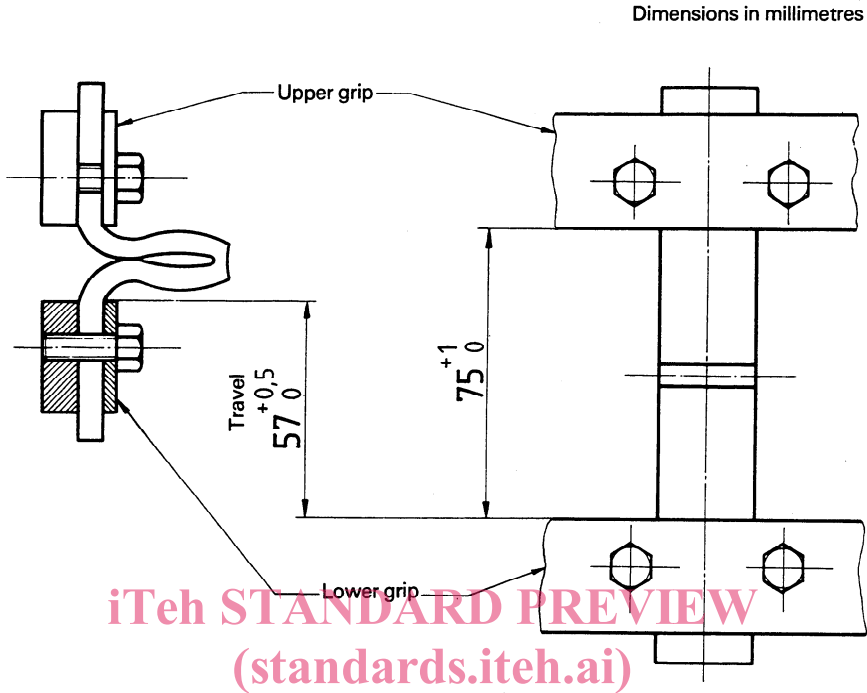

Figure 1 — De Mattia-type machine
<https://standards.iteh.ai/catalog/standards/sist/db2b159a-24e2-4674-b565-a5b00afb6bea/iso-133-1983>

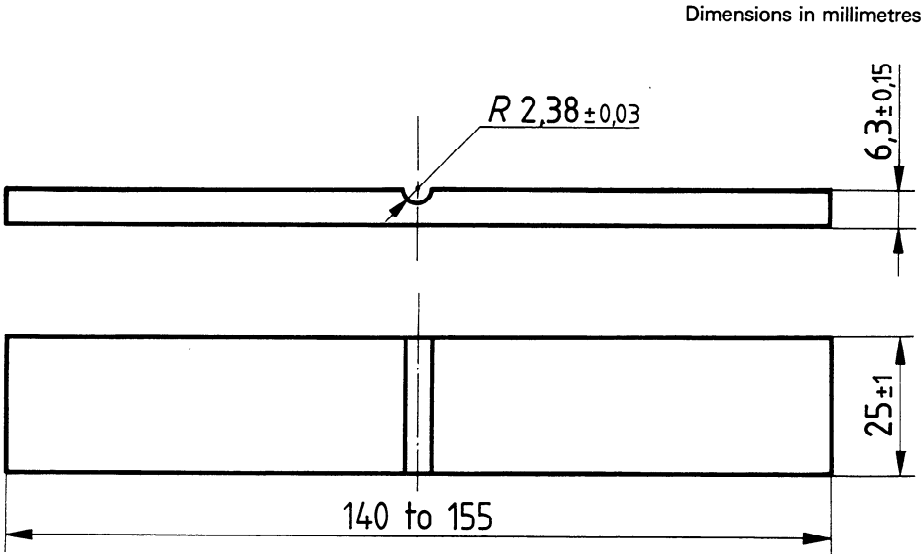

Figure 2 — Test piece

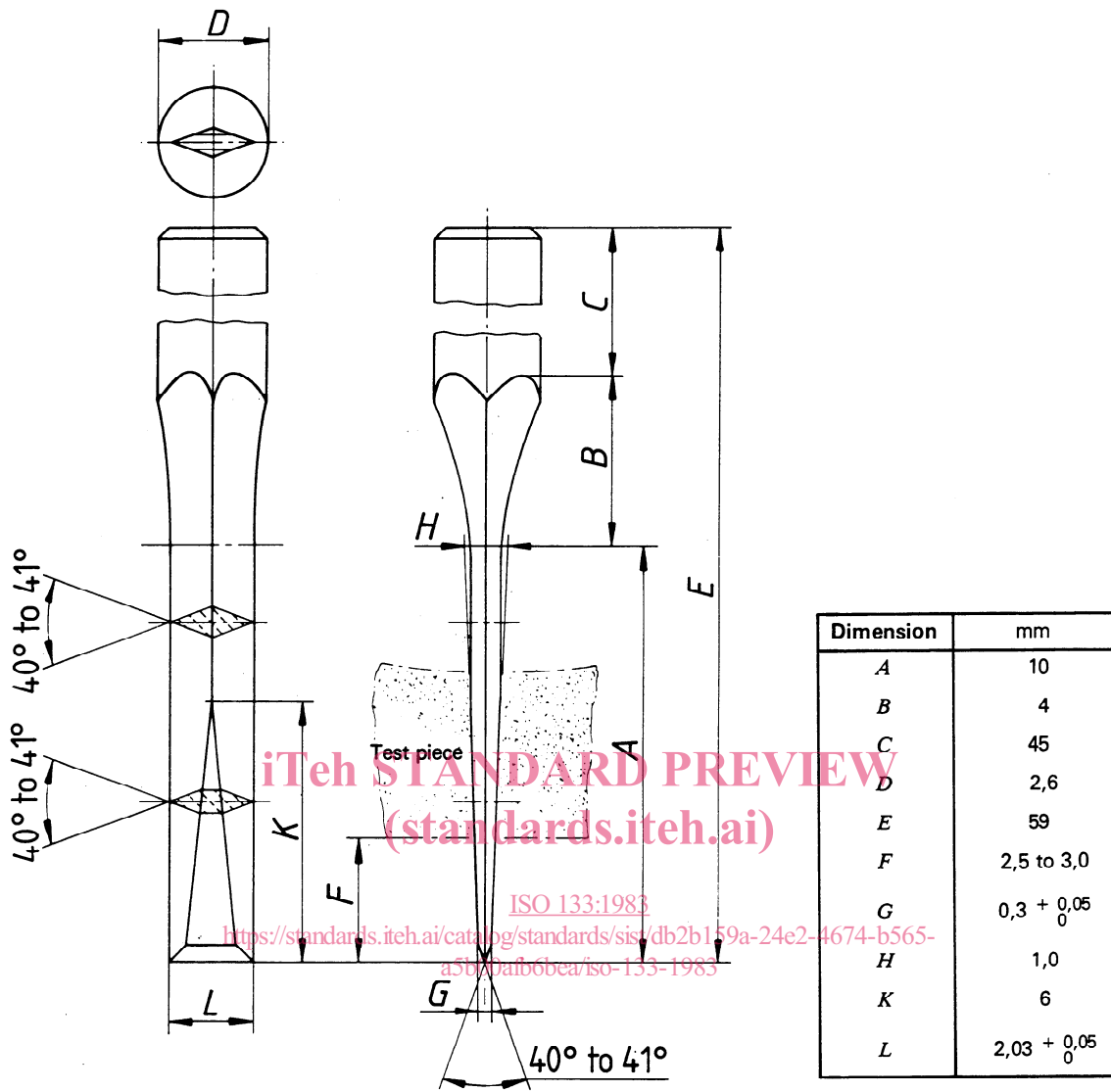

Figure 3 — Piercing tool