



SLOVENSKI STANDARD

SIST EN 4156:2014

01-marec-2014

Aeronavtika - Ušesne glave (vrhovi palic) s samoporavnavnimi (nihalnimi) dvorednimi krogličnimi ležaji in držaji z navoji iz jekla - Notranji obroč in kroglice iz korozijsko odpornega jekla - Dimenzije in obremenitve - Colska izvedba

Aerospace series - Rod ends, with self-aligning double row ball bearings and threaded shank in steel - Inner ring and balls in corrosion resisting steel - Dimensions and loads - Inch series

Luft- und Raumfahrt - Ösenköpfe mit zweireihigem Pendelkugellager und Gewindeschaft aus Stahl - Innenring und Wälzkörper aus korrosionsbeständigem Stahl - Maße und Belastungen - Zoll Reihe

[SIST EN 4156:2014](https://standards.iteh.ai/catalog/standards/sist/acc92b9b-25d0-4d0a-987c-1f2e30303030)

Série aérospatiale - Embouts à rotule sur deux rangées de billes et à tige filetée en acier - Bague intérieure et billes en acier résistant à la corrosion - Dimensions et charges - Série en inches

Ta slovenski standard je istoveten z: EN 4156:2013

ICS:

49.025.10	Jekla	Steels
49.035	Sestavni deli za letalsko in vesoljsko gradnjo	Components for aerospace construction

SIST EN 4156:2014

en,fr,de

iTeh STANDARD PREVIEW
(standards.iteh.ai)

[SIST EN 4156:2014](#)

<https://standards.iteh.ai/catalog/standards/sist/acc92b9b-25d0-4d0a-987c-5917e361052e/sist-en-4156-2014>

EUROPEAN STANDARD

EN 4156

NORME EUROPÉENNE

EUROPÄISCHE NORM

December 2013

ICS 49.035

English Version

Aerospace series - Rod ends, with self-aligning double row ball bearings and threaded shank in steel - Inner ring and balls in corrosion resisting steel - Dimensions and loads - Inch series

Série aérospatiale - Embouts à rotule sur deux rangées de billes et à tige filetée en acier - Bague intérieure et billes en acier résistant à la corrosion - Dimensions et charges - Série en inches

Luft- und Raumfahrt - Ösenköpfe mit zweireihigem Pendelkugellager und Gewindeschaff aus Stahl - Innenring und Wälzkörper aus korrosionsbeständigem Stahl - Maße und Belastungen - Zoll Reihe

This European Standard was approved by CEN on 21 March 2013.

CEN members are bound to comply with the CEN/CENELEC Internal Regulations which stipulate the conditions for giving this European Standard the status of a national standard without any alteration. Up-to-date lists and bibliographical references concerning such national standards may be obtained on application to the CEN-CENELEC Management Centre or to any CEN member.

This European Standard exists in three official versions (English, French, German). A version in any other language made by translation under the responsibility of a CEN member into its own language and notified to the CEN-CENELEC Management Centre has the same status as the official versions.

CEN members are the national standards bodies of Austria, Belgium, Bulgaria, Croatia, Cyprus, Czech Republic, Denmark, Estonia, Finland, Former Yugoslav Republic of Macedonia, France, Germany, Greece, Hungary, Iceland, Ireland, Italy, Latvia, Lithuania, Luxembourg, Malta, Netherlands, Norway, Poland, Portugal, Romania, Slovakia, Slovenia, Spain, Sweden, Switzerland, Turkey and United Kingdom.



EUROPEAN COMMITTEE FOR STANDARDIZATION
COMITÉ EUROPÉEN DE NORMALISATION
EUROPÄISCHES KOMITEE FÜR NORMUNG

CEN-CENELEC Management Centre: Avenue Marnix 17, B-1000 Brussels

Contents

Page

Foreword.....	3
1 Scope	4
2 Normative references	4
3 Symbols and definitions	5
4 Required characteristics	5
5 Qualification	11
6 Designation	11
7 Marking	11
8 Technical specification	11

iTeh STANDARD PREVIEW
(standards.iteh.ai)

[SIST EN 4156:2014](https://standards.iteh.ai/catalog/standards/sist/acc92b9b-25d0-4d0a-987c-5917e361052e/sist-en-4156-2014)

<https://standards.iteh.ai/catalog/standards/sist/acc92b9b-25d0-4d0a-987c-5917e361052e/sist-en-4156-2014>

Foreword

This document (EN 4156:2013) has been prepared by the Aerospace and Defence Industries Association of Europe - Standardization (ASD-STAN).

After enquiries and votes carried out in accordance with the rules of this Association, this Standard has received the approval of the National Associations and the Official Services of the member countries of ASD, prior to its presentation to CEN.

This European Standard shall be given the status of a national standard, either by publication of an identical text or by endorsement, at the latest by June 2014, and conflicting national standards shall be withdrawn at the latest by June 2014.

Attention is drawn to the possibility that some of the elements of this document may be the subject of patent rights. CEN [and/or CENELEC] shall not be held responsible for identifying any or all such patent rights.

According to the CEN-CENELEC Internal Regulations, the national standards organizations of the following countries are bound to implement this European Standard: Austria, Belgium, Bulgaria, Croatia, Cyprus, Czech Republic, Denmark, Estonia, Finland, Former Yugoslav Republic of Macedonia, France, Germany, Greece, Hungary, Iceland, Ireland, Italy, Latvia, Lithuania, Luxembourg, Malta, Netherlands, Norway, Poland, Portugal, Romania, Slovakia, Slovenia, Spain, Sweden, Switzerland, Turkey and the United Kingdom.

ITEH STANDARD PREVIEW
(standards.iteh.ai)

[SIST EN 4156:2014](https://standards.iteh.ai/catalog/standards/sist/acc92b9b-25d0-4d0a-987c-5917e361052e/sist-en-4156-2014)

<https://standards.iteh.ai/catalog/standards/sist/acc92b9b-25d0-4d0a-987c-5917e361052e/sist-en-4156-2014>

EN 4156:2013 (E)**1 Scope**

This European Standard specifies the characteristics of adjustable rod ends with self-aligning double row ball bearing and threaded shank in steel, inner ring and balls in corrosion resisting steel.

They consist of:

- a rod end comprising:
 - either seals or shields;
 - an optional longitudinal groove for locking purpose;
- an inner ring with balls.

These rod ends are intended for use with flight control rods or rods for aerospace structures.

They are intended to be used in the temperature range: – 54 °C to 150 °C.

However, being lubricated with the following greases:

- very high pressure grease, ester type (code A), operational range – 73 °C to 121 °C according MIL-PRF-23827 type II
- very high pressure grease, synthetic hydrocarbons, general purpose (code B), operational range – 54 °C to 177 °C (see EN 2067), according MIL-PRF-81322.
- very high pressure grease, lithium type (code C) operational range – 73 °C to 121 °C according MIL-PRF-23827 type I.

Their field of application when lubricated with codes A and C grease is limited to 121 °C.

2 Normative references

The following documents, in whole or in part, are normatively referenced in this document and are indispensable for its application. For dated references, only the edition cited applies. For undated references, the latest edition of the referenced document (including any amendments) applies.

EN 2030, *Aerospace series — Steel FE-PM3501 (X105CrMo17) — Hardened and tempered — Bars $D \leq 150$ mm*

EN 2067, *Aerospace series — Rod ends with self-aligning ball bearings — Technical specification*

EN 2099, *Aerospace series — Steel FE-PL71 — Carburized, hardened and tempered — Bars $D_e \leq 100$ mm*¹⁾

EN 2133, *Aerospace series — Cadmium plating of steels with specified tensile strength $\leq 1\,450$ MPa, copper, copper alloys and nickel alloys*

1) In preparation at the date of publication of this standard.

EN 2135, *Aerospace series — Steel FE-PL61 — Carburized, hardened and tempered — Bar $D_e \leq 40$ mm* ²⁾

EN 2424, *Aerospace series — Marking of aerospace products*

EN 9133, *Aerospace series — Quality management systems — Qualification procedure for aerospace standard parts*

ISO 1132-1, *Rolling bearings — Tolerances — Part 1: Terms and definitions*

ISO 3161, *Aerospace — UNJ threads — General requirements and limit dimensions*

ISO 3353-1, *Aerospace — Lead and runout threads — Part 1: Rolled external threads*

ISO 8075, *Aerospace — Surface treatment of hardenable stainless steel parts*

MIL-PRF-23827, *Grease, aircraft and instrument, gear and actuator screw, NATO code number G-354* ³⁾

MIL-PRF-81322, *Grease, aircraft, general purpose, wide temperature range NATO code G-395* ³⁾

3 Symbols and definitions

For the purposes of this document, the symbols and definitions given in ISO 1132-1 and the following apply.

- Δ_{ds} is the deviation of a single bore diameter;
- Δ_{dmp} is the single plane mean bore diameter deviation;
- α is the angular displacement permissible between inner and outer ring axis of a set of aligning bearing; <https://standards.iteh.ai/catalog/standards/sist/acc92b9b-25d0-4d0a-987c-5917e361052e/sist-en-4156-2014>
- C_s is the permissible static radial load;
- F_a max. is the permissible static axial load.

4 Required characteristics

4.1 Dimensions – Tolerances – Masses

Configuration : see Figure 1.

Values : see Figure 1 and Table 1: values after cadmium plating and passivating.

4.2 Surface roughness

See Figure 1, values prior to cadmium plating and passivating.

Rolling elements and raceways: $R_a = 0,2 \mu\text{m}$ (8 μin).

2) Published as ASD-STAN Prestandard at the date of publication of this standard (www.asd-stan.org).

3) Published by: Department of Defense (DoD), <http://www.defenselink.mil/>.

EN 4156:2013 (E)**4.3 Materials**

- Rod end : Steel EN 2135 or EN 2099; heat treated to obtain:
- by case hardening, hardening and tempering a surface hardness of ≥ 58 HRC on the raceway;
 - by hardening and tempering a strength $R_m \geq 830$ MPa on the whole rod end.
- Inner ring : Steel EN 2030.
- Rolling elements : Steel EN 2030.
- Seals : Polytetrafluoroethylene (PTFE) or glass fabric reinforced polytetrafluoroethylene (PTFE).
- Shields : Corrosion resisting material.
- Retaining rings : Corrosion resisting material.

4.4 Surface treatment

- Rod end : All outer surfaces with the exception of the raceway, cadmium plating and chromating as per EN 2133, 10 μm to 20 μm (400 μin to 800 μin).
- Exception: threads, coat thickness 5 μm to 10 μm (200 μin to 400 μin).
- Inner ring and rolling elements : passivated ISO 8075.

ITeH STANDARD PREVIEW
(standards.iteh.ai)

[SIST EN 4156:2014](https://standards.iteh.ai/catalog/standards/sist/acc92b9b-25d0-4d0a-987c-5917e361052e/sist-en-4156-2014)

<https://standards.iteh.ai/catalog/standards/sist/acc92b9b-25d0-4d0a-987c-5917e361052e/sist-en-4156-2014>

$\sqrt{3,2 \mu\text{m}}$ / $125 \mu\text{in}$, $\sqrt{0,8 \mu\text{m}}$ / $32 \mu\text{in}$

Dimensions in millimetres (inches)

Break sharp edges and corners and remove all burrs and slivers.

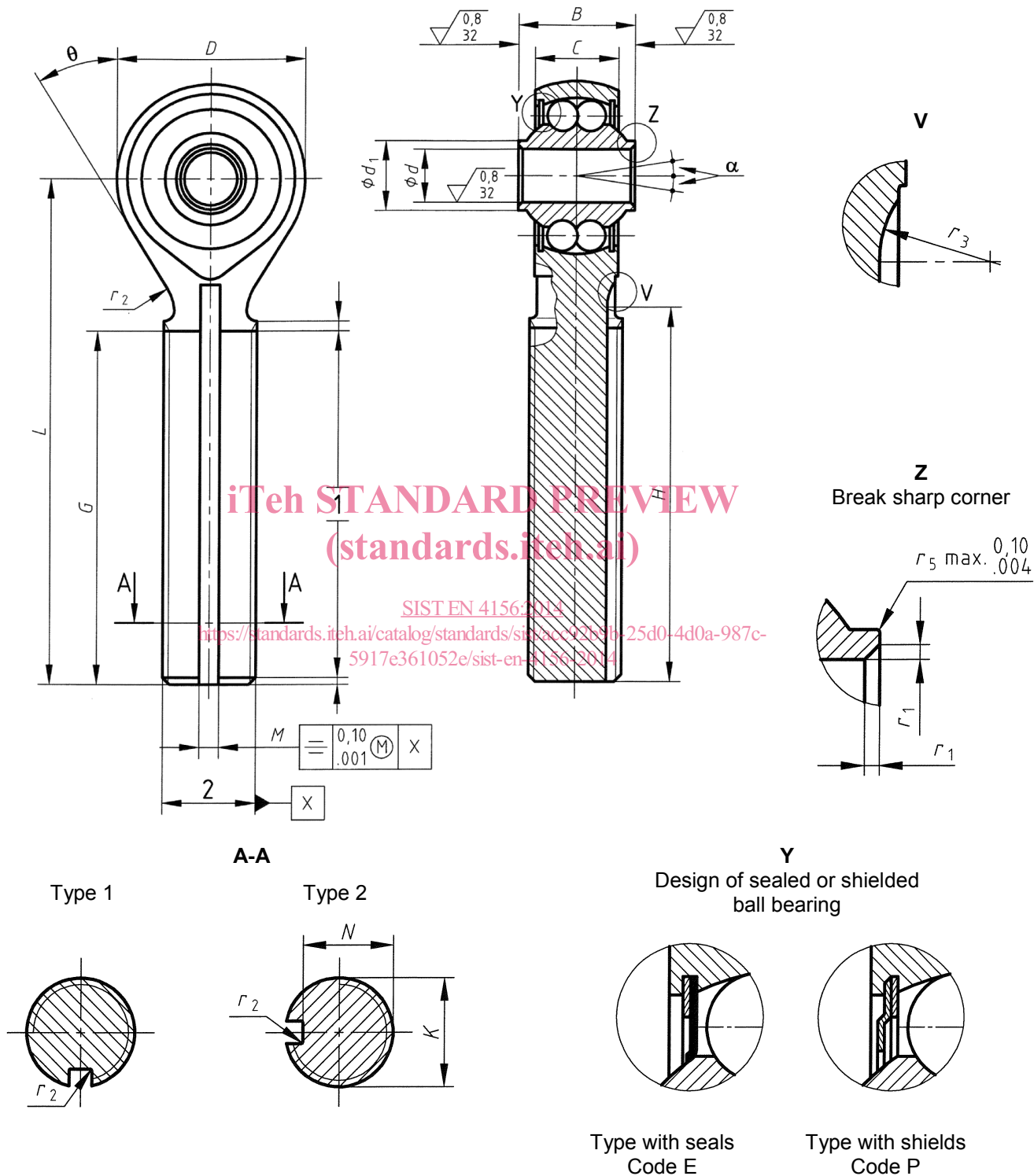

Key

- 1 conforms to ISO 3353-1
- 2 thread

NOTE The installation of seals and shields is at the manufacturer's option.

Figure 1