



SLOVENSKI STANDARD
SIST ISO 137:1995

01-december-1995

Jc`bU!`8 c`c Ub`Y`dfYa YfUj`U_Yb`!`A YfcXUg`dfc`Y_W`g`ja`a`]_fcg_cdca

Wool -- Determination of fibre diameter -- Projection microscope method

Laine -- Détermination du diamètre des fibres -- Méthode du microscope à projection

Ta slovenski standard je istoveten z: ISO 137:1975

[SIST ISO 137:1995](https://standards.iteh.ai/catalog/standards/sist/34856848-a2c8-4ce9-865c-d0a050e22d05/sist-iso-137-1995)

<https://standards.iteh.ai/catalog/standards/sist/34856848-a2c8-4ce9-865c-d0a050e22d05/sist-iso-137-1995>

ICS:

59.060.10 Naravna vlakna Natural fibres

SIST ISO 137:1995 **en**

iTeh STANDARD PREVIEW
(standards.iteh.ai)

SIST ISO 137:1995

<https://standards.iteh.ai/catalog/standards/sist/34856848-a2c8-4ce9-865c-d0a050e22d05/sist-iso-137-1995>

INTERNATIONAL STANDARD**137**

INTERNATIONAL ORGANIZATION FOR STANDARDIZATION • МЕЖДУНАРОДНАЯ ОРГАНИЗАЦИЯ ПО СТАНДАРТИЗАЦИИ • ORGANISATION INTERNATIONALE DE NORMALISATION

Wool — Determination of fibre diameter — Projection microscope method

Laine — Détermination du diamètre des fibres — Méthode du microscope à projection

First edition — 1975-02-01

iTeh STANDARD PREVIEW
(standards.iteh.ai)

[SIST ISO 137:1995](#)

<https://standards.iteh.ai/catalog/standards/sist/34856848-a2c8-4ce9-865c-d0a050e22d05/sist-iso-137-1995>

UDC 677.31 : 677.017.224.2

Ref. No. ISO 137-1975 (E)

Descriptors : natural fibres, animal fibres, wool fibres, measurement, dimensions, diameters, microscopic analysis.

Price based on 7 pages

FOREWORD

ISO (the International Organization for Standardization) is a worldwide federation of national standards institutes (ISO Member Bodies). The work of developing International Standards is carried out through ISO Technical Committees. Every Member Body interested in a subject for which a Technical Committee has been set up has the right to be represented on that Committee. International organizations, governmental and non-governmental, in liaison with ISO, also take part in the work.

Draft International Standards adopted by the Technical Committees are circulated to the Member Bodies for approval before their acceptance as International Standards by the ISO Council.

International Standard ISO 137 was drawn up by Technical Committee ISO/TC 38, *Textiles*, and circulated to the Member Bodies in September 1973.

It has been approved by the Member Bodies of the following countries :

Brazil	Hungary	Sweden
Bulgaria	India	Switzerland
Canada	Ireland	Thailand
Chile	Italy	Turkey
Czechoslovakia	Japan	United Kingdom
Denmark	New Zealand	U.S.A.
Egypt, Arab Rep. of	Poland	U.S.S.R.
Finland	Romania	Yugoslavia
France	South Africa, Rep. of	
Germany	Spain	

The Member Body of the following country expressed disapproval of the document on technical grounds :

Belgium

This International Standard cancels and replaces ISO Recommendation R 137-1960, of which it constitutes a technical revision.

Wool – Determination of fibre diameter – Projection microscope method

0 INTRODUCTION

The method of measuring fibre diameter by the projection microscope is used throughout the world in various forms and is thus appropriate for international standardization.

1 SCOPE

This International Standard specifies the procedure and the conditions of measurement for the determination of wool fibre diameter by means of the projection microscope.

2 FIELD OF APPLICATION

The method is suitable for wool fibres in any form and also for other fibres of reasonably circular cross-section.¹⁾

3 REFERENCES

ISO 139, *Textiles – Standard atmospheres for conditioning and testing*.

ISO/R 1130, *Methods of fibre sampling for testing*.

4 PRINCIPLE

Projection on a screen of the magnified images of the profiles of wool fibre pieces, and measurement of their width by means of a graduated scale.

The operating technique assures a random sampling of the fibres to be measured.

5 APPARATUS

5.1 Projection microscope comprising a light source, a light condenser, a stage which supports the slide carrying the fibres, an objective, an ocular and a circular screen.

5.1.1 The stage is movable in two directions at right angles by means of a sliding mechanism capable of successive displacements in 0,5 mm steps.

5.1.2 The objective and ocular are capable of providing 500 X magnification.

5.1.3 The circular screen with graduated scale is able to rotate about its centre in its plane.

If this screen is not transparent, it shall carry a transparent scale, 5 cm wide, graduated in millimetres along its underside, movable diametrically across the screen between guides.

If the screen is transparent, the transparent scale, graduated in millimetres and used to measure the width of the projected image, must be placed along one of the diameters. The graduated scale must be able to rotate about the centre of the circular screen and in its plane.

In the centre of the circular screen there is a circle whose diameter is equal to a quarter of the optical distance between the ocular and the centre of the screen. All measurements shall be made inside this circle.

5.1.4 The projection microscope shall be calibrated periodically by means of a micrometer scale (certified accurate), divided in hundredths of a millimetre and placed on the stage. One division of the micrometer (i.e. 0,01 mm), projected on the screen, shall cover exactly 5 mm of the graduated scale. The magnification is then equal to 500 X.

1) In the case of dyed, bleached or finished fibres, it should be noted that the diameter may be different from that of fibres not subjected to such treatments. The estimates of fibre diameter obtained at the various stages of processing one lot of wool will not necessarily be the same.

ISO 137-1975 (E)

5.2 Microtome for cutting the fibres to lengths of 0,8 mm, 0,6 mm or 0,4 mm.

A suitable microtome, shown in figure 1, consists of the following elements :

- Steel plate** with a slot.
- Steel tongue**, fixed to guides which slide along the plate, and adjustable in such a manner that it enters the slot to a pre-determined distance.
- Steel blade pushers**, equal in thickness to the width of the microtome slot, each with a stop plate situated at a fixed distance from one of its ends.

A set of three pushers shall be available, the stop plates of which are situated at distances of 0,8 mm, 0,6 mm and 0,4 mm from one of their respective ends.

5.3 Mounting medium having the following properties :

- a refractive index between 1,43 and 1,53, at 20 °C;
- a suitable viscosity;
- zero water absorption;
- no effect on the diameter of the fibre.

Cedar wood oil and liquid paraffin are examples of suitable media.

5.4 Cover-glass, 50 mm X 35 mm No. 1 (i.e. 0,13 mm to 0,17 mm thickness).

6 SAMPLING AND PREPARATION OF THE SPECIMENS

6.1 Raw wool

6.1.1 Proceed in the following manner, which conforms with sub-clause 6.2 of ISO/R 1130.

Divide the mass of the samples into roughly 40 zones and take a handful of fibres from each zone. Divide each handful into two (taking care to avoid breaking the fibres) and reject one-half, choosing the half to be rejected at random. If the fibres are parallel, make the division into two longitudinally, i.e. in a direction which avoids selection of fibres by their ends. Divide the retained half into two and again reject half at random. Continue in this way until each portion contains about 25 fibres. The reduced sample thus contains about 1 000 fibres.

6.1.2 Submit the reduced sample to a washing treatment consisting of two extractions in petroleum ether. Dry the sample and condition it in the standard atmosphere for conditioning defined in ISO 139.

6.1.3 Then, by means of scissors or a similar instrument, cut all the fibres in the reduced sample into pieces 0,5 to 1 mm long. Divide the pieces into 16 zones, take from each a small quantity and place it in a few drops of mounting medium (5.3) on a glass slide about 75 mm X 40 mm. Then stir the pieces well into the mounting medium so as to obtain uniform distribution. Lower the cover-glass (5.4) on to the slide, placing one edge in contact with the slide, and gently lowering the opposite edge on to the slide.

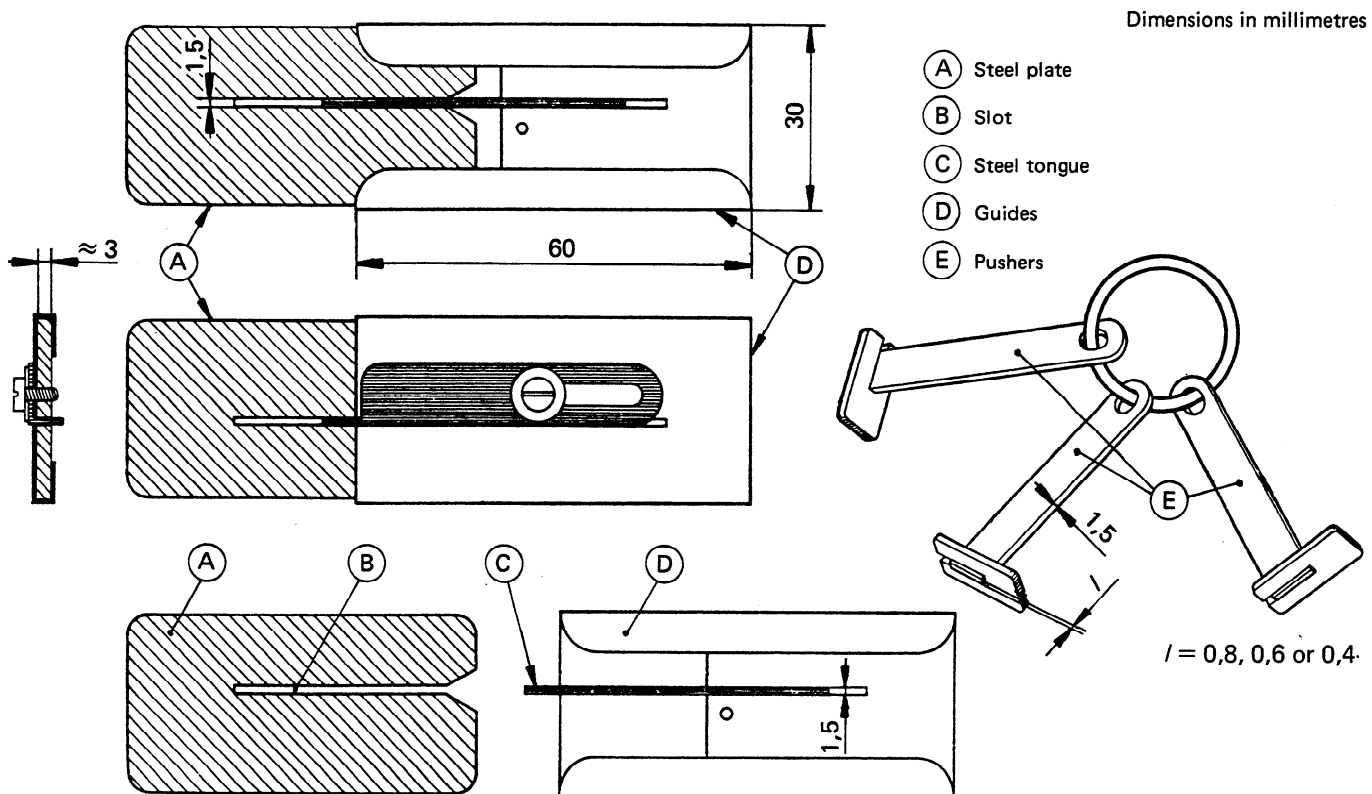

FIGURE 1 — Details of microtome

6.2 Slivers, rovings and yarns

6.2.1 From the sample, which shall be as representative as possible of the bulk, take a sufficient quantity of material to fill the slot of the microtome to a sufficient depth. Long fibres are generally thick fibres, and consequently any manipulation resulting in selection of long fibres will give too great an average diameter.

6.2.2 Condition the specimen thus obtained in the standard atmosphere for conditioning defined in ISO 139.

6.2.3 Place the specimen in the slot of the microtome. Next, insert the steel tongue and push it hard so as to compress the sliver. With a razor-blade cut off the projecting fibres flush with both faces of the steel plate. A bundle of fibres will remain in the microtome slot. By inserting the pusher from one side, the bundle of fibres can be forced out at the other side to a length of 0,8 mm, 0,6 mm or 0,4 mm, according to the pusher used (see table 1). Cut off the emerging fibres flush with the face of the steel plate with a razor-blade.

TABLE 1 – Choice of pushers

Fibres		Pushers
Form	Average diameter	Distance between stop plate and end of pusher mm
	μm	
Slivers and rovings	> 27	0,8
	< 27	0,4
Yarns	> 27	0,6
	< 27	0,4

6.2.4 Place all the fibres cut with the microtome on a slide and mix with a few drops of mounting medium (5.3) until the fibres are completely and evenly distributed.

Remove sufficient of the mixture before covering the slide to ensure that no oil is squeezed from under the cover-glass when it is placed on the slide. This will ensure no preferential removal of thin fibres.

7 PROCEDURE

7.1 Examination of the specimen

Place the slide on the microscope stage, the cover-glass towards the objective.

After the fibres have settled, examine the specimen in different fields. The distance between the centres of the fields should be theoretically greater than the length of the cut fibres, otherwise the same cut fibre could be measured

twice. However, if the centres are only 0,5 mm apart, the probability of measuring the same cut fibre twice is slight enough to be overlooked. Thus, the sliding mechanism should be provided with means for traversing by 0,5 mm steps. A system of fields whose centres are 0,5 mm apart will be adequate.

Begin the examination by focusing first the corner A of the cover-glass (see figure 2). Move the slide 0,5 mm in the transverse direction to B, then move it 0,5 mm in the lateral direction. These two traverses will bring the first field onto the screen. Measure the diameter of each fibre within the circle of the field, in accordance with the established rules as follows :

Exclude from measurement

- fibres which have more than half their width outside the circle;
- fibres which end within the width of the transparent scale;
- fibres which cross another fibre at the point of measurement.

The stage shall remain stationary during the measurement in a given field. It may happen that in a field there will be no fibres at all, or only one or two.

When the fibres have been measured in the first field, move the slide 0,5 mm in the lateral direction, thus bringing the second field onto the screen. Continue in this way along the whole length of the cover-glass. Having reached C on the right-hand edge of the cover-glass, move the slide 0,5 mm in the transverse direction to D and continue examination laterally by 0,5 mm steps, and so on. Traverse the whole cover-glass in this way, following the path A, B, C, D, E, F, G . . .

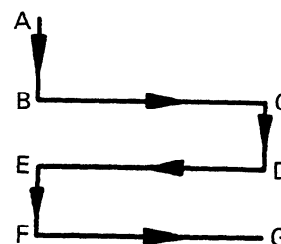

FIGURE 2 – Examination of the specimen

By following this procedure, the operator has no free choice of the fibres to be measured.

7.2 Focusing

When the lens is too near the slide, a fibre edge shows a white border. When the lens is too far from the slide, a fibre edge shows a black border.

When in focus, the fibre edge shows as a fine line without a border. However, it is not usual for both edges of a fibre image to be in focus together, since wool fibres are in general non-circular in cross-section.

ISO 137-1975 (E)

When measuring a fibre whose edges are not in focus together, adjust the focusing so that one edge is in focus and the other shows a white line. Then measure the width from the edge that is in focus to the inside of the white line. Figure 3 shows a fibre correctly and incorrectly focused.

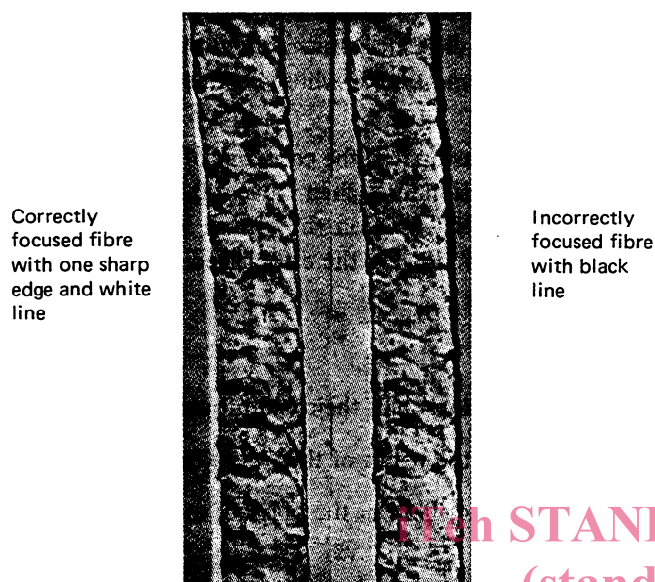

Correctly focused fibre with one sharp edge and white line

Incorrectly focused fibre with black line

However, it sometimes happens that the diameter of a fibre corresponds exactly to a whole number of millimetres N ; this fibre belongs at the same time to the $N - 0,5$ group (recorded as $N - 1$) and to the $N + 0,5$ group (recorded as N). If such a fibre is recorded under the $N - 1$ group, it is called "underestimated"; if it is entered in the N group, it is called "over-estimated".

When such fibres, measuring an exact number of millimetres, occur, underestimate and over-estimate them alternately.

8 CALCULATION AND EXPRESSION OF RESULTS

Calculate the mean arithmetic measurement in millimetres; obtain the average diameter of fibres in micrometres (μm) at a magnification of $500\times$, by multiplying the mean arithmetic measurement by 2.

The percentage coefficient of variation V , is given by the following formula :

$$V \% = \frac{100 s}{\bar{x}}$$

where

s is the standard deviation;

\bar{x} is the average value of the diameter.

Express the accuracy of the result by the confidence limits (see annexes A and B).

FIGURE 3 – Correctly and incorrectly focused fibre

7.3 Recording of measurements

For each fibre, bring one of the principal divisions of the graduated scale tangentially to the focused edge of the fibre. Read the diameter up to the other side of the fibre, in accordance with the instructions in the previous paragraph. The results of the measurements may be entered on a form, for example a working sheet (see annex A).

Generally, the unfocused edge of the fibre falls between two divisions of the scale. Enter the fibre under the lower whole number of millimetres N . In the subsequent calculation, all fibres recorded under N will be regarded as having a diameter equal to $N + 0,5$ mm.

9 TEST REPORT

The test report shall include the following information :

- that the tests were conducted in accordance with this International Standard;
- the type, form and condition of the fibres tested;
- the average diameter of the fibres in micrometres;
- the number of determinations of diameter made;
- the percentage coefficient of variation of the results and the confidence limits.

ANNEX A

EXAMPLE OF CALCULATION

Diameter mm		Number of measurements <i>f</i>	Deviation from assumed arithmetic mean <i>e</i>	<i>fe</i>	<i>(fe)e</i>
1					
2					
3					
4	•	1	- 6	- 6	36
5	••	2	- 5	- 10	50
6	••••• •••••	9	- 4	- 36	144
7	••••• ••••• ••••• ••••• ••••• ••••• •	26	- 3	- 78	234
8	••••• ••••• ••••• ••••• ••••• •••••	48	- 2	- 96	192
9	••••• ••••• ••••• ••••• •••••	49	- 1	- 49	49
10	••••• ••••• ••••• ••••• ••••• ••••• •••••	63	0	0	0
11	••••• ••••• ••••• ••••• ••••• ••••• •••••	43	+ 1	+ 43	43
12	••••• ••••• ••••• ••••• ••••• ••••• •••••	22	+ 2	+ 44	88
13	••••• ••••• ••••• ••••• ••••• ••••• •	26	+ 3	+ 78	234
14	••••• ••••• ••••• ••••• •••••	18	+ 4	+ 72	288
15	•••••	4	+ 5	+ 20	100
16	•••••	4	+ 6	+ 24	144
17	•••••	5	+ 7	+ 35	245
18		0	+ 8	0	0
19	••	2	+ 9	+ 18	162
20		0	+ 10	0	0
21	•	1	+ 11	+ 11	121
22					
23					
24					
25					
	TOTALS	323		- 275 + 345 = + 70	2 130