**Road vehicles — Multi-core connecting
cables —**

Part 3:

**Construction, dimensions and marking of
unscreened sheathed low-voltage cables**

iTeh STANDARD PREVIEW
*Véhicules routiers — Câbles de raccordement multiconducteurs —
Partie 3: Construction, dimensions et marquage des câbles basse
tension gainés non blindés*

[ISO 4141-3:2006](https://standards.iso.org/standards/catalog/standards/sist/10d514c9-2768-41cc-9447-098b5e4716a9/iso-4141-3-2006)

<https://standards.iso.org/standards/catalog/standards/sist/10d514c9-2768-41cc-9447-098b5e4716a9/iso-4141-3-2006>



Reference number
ISO 4141-3:2006(E)

PDF disclaimer

This PDF file may contain embedded typefaces. In accordance with Adobe's licensing policy, this file may be printed or viewed but shall not be edited unless the typefaces which are embedded are licensed to and installed on the computer performing the editing. In downloading this file, parties accept therein the responsibility of not infringing Adobe's licensing policy. The ISO Central Secretariat accepts no liability in this area.

Adobe is a trademark of Adobe Systems Incorporated.

Details of the software products used to create this PDF file can be found in the General Info relative to the file; the PDF-creation parameters were optimized for printing. Every care has been taken to ensure that the file is suitable for use by ISO member bodies. In the unlikely event that a problem relating to it is found, please inform the Central Secretariat at the address given below.

iTeh STANDARD PREVIEW
(standards.iteh.ai)

ISO 4141-3:2006

<https://standards.iteh.ai/catalog/standards/sist/10d514c9-2768-41cc-9447-098b5e4716a9/iso-4141-3-2006>

© ISO 2006

All rights reserved. Unless otherwise specified, no part of this publication may be reproduced or utilized in any form or by any means, electronic or mechanical, including photocopying and microfilm, without permission in writing from either ISO at the address below or ISO's member body in the country of the requester.

ISO copyright office
Case postale 56 • CH-1211 Geneva 20
Tel. + 41 22 749 01 11
Fax + 41 22 749 09 47
E-mail copyright@iso.org
Web www.iso.org

Published in Switzerland

Foreword

ISO (the International Organization for Standardization) is a worldwide federation of national standards bodies (ISO member bodies). The work of preparing International Standards is normally carried out through ISO technical committees. Each member body interested in a subject for which a technical committee has been established has the right to be represented on that committee. International organizations, governmental and non-governmental, in liaison with ISO, also take part in the work. ISO collaborates closely with the International Electrotechnical Commission (IEC) on all matters of electrotechnical standardization.

International Standards are drafted in accordance with the rules given in the ISO/IEC Directives, Part 2.

The main task of technical committees is to prepare International Standards. Draft International Standards adopted by the technical committees are circulated to the member bodies for voting. Publication as an International Standard requires approval by at least 75 % of the member bodies casting a vote.

Attention is drawn to the possibility that some of the elements of this document may be the subject of patent rights. ISO shall not be held responsible for identifying any or all such patent rights.

ISO 4141-3 was prepared by Technical Committee ISO/TC 22, *Road vehicles*, Subcommittee SC 3, *Electrical and electronic equipment*.

This second edition cancels and replaces the first edition (ISO 4141-3:1998), which has been technically revised. It also incorporates the Technical Corrigendum ISO 4141-3:1998/Cor.1:1999.

ISO 4141 consists of the following parts, under the general title *Road vehicles — Multi-core connecting cables*:

- *Part 1: Test methods and requirements for basic performance sheathed cables*
- *Part 2: Test methods and requirements for high performance sheathed cables*
- *Part 3: Construction, dimensions and marking of unscreened sheathed low-voltage cables*
- *Part 4: Articulation test method and requirements for coiled cable assemblies*

The following part is under preparation:

- *Part 4: Test methods and requirements for coiled cable assemblies* [Revision of ISO 4141-4:2001]

iTeh STANDARD PREVIEW
(standards.iteh.ai)

ISO 4141-3:2006

<https://standards.iteh.ai/catalog/standards/sist/10d514c9-2768-41cc-9447-098b5e4716a9/iso-4141-3-2006>

Road vehicles — Multi-core connecting cables —

Part 3:

Construction, dimensions and marking of unscreened sheathed low-voltage cables

1 Scope

This part of ISO 4141 specifies the construction, dimensions and marking of unscreened sheathed low-voltage multi-core cables for the connection of towing and towed vehicles, suitable for the temperature range – 40 °C to + 85 °C.

2 Normative references

The following referenced documents are indispensable for the application of this document. For dated references, only the edition cited applies. For undated references, the latest edition of the referenced document (including any amendments) applies.

ISO 1185, *Road vehicles — Connectors for the electrical connection of towing and towed vehicles — 7-pole connector type 24 N (normal) for vehicles with 24 V nominal supply voltage*

ISO 1724, *Road vehicles — Connectors for the electrical connection of towing and towed vehicles — 7-pole connector type 12 N (normal) for vehicles with 12 V nominal supply voltage*

ISO 3731, *Road vehicles — Connectors for the electrical connection of towing and towed vehicles — 7-pole connector type 24 S (supplementary) for vehicles with 24 V nominal supply voltage*

ISO 3732, *Road vehicles — Connectors for the electrical connection of towing and towed vehicles — 7-pole connector type 12 S (supplementary) for vehicles with 12 V nominal supply voltage*

ISO 4141-1, *Road vehicles — Multi-core connecting cables — Part 1: Test methods and requirements for basic performance sheathed cables*

ISO 4141-2, *Road vehicles — Multi-core connecting cables — Part 2: Test methods and requirements for high performance sheathed cables*

ISO 7638-1, *Road vehicles — Connectors for the electrical connection of towing and towed vehicles — Part 1: Connectors for braking systems and running gear of vehicles with 24 V nominal supply voltage*

ISO 7638-2, *Road vehicles — Connectors for the electrical connection of towing and towed vehicles — Part 2: Connectors for braking systems and running gear of vehicles with 12 V nominal supply voltage*

ISO 11446, *Road vehicles — Connectors for the electrical connection of towing and towed vehicles — 13-pole connectors for vehicles with 12 V nominal supply voltage*

ISO 12098, *Road vehicles — Connectors for the electrical connection of towing and towed vehicles — 15-pole connector for vehicles with 24 V nominal supply voltage*

3 General Requirements

Multi-core sheathed connecting cables for basic performance according to this International Standard shall comply with the requirements of ISO 4141, Part 1.

Multi-core sheathed connecting cables for high performance according to this International Standard shall comply with the requirements of ISO 4141, Part 2.

4 Construction and dimensions

4.1 Single cores

4.1.1 General

During construction of the cable, the positions of the single cores within the cable construction shall be laid up, as far as possible, in accordance with the contact positions of the connector as specified in ISO 1185, ISO 1724, ISO 3731, ISO 3732, ISO 7638-1, ISO 7638-2, ISO 11446, or ISO 12098 as applicable.

NOTE Annex A gives a synopsis of the nominal cross-sections of single cores in multi-core cables specified in the International Standards cited above.

4.1.2 Data cores lay length

The lay length of the data cores shall be max. 50 mm.

4.1.3 Additional elements

Fillers may be used to complete the cable construction. Non-metallic tapes or wrappings under the sheath or an inner sheath may be applied.

4.2 Outer sheath dimensions

4.2.1 Thickness

The minimum thickness of the sheath, measured in accordance with ISO 4141-1, shall be 1 mm for uncoiled cables, and 1,2 mm for coiled cables.

4.2.2 Outside diameter

The outside diameter of the multi-core cable, measured in accordance with ISO 4141-1, shall be as specified in Table 1.

The cable ovality, measured in accordance with ISO 4141-1, shall not exceed 10 %.

Table 1 — Outside diameter of multi-core cables

Dimensions in millimetres

Outside diameter	Multi-core cable for use with connectors as in							
	ISO 1185	ISO 1724	ISO 3731	ISO 3732	ISO 7638		ISO 11446	ISO 12098
					5 poles	7 poles		
max.	13,5	13,5	13,5	13,5	13,5	15,5	15,0	17,0
min.	8,0	8,0	8,0	8,0	8,0	11,0	10,0	14,0

4.3 Coil dimensions

Dimensions of the coiled connecting cables shall be as detailed in Table 2 and Figure 1.

Table 2 — Overall dimensions of coiled multi-core cables

Dimensions in millimetres

Type of coiled connecting cable	Block length L_B max.	Working length L_A max.	Max. admitted extension length L_{Amax}
1	500	1 750	3 000
2	550	2 250	4 000
3	575	2 500	4 500

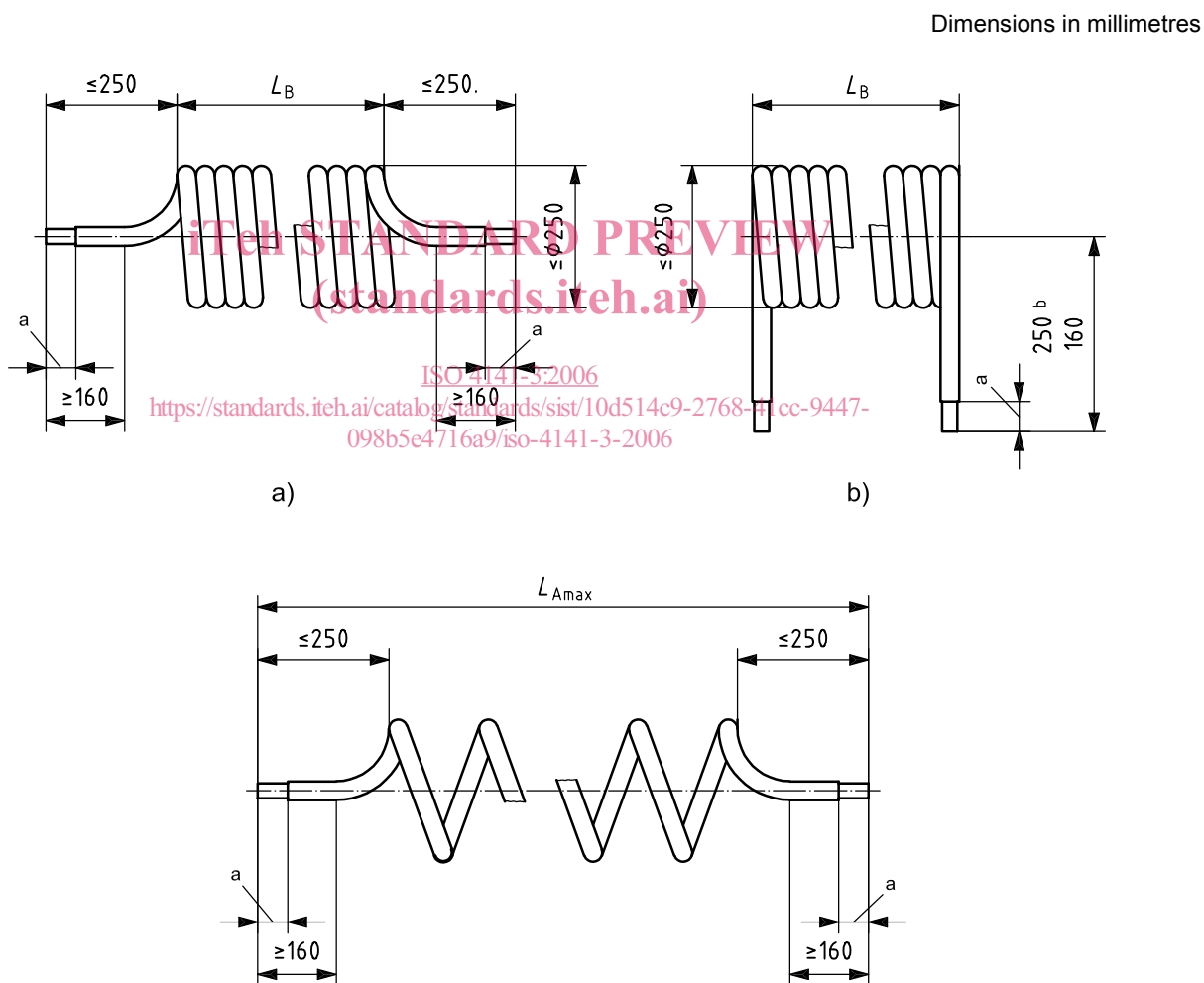

Key

- a As agreed between manufacturer and user.
- b Minimum straight tail length required.

Figure 1 — Overall dimensions of coiled connecting cables

5 Marking

5.1 Cores

Cores shall be identified by either of the following:

- a) by the insulation colour as specified in Table 3; or
- b) by numerals as specified in Figure 2 and Table 3, printed in a colour contrasting with that of the core insulation.

Alternative methods may be used by agreement between manufacturer and user.

Table 3 — Colour and marking of cores

Single core insulation colour	Single cores allocated to and marked with contact number according to the connector International Standard						
	ISO 1185	ISO 1724	ISO 3731	ISO 3732	ISO 7638-1 and 7638-2	ISO 11446	ISO 12098
Yellow	3	1	3	1	3	1	1
Blue	7	2	7	2	—	2	3
White	1	3	1	3	5	3	4
Green	5	4	5	4	—	4	2
Brown	6	5	6	5	4	5	6
Red	4	6	4	6	1	6	7
Black	2	7	2	7	2	7	5
Pink	—	—	—	—	—	8	8
Orange	—	—	—	—	—	9	9
Gray	—	—	—	—	—	10	10
White/Green	—	—	—	—	6	—	14
White/Brown	—	—	—	—	7	—	15
White/Black	—	—	—	—	—	11	11
White/Blue	—	—	—	—	—	12	12
White/Red	—	—	—	—	—	13	13

NOTE For functional allocation see the connector standards indicated.

5.2 Sheath

Multi-core cable sheaths shall be marked, as indicated in Figure 3, with the manufacturer's identification and the following application characters:

- 7 core cables for 12N connectors: 12N;
- 7 core cables for 12S connectors: 12S;
- 7 core cables for 24N connectors: 24N;
- 7 core cables for 24S connectors: 24S;

- 5 core cables for antilock braking systems: ABS;
- 7 core cables for electronically controlled braking systems: EBS;
- 8 to 12 core cable for 13 pole connectors: 12-8...12-12;
- 8 to 15 core cable for 15 pole connectors: 24-8...24-15.

The marking of the sheath shown in Figure 3 shall point to that end of the cable where the cores should be arranged to match with the contacts on the plug as specified in 4.1.

For cables having a plug at each end (for example between the tractor and semi-trailer), it is possible to omit this marking.

Dimensions in millimetres

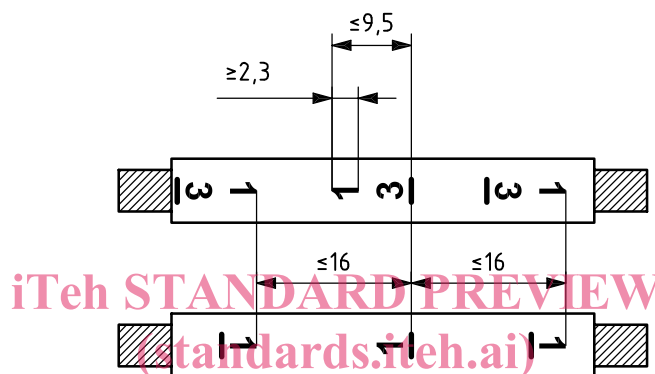

ISO 4141-3:2006

<https://standards.itih.ai/standards/iso-4141-3-2006> **Figure 2 — Marking of cores** <https://standards.itih.ai/standards/iso-4141-3-2006>

Dimensions in millimetres

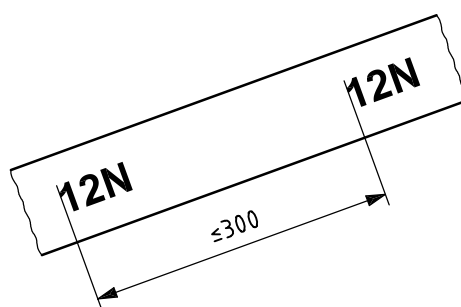

Figure 3 — Marking of sheath