



Designation: D 2396 – 94 (Reapproved 1999)^{e1}

Standard Test Methods for Powder-Mix Time of Poly(Vinyl Chloride) (PVC) Resins Using a Torque Rheometer¹

This standard is issued under the fixed designation D 2396; the number immediately following the designation indicates the year of original adoption or, in the case of revision, the year of last revision. A number in parentheses indicates the year of last reapproval. A superscript epsilon (ϵ) indicates an editorial change since the last revision or reapproval.

^{e1} NOTE—Inch-pound units were deleted editorially in April 2000.

1. Scope

1.1 These test methods cover the determination of the powder-mix time of a general-purpose poly(vinyl chloride) (PVC) resin.

1.2 The values stated in SI units are to be regarded as standard.

1.3 *This standard does not purport to address all of the safety concerns, if any, associated with its use. It is the responsibility of the user of this standard to establish appropriate safety and health practices and determine the applicability of regulatory limitations prior to use.*

NOTE 1—There is no ISO standard covering the primary subject of these ASTM test methods.

2. Referenced Documents

2.1 *ASTM Standards:*

D 883 Terminology Relating to Plastics²

D 1600 Terminology for Abbreviated Terms Relating to Plastics²

3. Terminology

3.1 *General:*

3.1.1 Definitions are in accordance with Terminology D 883 and abbreviations are in accordance with Terminology D 1600 unless otherwise indicated.

4. Summary of Test Methods

4.1 A sample of resin is heated and mixed in a bowl to the test temperature. A measured amount of plasticizer is added to the resin through a dispersing funnel. When the plasticizer is added to the resin, the mix becomes wet and an increase in motor torque is needed to maintain the same rotor speed. As the mixing continues in the heated bowl, the plasticizer is absorbed

into the resin and the resin granules become dry and free-flowing. When the mix reaches the dry and free-flowing state, its resistance to stirring decreases and the motor torque needed to maintain the same rotor speed decreases. By recording the changes in motor torque with time, it is possible to measure the time required for a resin to absorb a plasticizer.

4.2 These test methods describe the use of two different mixing heads that can be mounted on a torque rheometer to perform this test. Test results obtained with these mixing heads are compared in Section 14.

4.2.1 A sigma mixing head is used in Test Method A.

4.2.2 A planetary mixing head is used in Test Method B.

5. Significance and Use

5.1 The ability of PVC granules to accept a plasticizer and become a dry free-flowing powder is related to the internal pore structure of the resin, resin temperature, plasticizer temperature, and the plasticizer used. By choosing an applicable plasticizer and maintaining a uniform temperature for the resin and plasticizer, it is possible to classify resins by how rapidly they absorb plasticizer. Resin suitability for a specific intensive mixing operation can be ascertained using these test methods.

6. Interferences

6.1 *Resin*—Each resin has a specific response in accepting a plasticizer. Differences in powder-mix time between resins can be observed in the graph in the annex.

6.2 *Plasticizer*—Plasticizer viscosity directly affects powder-mix time. Table 1 shows that an increase in diisodecyl phthalate viscosity results in an increase in powder-mix time. The data in Table 1 was generated in a single laboratory using Test Method A.

6.3 *Temperature*—The temperature at which the test is performed will affect the powder-mix time. A lower test temperature will have a longer powder-mix time.

NOTE 2—It is also important to control the temperature of the plasticizer added to the resin. The powder-mix time can vary by as much as 3

¹ These test methods are under the jurisdiction of ASTM Committee D-20 on Plastics and are the direct responsibility of Subcommittee D20.15 on Thermoplastic Materials.

Current edition approved June 15, 1994. Published August 1994. Originally published as D 2396 – 69. Last previous edition D 2396 – 88.

² *Annual Book of ASTM Standards*, Vol 08.01.

TABLE 1 Powder-Mix Time of ASTM No. 1 Resin

DIDP Viscosity, cP (millipascals-s) ^A	Bowl Temperature, °C ^B	Mean Powder-Mix Time, s	Standard Deviation	Number of Samples
111	85	435	...	2
128	85	461	6.9	5
147	85	479	...	2

^AViscosity was measured using a Brookfield RVF Viscometer, No. 1 spindle, 20 r/min, at 23°C.

^BThe bowl temperature was measured at the thermocouple well.

s for each degree Fahrenheit difference in plasticizer temperature, as seen in the graph in the annex.

6.4 *Equipment*—Differences between equipment can result in differences in powder-mix times. To equate equipment, it is suggested that a specific powder-mix time be chosen and that the bowl temperature be adjusted to obtain the same time for all equipment. Table 2 shows the results from three laboratories using this technique to equate to a powder-mix time for ASTM No. 1 resin using Test Method A to the value set by Laboratory 1.

6.5 *Rotor Speed*—Observed with the planetary mixing head (see Test Method B) was a decrease in dry time when the rotor speed had been increased: 60 r/min @ 82°C using DIDP = dry time of 868 s; and 100 r/min @ 82°C using DIDP = dry time of 628 s.

7. Apparatus

7.1 *Torque Rheometer*.³

7.2 *Sigma Mixer* 650-mL,⁴ or equivalent, and the dispersion trough shown in Fig. 1 for plasticizer distribution. (For Test Method A.)

7.3 *Planetary Mixer*,⁵ and the dispersion funnel shown in Fig. 2 for plasticizer distribution. (For Test Method B.)

7.4 *Balance*, 0.1-g sensitivity.

7.5 *Container*, 0.95 L size. [https://standards.sist/23e1e007-c783-4981-82600e26aeb/astm-d2396-94\(1999\)1999e1](https://standards.sist/23e1e007-c783-4981-82600e26aeb/astm-d2396-94(1999)1999e1)

7.6 *Beaker*, 400-mL.

7.7 *Funnel*, for use with planetary mixer (see Test Method B).

7.8 *Ruler*, with metric scale.

7.9 *Paint Brush*, 25.4 mm width.

7.10 *Thermometer*, range of 40 to 100°C with 0.2°C divisions.

³The C. W. Brabender PL 2000 Computerized Plasticorder or Electronic Plasticorder, a registered trademark of C. W. Brabender Instruments, Inc., 50 E. Wesley Street, South Hackensack, NJ 07606, or System 903, a registered trademark of Haake Buchler Instruments, Inc., 244 Saddle River Road, Saddle Brook, NJ 07662, or equivalents, have been found suitable for this purpose.

⁴Suitable equipment may be obtained from C. W. Brabender Instruments, Inc., 50 E. Wesley St., South Hackensack, NJ 07606, or Haake Buchler Instruments, Inc., 244 Saddle River Rd, Saddle Brook, NJ 07662.

⁵C. W. Brabender Model 01-10-000, or equivalent, has been found suitable for this purpose.

TABLE 2 Interlaboratory Testing of ASTM No. 1 Resin

Laboratory	Powder-Mix Time, s	Bowl Temperature, °C ^A
1	454	82.0
2	454	85.0
3	450	85.5

^AThe bowl temperature was measured at the thermocouple well.

7.11 *Spatula*.

7.12 *Viscometer*, Brookfield RVF, or equivalent.

8. Materials

8.1 *Poly(Vinyl Chloride) (PVC) Resin*.

8.2 *Diisodecyl Phthalate Plasticizer*.

8.3 *Clay*.⁶

9. Safety Precautions

9.1 Take care not to exceed the manufacturer’s recommended damping limit on the sigma mixer because of the danger of bending the blades.

9.2 Stop the mixer before cleaning the bowl and blades.

10. Preparation of Torque Rheometer

10.1 *Electronic Plasti-Corder³ Torque Rheometer*:

10.1.1 Adjust the torque rheometer so that the strip chart torque range reads 200 m-g at full scale.

10.1.2 Set chart speed to 10 mm/min.

10.1.3 Place pen on chart.

10.1.4 Connect the stock temperature measuring thermocouple to the recorder and start the recorder.

10.2 *PL-2000³ Computerized Torque Rheometer*—Program the PL-2000 Plasti-Corder³ for the test conditions of:

Order:	(Run information)
Operator:	(Name)
Date:	(Current date)
PL-Type:	2000
Mixer Type:	Planetary
Sample:	PVC (source)
Plasticizer:	DIDP (source)
Mixer Temperature:	88°C
Speed:	100 r/min
Meas. Range:	500 mg
Zero Suppr:	0 %
Damping:	1 s
Test Time:	20 min
Sample Weight:	400.00 g
Plasticizer Weight:	200.00 g

NOTE 3—When using equipment other than C. W. Brabender, refer to the manufacturer’s suggested settings for their equipment.

11. Procedures

11.1 *Test Method A (Sigma Mixer)*.⁴

11.1.1 Attach the 650-mL oil (or electric) Sigma Mixer⁴ to the torque rheometer.

11.1.2 Adjust the mixer-jacket temperature to 88 ± 1°C as measured at the thermocouple well.

11.1.3 Set the mixer speed to 60 ± 1 r/min.

11.1.4 Weigh the resin and clay of the following formulation into the quart container and mix thoroughly with a spatula:

Resin	225 ± 0.1 g
Clay	40 ± 0.1 g
DIDP Plasticizer	124 ± 0.1 g

11.1.5 Wet the dispersion trough and the 400-mL beaker with plasticizer and drain both for 1 min. Tare the prewetted beaker and weigh 124 g of DIDP.

⁶Burgess No. 30, or equivalent, available from Burgess Pigment Co., Box 4146, Macon, GA 31208, has been found suitable for this purpose.

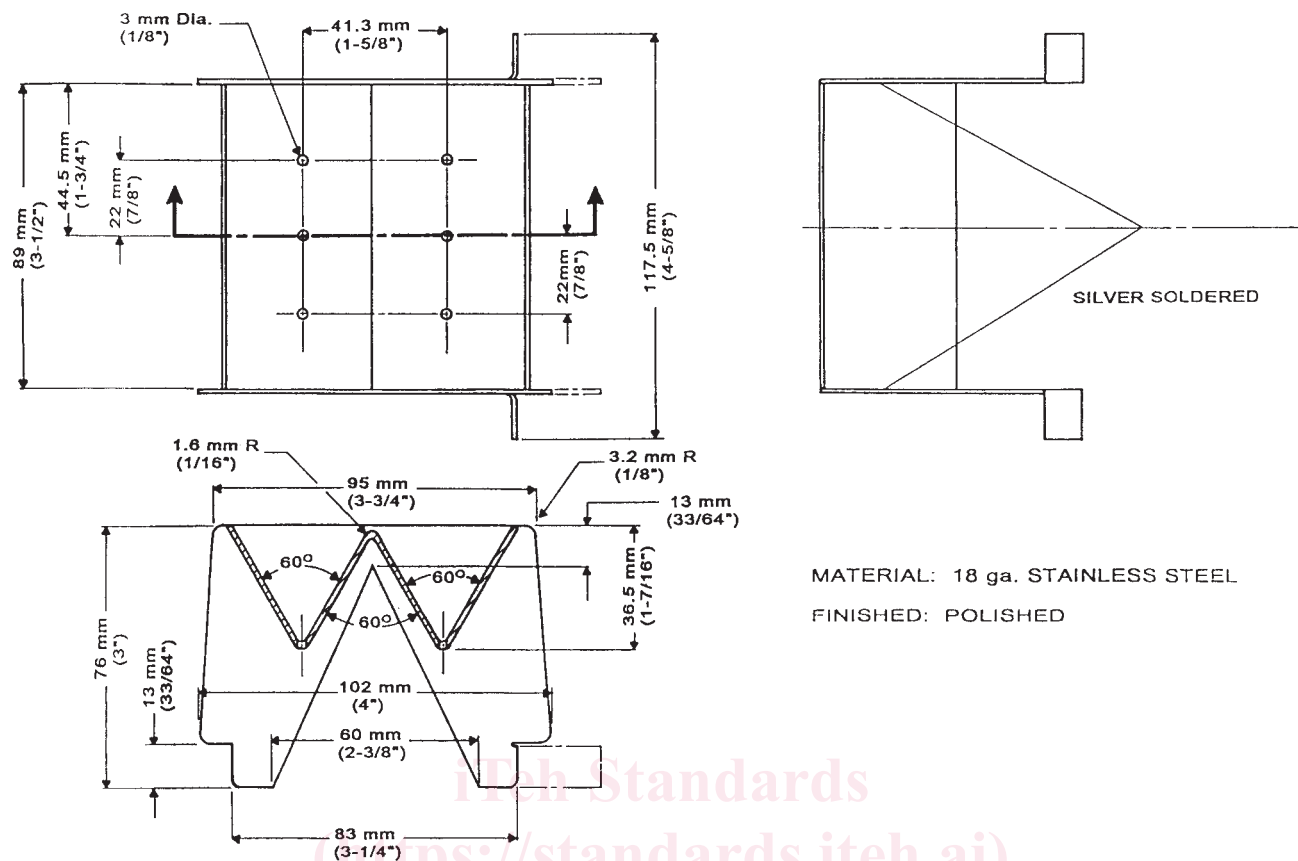

FIG. 1 Distribution Funnel

MATERIAL: 18 ga. STAINLESS STEEL
FINISHED: POLISHED

NOTE 4—The temperature and viscosity of the plasticizer is important (see 4.2 and section 4.3).

11.1.6 With the mixer jacket at 88°C and the mixer and recorder running, remove the cover plate and add the PVC/clay mix to the bowl. Replace bowl cover and continue mixing.

11.1.7 After 4.5 min (or at a stock temperature of 88°C) remove the cover plate and place the prewetted dispersion trough over the bowl.

11.1.8 At 5 min pour the DIDP evenly and quickly into the dispersion trough. Allow the beaker and trough to drain for 1 min. Remove the beaker and trough and replace the cover plate.

11.1.9 Allow the ingredients to mix for at least 2 min beyond the dry point. Turn off the mixer and recorder and clean the bowl.

NOTE 5—The mixer measuring head is best cleaned using a hose and a vacuum cleaner to remove the bulk of the powder from the bowl. The bowl can then be opened, brushed, and blown clean. The walls of the bowl and rotors should be wiped with a clean cloth. A drop of plasticizer placed between each rotor and back plate of the head will lubricate the rotors.

11.1.10 For additional tests, repeat 11.1.4-11.1.9.

11.2 Test Method B (Planetary Mixer):⁵

11.2.1 Attach the Planetary Mixer to the torque rheometer.

11.2.2 If the mixer is oil heated, make connections to the heating unit. Adjust the bowl temperature to 88 ± 1°C.

11.2.3 Wet the dispersion funnel and the 400-mL beaker with plasticizer and drain both for 1 min. Tare the prewetted beaker and weigh 200 g DIDP.

NOTE 6—The temperature and viscosity of the plasticizer is important (see 6.2 and 6.3).

11.2.4 Weigh 400 g PVC resin. Remove the bowl cover and add the PVC resin. Replace the cover.

NOTE 7—If using the computerized torque rheometer, initiate the computer to calibrate the unit. Add the resin at the end of the calibration, and replace the cover and activate the test program.

11.2.5 After mixing 4.5 min, place the prewetted dispersion funnel in the slot on the bowl cover. After 5 min, pour the DIDP plasticizer into the dispersion funnel. Leave the funnel in place until the end of the test.