

---

---

**Cigarettes — Determination of carbon monoxide in sidestream smoke —  
Method using a routine analytical linear smoking machine equipped with a fishtail chimney**

*Cigarettes — Détermination du monoxyde de carbone dans le courant secondaire de fumée — Méthode utilisant une machine à fumer analytique de routine linéaire équipée d'une cheminée individuelle en forme de queue de poisson*

ISO 20774:2007

<https://standards.iteh.ai/catalog/standards/sist/fee8a136-a82e-4ff6-9df6-3c2ab746becf/iso-20774-2007>



**PDF disclaimer**

This PDF file may contain embedded typefaces. In accordance with Adobe's licensing policy, this file may be printed or viewed but shall not be edited unless the typefaces which are embedded are licensed to and installed on the computer performing the editing. In downloading this file, parties accept therein the responsibility of not infringing Adobe's licensing policy. The ISO Central Secretariat accepts no liability in this area.

Adobe is a trademark of Adobe Systems Incorporated.

Details of the software products used to create this PDF file can be found in the General Info relative to the file; the PDF-creation parameters were optimized for printing. Every care has been taken to ensure that the file is suitable for use by ISO member bodies. In the unlikely event that a problem relating to it is found, please inform the Central Secretariat at the address given below.

**iTeh STANDARD PREVIEW**  
**(standards.iteh.ai)**

ISO 20774:2007

<https://standards.iteh.ai/catalog/standards/sist/fee8a136-a82e-4ff6-9df6-3c2ab746becf/iso-20774-2007>



**COPYRIGHT PROTECTED DOCUMENT**

© ISO 2007

All rights reserved. Unless otherwise specified, no part of this publication may be reproduced or utilized in any form or by any means, electronic or mechanical, including photocopying and microfilm, without permission in writing from either ISO at the address below or ISO's member body in the country of the requester.

ISO copyright office  
Case postale 56 • CH-1211 Geneva 20  
Tel. + 41 22 749 01 11  
Fax + 41 22 749 09 47  
E-mail [copyright@iso.org](mailto:copyright@iso.org)  
Web [www.iso.org](http://www.iso.org)

Published in Switzerland

## Contents

Page

Foreword.....	iv
Introduction .....	v
1 Scope .....	1
2 Normative references .....	1
3 Terms and definitions.....	2
4 Principle .....	2
5 Apparatus .....	3
6 Reagents .....	6
6.1 Standard gas mixtures .....	6
7 Sampling and preparation of cigarettes .....	6
7.1 General.....	6
7.2 Symbols .....	6
7.3 Preparation of the cigarettes for smoking .....	6
7.4 Selection of test portions of cigarettes .....	7
7.5 Marking the butt length .....	7
7.6 Selection of cigarettes.....	8
7.7 Conditioning.....	8
7.8 Preliminary tests before smoking.....	8
8 Preparation for the smoking run .....	9
8.1 Smoking plan .....	9
8.2 Preparation of mainstream and sidestream smoke traps and cigarette holders.....	9
8.3 Setting up the smoking machine .....	9
8.4 Assembly of fishtail chimney and sidestream trap.....	9
9 Procedure for smoking run and collection of sidestream smoke .....	10
9.1 Preparation of fishtail chimney .....	10
9.2 Setting the fishtail chimney flow rate .....	10
9.3 Connection of sidestream glass-fibre pad holders.....	10
9.4 Record the atmospheric conditions .....	10
9.5 Loading the cigarettes.....	10
9.6 Smoking the cigarettes .....	11
10 Determination of carbon monoxide .....	11
10.1 General principles.....	11
10.2 Calculation of carbon monoxide on an on-line (continuous flow) data acquisition system.....	12
10.3 Calculation of CO yields using an off-line (bag collection) system .....	13
11 Summary of other test sample calculations .....	13
12 Test report .....	14
12.1 General.....	14
12.2 Characteristic data about the cigarette .....	15
12.3 Data about sampling.....	15
12.4 Description of test .....	15
12.5 Test results .....	16
13 Repeatability and reproducibility .....	16
Annex A (informative) Smoking plans.....	18
Annex B (informative) Alternative procedure for CO calibration .....	22

## Foreword

ISO (the International Organization for Standardization) is a worldwide federation of national standards bodies (ISO member bodies). The work of preparing International Standards is normally carried out through ISO technical committees. Each member body interested in a subject for which a technical committee has been established has the right to be represented on that committee. International organizations, governmental and non-governmental, in liaison with ISO, also take part in the work. ISO collaborates closely with the International Electrotechnical Commission (IEC) on all matters of electrotechnical standardization.

International Standards are drafted in accordance with the rules given in the ISO/IEC Directives, Part 2.

The main task of technical committees is to prepare International Standards. Draft International Standards adopted by the technical committees are circulated to the member bodies for voting. Publication as an International Standard requires approval by at least 75 % of the member bodies casting a vote.

Attention is drawn to the possibility that some of the elements of this document may be the subject of patent rights. ISO shall not be held responsible for identifying any or all such patent rights.

ISO 20774 was prepared by Technical Committee ISO/TC 126, *Tobacco and tobacco products*.

## iTeh STANDARD PREVIEW (standards.iteh.ai)

[ISO 20774:2007](https://standards.iteh.ai/catalog/standards/sist/fee8a136-a82e-4ff6-9df6-3c2ab746becf/iso-20774-2007)

<https://standards.iteh.ai/catalog/standards/sist/fee8a136-a82e-4ff6-9df6-3c2ab746becf/iso-20774-2007>

## Introduction

Cigarettes are manufactured to close tolerances using strict quality control procedures.

However, all the constituents involved in the manufacture are derived from natural products and this results in a final product which is intrinsically variable. Further complexity arises as the cigarette is combusted during smoking to yield the cigarette smoke.

The quantitative measurement of carbon monoxide is therefore dependent on the arbitrary definition of the means used to generate and collect the smoke. In particular, the ambient conditions (e.g. temperature, humidity, air movement within the laboratory) under which the test pieces are conditioned and smoke is collected, play a critical role in the accuracy of the measurement.

Sidestream smoke in this International Standard is understood to be the smoke that is evolved from the cigarette during the smoking run other than from the mouth end.

**NOTE** This is distinguished from environmental tobacco smoke (ETS), which is a mixture of aged and diluted exhaled mainstream smoke and aged and diluted sidestream smoke, and for the assessment of which the present method does not apply.

From the time that scientists have attempted to determine carbon monoxide yields in sidestream smoke, many different methods have been adopted. However, experience has shown some procedures to be more reliable and more amenable to handling of large numbers of samples. With these factors in mind, during the 1999–2002 period, collaborative studies by a task force composed of CORESTA members have shown that improvements in repeatability and reproducibility result when some restrictions are placed upon the wide variety of methods and practices described in existing methods.

<https://standards.iteh.ai/catalog/standards/sist/fee8a136-a82e-4ff6-9df6-3a7777777777>

This International Standard, produced after much collaborative experimentation by many laboratories in many countries, reflects the results of the optimization proposed and validated by the task force and provides one set of procedures that are the accepted reference procedures and for which repeatability and reproducibility of the determinations were assessed. Experience in the task force has shown how strict adherence to the detailed set up and conditions of the method, as well as the degree of proficiency of the operator, affect the precision of the results.

Further, it is preferable that the selected method be compatible with different modes of cigarette equilibration or puffing parameters for the smoking of the tested pieces. The standards defined by ISO for the determination of mainstream yields were, however, followed to the largest possible extent, although the machines used by the different laboratories were all of a linear type.

This method is a machine method and it allows cigarettes to be smoked using a strictly controlled set of parameters. Thus it enables the sidestream carbon monoxide yields from cigarettes, when smoked by this procedure, to be compared and ranked. In the course of its studies, the task force demonstrated the value of comparing the analytical processes and their stability by use of the CORESTA monitor test piece for determining sidestream CO yields.

Since the determination of sidestream CO yield is by nature more complex and delicate than its counterpart performed on mainstream smoke, it is highly recommended to include a control test piece in the smoking plans, as is done in mainstream determinations. It is possible to use the CORESTA monitor or any other internally designed control cigarette for this purpose. The use of an internationally recognized monitor test piece is recommended.

**iTeh STANDARD PREVIEW**  
**(standards.iteh.ai)**

ISO 20774:2007

<https://standards.iteh.ai/catalog/standards/sist/fee8a136-a82e-4ff6-9df6-3c2ab746becf/iso-20774-2007>

# Cigarettes — Determination of carbon monoxide in sidestream smoke — Method using a routine analytical linear smoking machine equipped with a fishtail chimney

## 1 Scope

This International Standard is applicable to the determination of carbon monoxide present in the sidestream smoke from cigarettes. The described method is specified using the ISO 3308 smoking parameters (puff volume, duration and frequency) and butt length, but it is technically compatible with other smoking regimes.

NOTE The method may not be directly applicable to other sidestream smoke analytes.

## 2 Normative references

The following referenced documents are indispensable for the application of this document. For dated references, only the edition cited applies. For undated references, the latest edition of the referenced document (including any amendments) applies.

ISO 2971, *Cigarettes and filter rods — Determination of nominal diameter — Method using a laser beam measuring apparatus*

ISO 20774:2007

<https://standards.iteh.ai/catalog/standards/sist/fee8a136-a82e-4ff6-9df6->

ISO 3308, *Routine analytical cigarette-smoking machine — Definitions and standard conditions*

ISO 3402, *Tobacco and tobacco products — Atmosphere for conditioning and testing*

ISO 4387, *Cigarettes — Determination of total and nicotine-free dry particulate matter using a routine analytical smoking machine*

ISO 6488, *Tobacco and tobacco products — Determination of water content — Karl Fischer method*

ISO 6565, *Tobacco and tobacco products — Draw resistance of cigarettes and pressure drop of filter rods — Standard conditions and measurement*

ISO 8243, *Cigarettes — Sampling*

ISO 8454:1995, *Cigarettes — Determination of carbon monoxide in the vapour phase of cigarette smoke — NDIR method*

### 3 Terms and definitions

For the purposes of this document, the following terms and definitions apply.

- 3.1 sidestream vapour phase**  
portion of the sidestream smoke which passes through a Cambridge filter pad under the conditions specified in the method
- 3.2 smoking process**  
use of a smoking machine to smoke cigarettes from lighting to final puff
- 3.3 smoking run**  
specific smoking process to produce such sidestream smoke from a sample of cigarettes as is necessary for the determination of the smoke components
- 3.4 laboratory sample**  
sample intended for laboratory inspection or testing and which is representative of the gross sample or the sub-period sample
- 3.5 conditioning sample**  
cigarettes selected from the test sample for conditioning prior to tests for sidestream carbon monoxide yield
- 3.6 test sample**  
cigarettes for test taken at random from the laboratory sample and which are representative of each of the increments making up the laboratory sample
- 3.7 test portion**  
group of cigarettes prepared for a single determination and which is a random sample from the test sample or conditioned sample, as appropriate
- 3.8 conditioned sample**  
conditioned cigarettes smoked for sidestream carbon monoxide tests

### 4 Principle

- Sampling of the test cigarettes.
- Conditioning of the test cigarettes.
- Smoking of the test cigarettes on a smoking machine in accordance with ISO 3308, with the exception of the specifications on air velocity control, and equipped with a fishtail chimney and a glass-fibre filter pad for sidestream smoke collection from each channel.
- Collection of sidestream smoke vapour phase and determination of its carbon monoxide content.

NOTE The determination of the carbon monoxide content can be done either by an on-line measurement or by off-line measurement. In the latter method, the vapour phase, or a proportion of it, is first collected in a gas bag.



## 5 Apparatus

Usual laboratory apparatus and in particular the following items.

5.1 **Fishtail chimney**<sup>1)</sup>, manufactured in glass, of design and dimensions shown in Figure 1.

Dimensions in millimetres

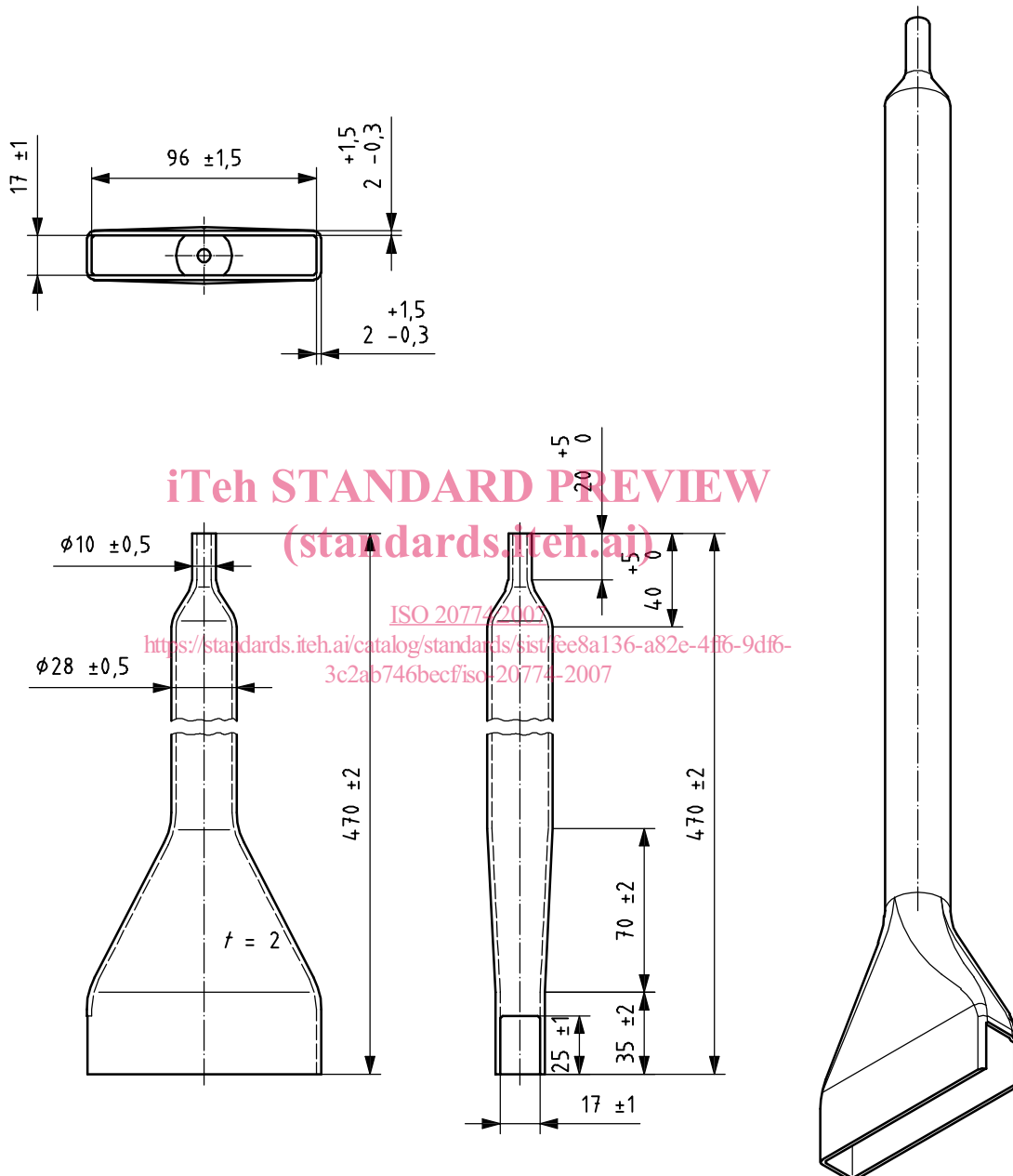
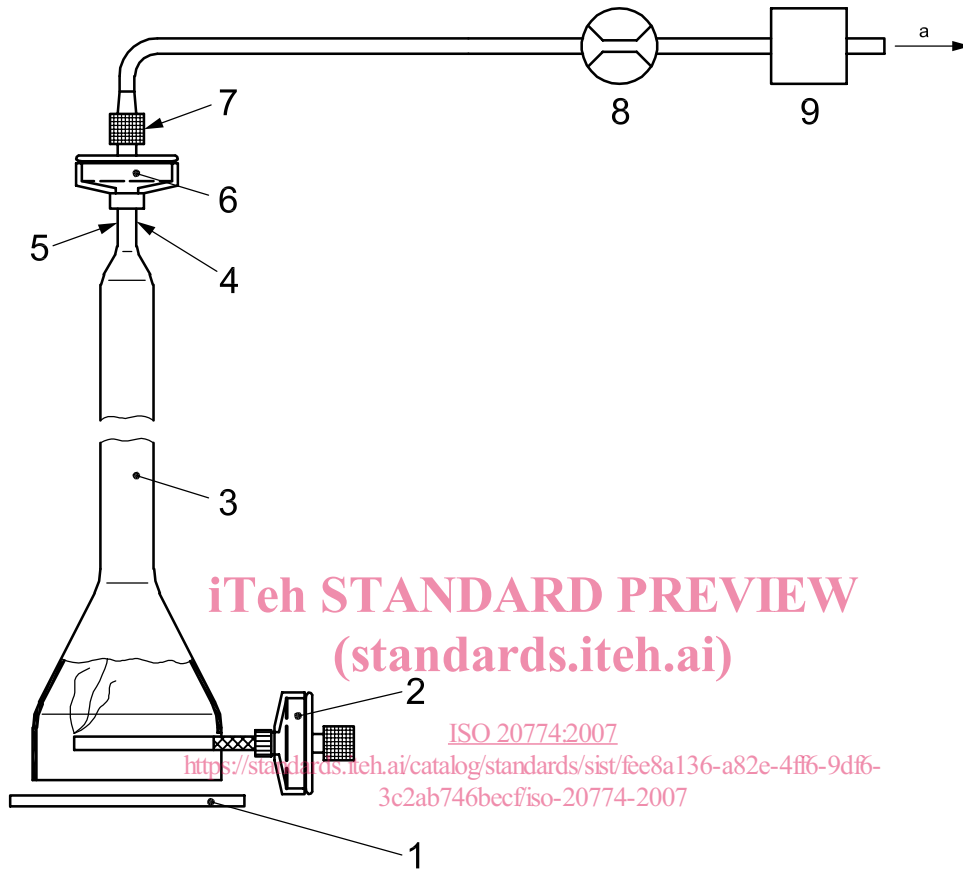

Figure 1 — Fishtail chimney dimensions

1) These fishtail chimneys are commercially available and may be obtained from Borgwaldt Technik GmbH and Cerulean. This information is given for the convenience of users of this International Standard and does not constitute an endorsement by ISO of the product named. Equivalent products may be used if they can be shown to lead to the same results.

**5.2 Routine analytical cigarette-smoking machine**, modified to accept fishtail chimneys and complying with the requirements of ISO 3308 with the exception of the specifications on air velocity control. A plate shall be fixed underneath each channel, with a minimum length of 120 mm and a minimum width of 50 mm. This plate is positioned so as to cover the totality of the opening at the fishtail chimney bottom, as shown in Figure 2.



**Key**

- 1 horizontal plate
- 2 mainstream smoke trap and cigarette holder
- 3 fishtail chimney
- 4 location of calibration flow measurement
- 5 pressure and vacuum tubing
- 6 sidestream smoke trap
- 7 quick connect
- 8 flow meter
- 9 flow regulator

<sup>a</sup> To vacuum pump and CO collection/detector.

**Figure 2 — Sidestream smoke collection system**

**5.3 Non-dispersive infrared (NDIR) analyser**, selective and calibrated for the measurement of CO in vapours and gases.

Analysers are available from several manufacturers and should have a preferred working range of a volume fraction of 0 % to 2 % with a linear output. The analyser should have a precision of 1 % of full scale, a linearity of 1 % of full scale, and a repeatability of 0,2 % of full scale, under conditions of constant temperature and pressure. Its response to a volume fraction of 10 % of CO<sub>2</sub> should not exceed a volume fraction of 0,05 % as CO. Its response to a volume fraction of 2 % of water vapour should not exceed a volume fraction of 0,02 % as CO.

**5.4 Gas sampling bags**, needed only if vapour phase collection is done in bags rather than by a continuous flow system.

When a bag is used as the gas-collecting device, it should be large enough to avoid the final pressure of its contents exceeding the ambient atmospheric pressure. The volume of the bag shall also be no greater than twice the volume of the gas content collected at atmospheric pressure.

Collection bag material shall be suitable for CO and also for CO<sub>2</sub> if it is intended to determine the latter. Tedlar bags are suitable for CO analysis, but will allow CO<sub>2</sub> to gradually leak out upon storage, so that their use would mandate an immediate quantification of the latter. Saran has been shown to be an effective material for the sampling of both gases.

**5.5 Vacuum pump or pumps and flow control devices**, capable of maintaining an air flow of 3 l/min through each fishtail chimney and collection train.

**5.6 PVC tubing**, tubing of approximately 8 mm inside diameter, 11 mm outside diameter, to connect the sidestream trap, in-line flow meter, flow regulator, vacuum pump, gas sampling bag (if used) and CO analyser.

**5.7 Timer**, stopwatch, clock or timing device capable of measuring the elapsed time in seconds.

**5.8 Flow monitoring and regulating system on each channel**, comprising an in-line continuous-reading flow meter, capable of monitoring the flow with a resolution of 0,2 l/min, followed by a precision flow-regulating device.

**5.9 Primary flow meter**, capable of accurately measuring a flow-rate of 3 l/min to a precision of 0,1 l/min, to be used in setting the air flow in each fishtail chimney before a smoke run. As this is a primary measurement, the flow meter should measure the time needed to flush a known volume.

**5.10 Soap bubble flow meter or alternative displacement flow meter**, capable of measuring a displaced volume of at least the desired puff volume, with an accuracy of  $\pm 0,2 \text{ cm}^3$  and a resolution of  $0,1 \text{ cm}^3$ .

**5.11 Apparatus for the determination of puff duration and frequency.**

**5.12 Analytical balance**, with a resolution of 0,1 mg.

**5.13 Draw resistance testing equipment**, as specified in ISO 6565.

**5.14 Conditioning enclosure**, carefully maintained in accordance with the conditions specified in ISO 3402.

**5.15 Length-measuring device**, suitable for measuring to the nearest 0,5 mm.

**5.16 Apparatus for the determination of diameter**, in accordance with ISO 2971.

**5.17 Barometer**, capable of measuring atmospheric pressures to the nearest 0,1 kPa.

## 6 Reagents

Use only reagents of recognised analytical reagent grade.

### 6.1 Standard gas mixtures

Nominally: 0,20 % CO in nitrogen

Nominally: 0,75 % CO in nitrogen

Gas standards with actual values within 25 % of the above are acceptable.

Other gas standards may be used, when alternative calibration procedures are adopted.

The precision of the concentration of gas standard mixture should be 3 % relative or better.

NOTE If CO<sub>2</sub> is also to be determined, it is recommended that nominally: 0,70 % CO<sub>2</sub>, and nominally: 2,00 % CO<sub>2</sub> standard gas mixes be used. In this case calibration gases may be a mixture of CO and CO<sub>2</sub>, with concentrations as described above. Laboratory grade nitrogen or synthetic air is to be used for zeroing the analysers.

## 7 Sampling and preparation of cigarettes

### 7.1 General

Provide a laboratory sample (see 3.4), by using a suitable sampling scheme. Guidance may be found in ISO 8243. The sample will normally contain cigarettes taken from different parts of the population. Make up the test sample required for the test by randomly selecting cigarettes from the different parts of the population represented in the laboratory sample.

iTech STANDARD PREVIEW  
(standards.iteh.ai)  
ISO 20774:2007  
<https://standards.iteh.ai/catalog/standards/sist/fee8a136-a82e-4ff6-9df6-3c2ab746becf/iso-20774-2007>

### 7.2 Symbols

In 7.3, 7.4 and 8.1, the symbols listed in Table 1 are used.

**Table 1 — Symbols used**

Symbol	Variable
<i>N</i>	Number of cigarettes of a given type to be smoked, resulting from sampling at one point in time or from a sub-period sample.
<i>C</i>	Multiplying factor, value greater than 1, to allow for loss due to damage or selection procedures between initial sampling and smoking.
<i>n</i>	Number of replicate determinations of total sidestream particulate matter.
<i>q</i>	Number of cigarettes smoked into the same sidestream trap.
<i>P</i>	Total number of packets of cigarettes available.
<i>Q</i>	Total number of cigarettes available (laboratory sample, see 3.4).

### 7.3 Preparation of the cigarettes for smoking

If *N* cigarettes of a given type are to be smoked, *C* × *N* cigarettes should be prepared from *Q* for conditioning and butt marking. The multiplier *C* is usually at least 1,2 to provide extra cigarettes in case some are damaged. If selection by mass or draw resistance (or any other parameter) is necessary, *C* will have to be much larger (experience suggests 2,0 to 4,0) depending on the selection process.

NOTE The precision data given in this method are based on eight replicates of three cigarettes. Any reduction in the number of replicates will affect the precision. It is not recommended to smoke less than five replicates.