

---

---

**Elastomeric parts for parenterals and for  
devices for pharmaceutical use —**

**Part 2:  
Identification and characterization**

**AMENDMENT 1**

**iTeh STANDARD PREVIEW**

*Éléments en élastomère pour administration parentérale et dispositifs à  
usage pharmaceutique —*

*Partie 2: Identification et caractérisation*

<https://standards.iteh.ai/catalog/standards/08d793a3-67f9-4221-b8d5-625ae4785e7/iso-8871-2-2003-amd-1-2005>  
**AMENDEMENT 1**



**PDF disclaimer**

This PDF file may contain embedded typefaces. In accordance with Adobe's licensing policy, this file may be printed or viewed but shall not be edited unless the typefaces which are embedded are licensed to and installed on the computer performing the editing. In downloading this file, parties accept therein the responsibility of not infringing Adobe's licensing policy. The ISO Central Secretariat accepts no liability in this area.

Adobe is a trademark of Adobe Systems Incorporated.

Details of the software products used to create this PDF file can be found in the General Info relative to the file; the PDF-creation parameters were optimized for printing. Every care has been taken to ensure that the file is suitable for use by ISO member bodies. In the unlikely event that a problem relating to it is found, please inform the Central Secretariat at the address given below.

**iTeh STANDARD PREVIEW**  
**(standards.iteh.ai)**

[ISO 8871-2:2003/Amd 1:2005](https://standards.iteh.ai/catalog/standards/sist/08d793a3-67f9-4221-b8d5-625ae4785e7/iso-8871-2-2003-amd-1-2005)

<https://standards.iteh.ai/catalog/standards/sist/08d793a3-67f9-4221-b8d5-625ae4785e7/iso-8871-2-2003-amd-1-2005>

© ISO 2005

All rights reserved. Unless otherwise specified, no part of this publication may be reproduced or utilized in any form or by any means, electronic or mechanical, including photocopying and microfilm, without permission in writing from either ISO at the address below or ISO's member body in the country of the requester.

ISO copyright office  
Case postale 56 • CH-1211 Geneva 20  
Tel. + 41 22 749 01 11  
Fax + 41 22 749 09 47  
E-mail [copyright@iso.org](mailto:copyright@iso.org)  
Web [www.iso.org](http://www.iso.org)

Published in Switzerland

## Foreword

ISO (the International Organization for Standardization) is a worldwide federation of national standards bodies (ISO member bodies). The work of preparing International Standards is normally carried out through ISO technical committees. Each member body interested in a subject for which a technical committee has been established has the right to be represented on that committee. International organizations, governmental and non-governmental, in liaison with ISO, also take part in the work. ISO collaborates closely with the International Electrotechnical Commission (IEC) on all matters of electrotechnical standardization.

International Standards are drafted in accordance with the rules given in the ISO/IEC Directives, Part 2.

The main task of technical committees is to prepare International Standards. Draft International Standards adopted by the technical committees are circulated to the member bodies for voting. Publication as an International Standard requires approval by at least 75 % of the member bodies casting a vote.

Attention is drawn to the possibility that some of the elements of this document may be the subject of patent rights. ISO shall not be held responsible for identifying any or all such patent rights.

Amendment 1 to ISO 8871-2:2003 was prepared by Technical Committee ISO/TC 76, *Transfusion, infusion and injection equipment for medical and pharmaceutical use*.

This amendment specifies an additional infrared (IR) spectroscopy method coupled with an attenuated total reflection device for the characterization of rubber material by obtaining a fingerprint IR spectrum.

ISO 8871 consist of the following parts, under the general title *Elastomeric parts for parenterals and for devices for pharmaceutical use*:

- *Part 1: Extractables in aqueous autoclavates*
- *Part 2: Identification and characterization*
- *Part 3: Determination of released-particle count*
- *Part 4: Biological requirements and test methods*
- *Part 5: Functional requirements and testing*

**iTeh STANDARD PREVIEW**  
**(standards.iteh.ai)**

[ISO 8871-2:2003/Amd 1:2005](https://standards.iteh.ai/catalog/standards/sist/08d793a3-67f9-4221-b8d5-625ae4785e7/iso-8871-2-2003-amd-1-2005)

<https://standards.iteh.ai/catalog/standards/sist/08d793a3-67f9-4221-b8d5-625ae4785e7/iso-8871-2-2003-amd-1-2005>

# Elastomeric parts for parenterals and for devices for pharmaceutical use —

## Part 2: Identification and characterization

### AMENDMENT 1

*page iii, Contents*

Add the following item to the list after Annex G:

**Annex H (informative) Determination of a fingerprint by surface infrared spectroscopy (ATR, attenuated total reflection)**

**iTeh STANDARD PREVIEW**  
**(standards.iteh.ai)**

*page 2, Subclause 3.5*

[ISO 8871-2:2003/Amd 1:2005](https://standards.iteh.ai/catalog/standards/sist/08d793a3-67f9-4221-b8d5-625ae4785e7/iso-8871-2-2003-amd-1-2005)

Replace 3.5 by the following.

### **3.5 Infrared spectrum**

A very simple method to create a fingerprint of a rubber material is to record an infrared (IR) spectrum. The two common methods for obtaining an IR spectrum of a rubber material are pyrolysis IR and surface IR/ATR (attenuated total reflectance)-technique.

The pyrolysis IR can be obtained as described in Annex A. The surface IR/ATR can be obtained as described in Annex H. The spectra should be compared to a spectrum obtained by the same IR-method on a reference sample of the material.

In practice, pyrolysis IR requires a time-consuming sample preparation and in addition needs the cautious handling of hazardous vapours and oils.

In contrast to this, the surface IR/ATR offers the possibility to obtain a fingerprint from an elastomeric part with minimum or no sample preparation.

Add a new Annex H as follows:

**Annex H**  
(informative)

**Determination of a fingerprint by surface infrared spectroscopy  
(ATR, attenuated total reflection)**

**H.1 General**

The principle of ATR measurement is shown in Figure H.1<sup>1)</sup>.

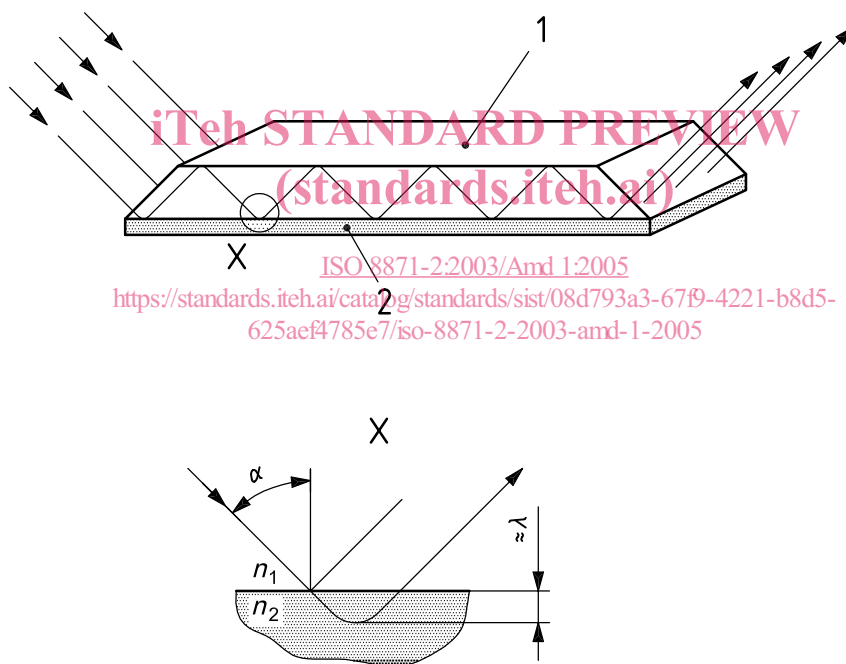

**Key**

- $\alpha$  angle of incident light
- $\lambda$  wavelength of the radiation used
- $n$  refractive index of crystal ( $n_1$ ) and test specimen ( $n_2$ )
- 1 ATR-crystal
- 2 rubber material (test specimen)

**Figure H.1 — Test specimen at the ATR-crystal and pathway of IR-beam**

1) For more information refer to relevant literature or ISO surface infrared measurements.

## H.2 Apparatus

**H.2.1 Fourier transform infrared spectrometer** (FTIR-spectrometer).

**H.2.2 ATR-device.**

## H.3 Preparation of samples

**H.3.1** For sample preparation, provide flat contact surfaces.

**H.3.2** Cut the elastomeric part along an appropriate axis and take the cut edge as surface for measuring.

**NOTE** This provides an elastomeric spectrum without the influence of coatings. Also bands from silicone oil that is often applied to the surface of elastomeric closures, in this way will not disturb the spectrum of the elastomeric material.

## H.4 Procedure

### H.4.1 General

Conventional ATR is only appropriate for elastomeric parts, which have extended flat surfaces to be in contact with the ATR crystal.

Single bounce ATR is necessary if only small surfaces are available to be in contact with the ATR-crystal. Low contact areas give better results for strongly absorbing rubber samples (e.g. high filler content, carbon black as filler).

ATR equipment for an IR microscope provides also access to very small flat contact areas.

The refractive index of the crystal material determines among others (e.g. angle of incident light, wavelength) the depth of the penetration of the IR-light into the substrate.

The crystal material is chosen to be dependent on the absorbance characteristics of the analyte. In the case of highly absorbing elastomeric materials (e.g. carbon black filled formulations) a lower depth of penetration and/or a small contact area provide appropriate spectra.

### H.4.2 Examination of the samples by ATR

Put the flat surface(s) of the elastomeric part(s) on the ATR crystal. Apply a constant (reproducible) pressure to get close contact.

Measure a spectrum from  $700\text{ cm}^{-1}$  to  $3\ 800\text{ cm}^{-1}$ .

## H.5 Expression of results

**H.5.1** The result is a spectrum in transmission mode (% transmission) obtained as surface IR from wave-number  $700\text{ cm}^{-1}$  to  $3\ 800\text{ cm}^{-1}$ . The range of spectrum may be slightly shifted depending on the crystal-material chosen. It can be compared to a reference spectrum with respect to the characteristic wave numbers.

**H.5.2** Report the experimental conditions such as resolution, number of scans and bench purging.

**iTeh STANDARD PREVIEW**  
**(standards.iteh.ai)**

[ISO 8871-2:2003/Amd 1:2005](https://standards.iteh.ai/catalog/standards/sist/08d793a3-67f9-4221-b8d5-625ae4785e7/iso-8871-2-2003-amd-1-2005)

<https://standards.iteh.ai/catalog/standards/sist/08d793a3-67f9-4221-b8d5-625ae4785e7/iso-8871-2-2003-amd-1-2005>

---

---

**ICS 11.040.20**

Price based on 3 pages