



SLOVENSKI STANDARD
SIST-TS CEN/TS 17006:2017
01-april-2017

Zemeljska dela - Kontinuirana kontrola zgoščanja (CCC)

Earthworks - Continuous Compaction Control (CCC)

Erdarbeiten - Kontinuierliche Verdichtungskontrolle

Terrassements - Contrôle du Compactage en Continu (CCC)

Ta slovenski standard je istoveten z: CEN/TS 17006:2016

[SIST-TS CEN/TS 17006:2017](https://standards.iteh.ai/catalog/standards/sist/68b562ac-8c2c-49c1-9f5b-0f07f11408a5/sist-ts-cen-ts-17006-2017)

<https://standards.iteh.ai/catalog/standards/sist/68b562ac-8c2c-49c1-9f5b-0f07f11408a5/sist-ts-cen-ts-17006-2017>

ICS:

93.020	Zemeljska dela. Izkopavanja.	Earthworks. Excavations.
	Gradnja temeljev. Dela pod	Foundation construction.
	zemljo	Underground works

SIST-TS CEN/TS 17006:2017

en,fr,de

iTeh STANDARD PREVIEW
(standards.iteh.ai)

[SIST-TS CEN/TS 17006:2017](https://standards.iteh.ai/catalog/standards/sist/68b562ac-8c2c-49c1-9f5b-0f07f11408a5/sist-ts-cen-ts-17006-2017)

<https://standards.iteh.ai/catalog/standards/sist/68b562ac-8c2c-49c1-9f5b-0f07f11408a5/sist-ts-cen-ts-17006-2017>

TECHNICAL SPECIFICATION
SPÉCIFICATION TECHNIQUE
TECHNISCHE SPEZIFIKATION

CEN/TS 17006

December 2016

ICS 93.020

English Version

Earthworks - Continuous Compaction Control (CCC)

Terrassements - Contrôle du Compactage en Continu
(CCC)

Erdarbeiten - Kontinuierliche Verdichtungskontrolle

This Technical Specification (CEN/TS) was approved by CEN on 5 October 2016 for provisional application.

The period of validity of this CEN/TS is limited initially to three years. After two years the members of CEN will be requested to submit their comments, particularly on the question whether the CEN/TS can be converted into a European Standard.

CEN members are required to announce the existence of this CEN/TS in the same way as for an EN and to make the CEN/TS available promptly at national level in an appropriate form. It is permissible to keep conflicting national standards in force (in parallel to the CEN/TS) until the final decision about the possible conversion of the CEN/TS into an EN is reached.

CEN members are the national standards bodies of Austria, Belgium, Bulgaria, Croatia, Cyprus, Czech Republic, Denmark, Estonia, Finland, Former Yugoslav Republic of Macedonia, France, Germany, Greece, Hungary, Iceland, Ireland, Italy, Latvia, Lithuania, Luxembourg, Malta, Netherlands, Norway, Poland, Portugal, Romania, Slovakia, Slovenia, Spain, Sweden, Switzerland, Turkey and United Kingdom.

(standards.iteh.ai)

[SIST-TS CEN/TS 17006:2017](https://standards.iteh.ai/catalog/standards/sist/68b562ac-8c2c-49c1-9f5b-0f07f11408a5/sist-ts-cen-ts-17006-2017)

<https://standards.iteh.ai/catalog/standards/sist/68b562ac-8c2c-49c1-9f5b-0f07f11408a5/sist-ts-cen-ts-17006-2017>



EUROPEAN COMMITTEE FOR STANDARDIZATION
COMITÉ EUROPÉEN DE NORMALISATION
EUROPÄISCHES KOMITEE FÜR NORMUNG

CEN-CENELEC Management Centre: Avenue Marnix 17, B-1000 Brussels

Contents	Page
European foreword.....	4
1 Scope	5
2 Terms and definitions	5
3 Fundamentals and principles of CCC measurements	7
4 Influences on the CCC measuring value	8
4.1 General.....	8
4.2 Roller	8
4.2.1 General.....	8
4.2.2 Static linear load of roller drum	8
4.2.3 Vibration amplitude.....	8
4.2.4 Vibration frequency	8
4.2.5 Operating speed.....	8
4.2.6 Direction of roller	9
4.3 Measuring depth.....	9
4.4 Soils, granular materials and rockfill materials	9
4.4.1 Type of material and water content.....	9
4.4.2 Evenness and inhomogeneities on the layer surface	10
4.4.3 Resting time of the compacted layer.....	10
5 Preconditions and requirements	10
5.1 Soils, granular materials and rockfill materials	10
5.1.1 Soil type	10
5.1.2 Requirements for the layer surface	10
5.2 Requirements for CCC rollers	10
5.3 CCC Measuring and documentation system.....	11
5.3.1 Structure of the measuring and documentation system.....	11
5.3.2 Requirements for the CCC measuring and documentation system.....	11
5.4 Reproducibility	12
5.5 Personnel requirements.....	12
6 CCC applications	12
7 CCC with calibration for indirect continuous density and stiffness control and QC and QA purpose	12
7.1 General.....	12
7.2 CCC quality control and acceptance testing with calibration.....	13
7.2.1 Procedure.....	13
7.2.2 Control areas / inspection areas	13
7.2.3 Alternative decision rules	14
7.3 Selection of the calibration test area	14
7.4 Calibration procedure	14
7.5 Development of correlations	15
7.5.1 General principles.....	15
7.5.2 Quality and validity of correlation.....	15
7.5.3 Examples of correlations.....	16
8 CCC weak area analysis and documentation for QC and QA purpose	16
8.1 General.....	16
8.2 CCC quality control and acceptance testing for weak area analysis	16

9	CCC – documentation of maximum compaction achievable for QC and QA purpose.....	17
9.1	General	17
9.2	CCC quality control and acceptance testing for documentation of maximum compaction for QA purpose.....	17
10	CCC - documentation of compaction method.....	17
10.1	General	17
10.2	CCC quality control and acceptance testing for method specification.....	18
11	CCC test report	18
Annex A (informative) Analysis of the vibration behaviour		19
A.1	Principle of compaction energy.....	19
A.2	Principle of harmonic wave	20
A.3	Measuring the dynamic stiffness.....	21
Annex B (informative) Statistical evaluation of CCC values based on decision rules for CCC application with calibration		22
B.1	Decision rules – Analysis of the unweighted fall-below areas if normally distributed measuring values exist	22
B.2	Evaluation of the unweighted fall-below areas in case of arbitrary distribution of the measuring values or the total fall-below area ratio.....	24
B.3	Evaluation of the weighted fall-below areas in case of arbitrary distribution of the measuring values or the total fall-below area ratio.....	24

[SIST-TS CEN/TS 17006:2017](https://standards.iteh.ai/catalog/standards/sist/68b562ac-8c2c-49c1-9f5b-0f07f11408a5/sist-ts-cen-ts-17006-2017)
<https://standards.iteh.ai/catalog/standards/sist/68b562ac-8c2c-49c1-9f5b-0f07f11408a5/sist-ts-cen-ts-17006-2017>

CEN/TS 17006:2016 (E)**European foreword**

This document (CEN/TS 17006:2016) has been prepared by Technical Committee CEN/TC 396 "Earthworks", the secretariat of which is held by AFNOR.

Attention is drawn to the possibility that some of the elements of this document may be the subject of patent rights. CEN shall not be held responsible for identifying any or all such patent rights

This Technical Specification was prepared with the aim of having a 3-year lifetime.

According to the CEN/CENELEC Internal Regulations, the national standards organisations of the following countries are bound to announce this Technical Specification: Austria, Belgium, Bulgaria, Croatia, Cyprus, Czech Republic, Denmark, Estonia, Finland, Former Yugoslav Republic of Macedonia, France, Germany, Greece, Hungary, Iceland, Ireland, Italy, Latvia, Lithuania, Luxembourg, Malta, Netherlands, Norway, Poland, Portugal, Romania, Slovakia, Slovenia, Spain, Sweden, Switzerland, Turkey and the United Kingdom.

**iTeh STANDARD PREVIEW
(standards.iteh.ai)**

SIST-TS CEN/TS 17006:2017

<https://standards.iteh.ai/catalog/standards/sist/68b562ac-8c2c-49c1-9f5b-0f07f11408a5/sist-ts-cen-ts-17006-2017>

1 Scope

This technical specification provides guidance, specifications and requirements on the use of Continuous Compaction Control (CCC) as a quality control method in earthworks by means of roller integrated dynamic measuring and documentation systems.

The CCC method is suitable for soils, granular materials and rockfill materials which can be compacted using vibratory rollers.

NOTE A continuous Compaction Control (CCC) technology based on the measure of propel energy necessary to overcome the rolling resistance is also available and can be used as a quality control method in earthworks. The propelling power of the compactor provides an indication of the material stiffness and it is measured as a function of the machine ground speed, slope angle and rolling resistance. This method is not included in this document.

2 Terms and definitions

For the purposes of this document, the following terms and definitions apply.

2.1

vibratory roller

vibratory roller is a roller which generates:

- a) vertical vibrations (circular exciters) with fixed amplitudes; or
- b) horizontal vibrations (oscillation rollers) with fixed amplitudes; or
- c) vibrations with a direction, amplitude and/or frequency that can be automatically or manually adjusted during operations

Note 1 to entry: Vibratory rollers operating with automatic amplitude and/or frequency mode are called 'intelligent rollers'.

SIST-TS CEN/TS 17006:2017
<https://standards.iteh.ai/catalog/standards/sist/68b562ac-8c2c-49c1-9f5b-0f07f11408a5/sist-ts-cen-ts-17006-2017>

2.2

measuring roller

vibratory roller which is equipped with a compaction measuring and documentation system which measures and maps the dynamic properties of the compacted surface

Note 1 to entry: See Figure 1.

2.3

Continuous Compaction Control

CCC

use of measuring rollers for quality control in earthworks

2.4

CCC measuring value

dynamic value which depends on the measuring principle, the type of roller, operating weight, amplitude, frequency and operating speed used, the type of soil or granular or rockfill material and its water content

Note 1 to entry: CCC measuring values determined by different systems are not necessarily equivalent.

2.5

stiffness of a soil

quotient of applied force (loading) and the corresponding deformation

CEN/TS 17006:2016 (E)

2.6

dynamic stiffness of a soil

quotient of variation of dynamic soil reaction force and the corresponding variation of deformation (soil displacement)

2.7

compaction depth

depth below the point at which the drum meets the investigated surface over which the roller provides a significant compaction effect

2.8

measuring depth

depth below the point at which the drum meets the investigated surface over which the resulting response from the underlying materials still has an effect on the CCC measuring value

2.9

CCC inspection area

part of the production that has been processed under uniform conditions for which a unique compaction requirement is valid

2.10

fall-below spot

part of the control areas in which the CCC measuring value falls below a certain CCC target value

2.11

measuring area unit

part of a control area, the width of which equals the drum width of the roller and the length of which corresponds to the product of the operating speed and duration of the individual measurement

iTech STANDARD PREVIEW
(standards.iteh.ai)
<https://standards.iteh.ai/catalog/standards/sist/68b562ac-8c2c-49c1-9f5b-0f07f11408a5/sist-ts-cen-ts-17006-2017>

2.12

jump operation

roller drum that partially loses ground contact, which occurs with increasing soil stiffness

2.13

double jump

jump operation when the drum loses contact during a complete vibration cycle

Note 1 to entry: The roller drum hits the very stiff ground, rebounds and then makes a full cycle in the air before hitting the ground again

Note 2 to entry: When jump operation becomes more pronounced because of high soil stiffness double jump can occur, which usually significantly reduces the magnitude of the CCC measured values. In this way, the CCC measuring system can identify and indicate jumping operation.

2.14

positioning system

system for georeferencing the compaction or measuring roller on the area being processed

2.15

roller pass

one forward or backward operation of a vibratory roller over a certain distance

2.16

weak area

part of CCC control area, which presents lower CCC values than the rest of the control area

3 Fundamentals and principles of CCC measurements

Roller integrated continuous compaction control (CCC) is based on the dynamic interaction between the excited drum of a vibratory roller and the soil or granular or rockfill material that has to be compacted. The dynamically measured value determined from the movement behaviour of the drum shall be physically clearly defined.

Vibratory rollers are characterized by a drum that is excited by one or more eccentric masses rotating at constant speed. CCC rollers are equipped with acceleration transducers, processors and a display to provide a record of the drum to soil interaction (Figure 1).

During the roller pass of a vibratory roller there is a continuous exchange of kinetic energy between the roller drum and the roller/soil vibrating system.

Both the soil stiffness and the absorption of the roller vibration change with increasing compaction. By analysing the vibration behaviour, conclusions can be made about the compaction quality. This analysis can follow various principles. See Annex A.

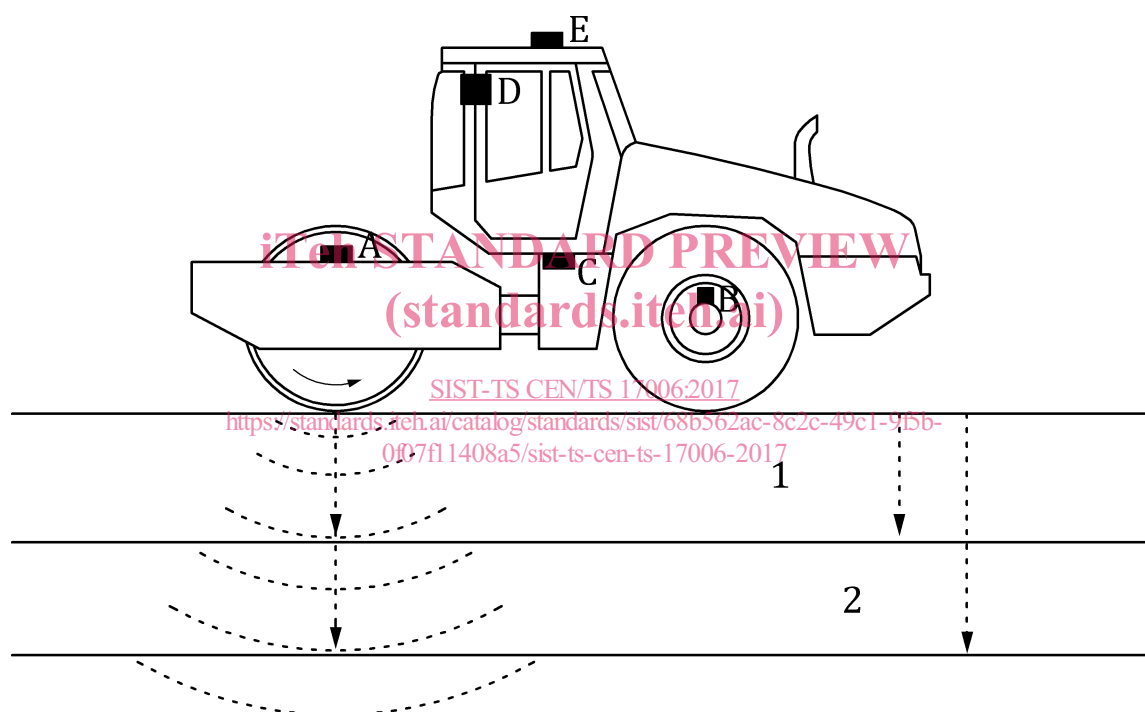

Key

- 1 compaction depth
- 2 measuring depth
- A acceleration transducer
- B distance sensor
- C processor
- D display and recorder
- E positioning systems (GNSS antenna)

Figure 1 — Single drum roller for CCC measurements (schematic diagram)

4 Influences on the CCC measuring value

4.1 General

The CCC measuring values can be used to evaluate the stiffness, the soil compaction process and the compaction quality. For proper interpretation of the CCC measuring values, the major influencing parameters need to be considered. The most important parameters are the weight, amplitude, frequency and operating speed of the roller, driving direction, measuring depth and layer thickness, the type of material, its water content and the evenness of soil surface.

4.2 Roller

4.2.1 General

There are three types of rollers as follows:

- Single drum rollers (vibratory rollers driven by rubber wheels) with a smooth drum, which may also be driven, provide the best results with respect to constant travel speed. Their higher mobility and generally problem-free use on slopes and loose surfaces are also advantageous. It is also possible to use vibrating pad foot rollers for certain materials.
- Tandem vibratory rollers with two smooth drums are usually less suitable. Under some subgrade and adverse terrain conditions (e.g. slopes) these rollers may sometimes suffer from “slip” of the driven drums. The travel speed then sometimes becomes difficult to control.
- “Intelligent” rollers are vibratory rollers which automatically adjust the compaction energy by changing the amplitude and/or frequency during the compaction process. When intelligent rollers are used for CCC, the amplitude and the frequency need to be fixed.

4.2.2 Static linear load of roller drum

<https://standards.iteh.ai/catalog/standards/sist/68b562ac-8c2c-49c1-9f5b-0f07f11408a5/sist-ts-cen-ts-17006-2017>

The static linear load is a roller parameter which is the load of the drum plus the effective frame weight divided by the drum width.

The higher the static linear load, the larger the measuring depth.

NOTE The static linear load influences the motion behaviour of the drum, such that rollers with a light frame have a higher tendency to jump.

4.2.3 Vibration amplitude

The theoretical amplitude of the drum is a roller parameter which is a function of the drum mass, the eccentric mass and its eccentricity.

The magnitude of the amplitude influences the measuring depth and the motion behaviour of the drum and consequently the magnitude and range of the CCC measuring values.

NOTE The measuring depth is higher if the roller is operating with high amplitude. However, this mode of operation increases the risk of grain crushing and re-loosening of soil near the surface; and the drum has a higher tendency to jump than during operation with lower amplitudes.

4.2.4 Vibration frequency

The vibration frequency is a roller parameter which is the number of vibration cycles per second. The frequency affects the magnitude of the CCC values.

4.2.5 Operating speed

The operating speed affects the magnitude of the CCC measuring values. In general for much lower speeds higher measuring values can be expected.

4.2.6 Direction of roller

The operating direction affects the magnitude of the CCC measuring values.

If construction purposes require measuring passes to be performed when the roller is moving both forwards and backwards, then comparative passes with the roller travelling in each direction need to be performed beforehand; these are to check whether the magnitude of the CCC measuring values obtained during backwards passes differs from the values obtained during forward passes.

4.3 Measuring depth

The measuring depth depends particularly on the static linear load of the drum, the vibration amplitude and vibration frequency, the stiffness of the layer to be compacted and the stiffness of the underlying materials.

Under uniform conditions, the measuring depth can be estimated according to Table 1, which shows, as an example, the values that can be achieved by smooth single drum vibrating rollers on gravelly soil placed in layers.

Table 1 — Examples of measuring depth to be expected (gravelly soil, smooth single drum vibrating rollers)

	Operating mass	Static linear load	Low amplitude (0,8 – 1 mm)	High amplitude (1,5 – 2 mm)
Light single drum rollers	< 10 t	15 – 30 kN/m	approx. 0,4 m to 0,6 m	approx. 0,6 m to 1,0 m
Medium weight single drum rollers	10 – 15 t	20 – 40 kN/m	approx. 0,4 m to 0,8 m	approx. 0,6 m to 1,5 m
Heavy single drum rollers	15 – 22 t	40 – 60 kN/m	approx. 0,6 m to 1,2 m	approx. 1,0 m to 2,0 m
Extra-heavy single drum vibratory rollers	> 22 t	60 – 80 kN/m	approx. 0,6 m to 1,2 m	approx. 1,0 m to 2,5 m

Non-uniform soil stiffnesses have a major influence on the measuring depth, so CCC should carefully be used on the bottom layer of an embankment and should only be used from the second layer on upwards when estimation of density is purpose of the measurement.

NOTE The measuring depth is usually greater than compaction depth (See Figure 1).

4.4 Soils, granular materials and rockfill materials

4.4.1 Type of material and water content

The type of soil and particularly the proportion of fine grained materials (<0,063 mm) and the water content influence the magnitude of the CCC measuring value.

For soils and granular materials with up to 15 % < 0,063 mm, good correlations between degree of compaction and CCC measuring value can typically be expected if the water contents are below the optimum water content. In such cases, there is also usually a good correlation between the CCC measuring value and static or dynamic deformation modulus.

For composite soils with more than 15 % < 0,063 mm and fine soils, special attention should be given to the water content. A correlation between CCC measuring value and degree of compaction is only possible under uniform soil and water conditions.

NOTE When satisfactory compaction of composite and fine soils is not possible because the water content of the material to be compacted is too high, a lower CCC measuring value is registered which does not increase but rather decreases as the number of passes increases.